



# Hopper bench



## Design

© Design by Dirk Wynants for Extremis, 2010

## Extremis awards

- Henry Van De Velde Award, 2001
- Hermes Creative Award, 2002
- De Leeuw van de Export Award, 2003
- Design Management Europe Award, 2007
- Unizo KMO Laureaat, 2008
- Green Good Design Award, 2013
- Sustainable Enterprise, POM Vlaanderen, 2016

## Text

In streetscapes and squares, gardens or balconies, Hopper bench suits any location. This multi-functional design can be used in more ways than a traditional city bench. The attached legs allow you to slide in from the sides and sit down with a backrest. And the top surface doubles as a tabletop when facing the opposite direction. The versatility of this design allows for a quick change of scenery while adding comfort along the way.

If you prefer a mono-material bench, you can opt for Hopper bench AA, our All Aluminium version!

- Consists of one tabletop and one seating with a wooden surface.
- Galvanized or powder coated aluminium legs that attach the tabletop to the bench
- Robust, durable materials (suitable for intensive use in public spaces and in a maritime climate)
- 2 different lengths 240 and 300 (3 to 4 people)
- Characteristic curved legs that serve as 2 access zones

- Tabletop and bench made from sustainability category 1 'Iroko' tropical hardwood or thermally treated 'Hellwood' ash with PEFC label.
- Tabletop and bench are fully supported by a galvanized steel frame.
- Legs made from hot dip galvanized steel or powder coated aluminium (in Black RAL9005, Earth, Verdigris, Reed green RAL6013, Off white RAL9002, Beach beige RAL1019 and Copper brown RAL8004 as standard, custom color possible on request)
- Low maintenance
- Suitable for indoors and outdoors
- The legs always come with two anchoring holes  $\varnothing 1,2$  cm
- Optional stabilizing supports
- Weight: from 110 to 127 kg
- Packaging serves as assembly table

More info: <https://www.extremis.com/en/collections/hopper/hopper-bench>

## Construction

### Tabletop:

- Wood
  - Iroko (tropical hardwood)
  - Hellwood (thermally treated wood - standard PEFC label)
- Supporting frame made from hot dip galvanized steel

### One bench:

- Wood
  - Iroko (tropical hardwood)
  - Hellwood (thermally treated wood - standard PEFC label)
- Supporting frame made from hot dip galvanized steel
- 240 cm: max. 5 people or 400 kg per bench
- 300 cm: max. 6 people or 480 kg per bench

### Two legs:

- Hot dip galvanized steel or structured powder coated aluminium
- Powder coated aluminium standard colors: Black RAL9005, Earth, Verdigris, Reed green RAL6013, Off white RAL9002, Beach beige RAL1019 and Copper brown RAL8004. Custom color available on request (RAL colors only).

### Optional set of stabilizing supports:

- Hot dip galvanized steel or structured powder coated aluminium

## Materials info

### Iroko:

- Tropical hardwood, durability class 1
- Chain of Custody
- Thickness of benches and tabletop: 30 mm (+- 2 mm)
- Density of tabletop and benches: 600 to 700 kg/m<sup>3</sup>
- Suitable for indoors and outdoors
- The wood is untreated on delivery; untreated wood turns grey in color over time
- Natural product with a warm appearance

- Very quick drying time after a rain shower
- Feels comfortable in all weather conditions
- If the wood is stained or scratched, this can be removed by lightly sanding the wood. It's recommended to oil the wood annually for easier maintenance and to counteract the greying effect.

## **Hellwood:**

- Hellwood is a European ash that is thermally treated, durability class 1
- PEFC label for sustainable forest management
- Thickness of benches and tabletop: 30 mm (+- 2 mm)
- Density of tabletop and benches: 600 kg/m<sup>3</sup>
- Suitable for indoors and outdoors
- The wood is untreated on delivery; untreated wood turns grey in color over time
- Natural product with a warm appearance
- Very quick drying time after a rain shower
- Feels comfortable in all weather conditions
- If the wood is stained or scratched, this can be removed by lightly sanding the wood. It's recommended to oil the wood annually for easier maintenance and to counteract the greying effect.

## **Hot dip galvanized steel (table + bench frame and legs):**

- Hot dip galvanizing provides a protective layer
- Longlasting
- Low maintenance
- 100% recyclable
- Cradle to Cradle Certified
- Thickness of tabletop and bench: 2-6 mm
- Thickness of legs and back support: 8 mm
- Layer thickness 50-100 microns
- Density: 7.5 10<sup>3</sup>kg/m<sup>3</sup>
- Outdoors and indoors
- Very good UV-resistance, galvanized steel will be less shiny over time
- Flame retarding (NEN-eN13501-1 A1)
- Galva Power C2C certificate

## **Aluminium (legs in textured coating):**

- Eco-design: 10 table legs fit exactly in a standard sheet of metal, no material waste
- Texture coating is sprayed dry on an object that is electrostatically charged.
- More scratch-resistant than non-textured coatings
- Thickness 10 mm
- Layer thickness 50-100 microns
- Density: 2.70 10<sup>3</sup>kg/m<sup>3</sup>
- Outdoors and indoors
- Very good UV fastness
- Flame retarding (NEN-EN13501-1 A2-s1)

All fixing materials are manufactured from stainless steel and are equipped with various security systems, both chemical (loctite, precoat) and mechanical (open retaining rings, corrugated O-rings).





## Dimensions

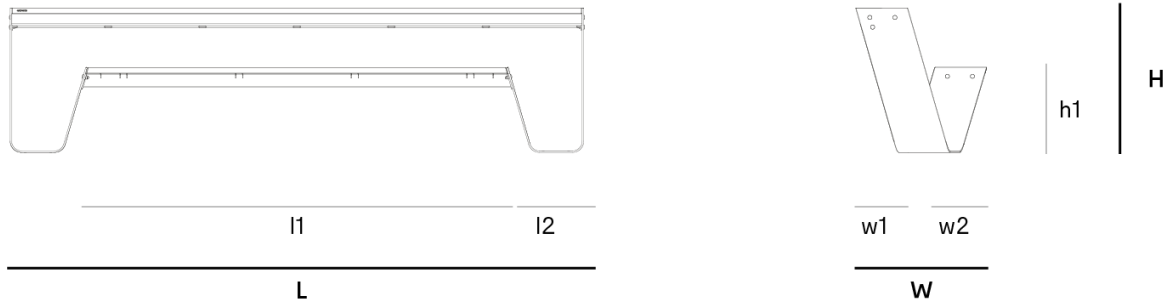

Dimensions (mm)	L	W	H	l <sub>1</sub>	l <sub>2</sub>	w <sub>1</sub>	w <sub>2</sub>	h <sub>1</sub>
Hopper bench 240	2380	680	740	1595	382	278	278	440
Hopper bench 300	2980	680	740	2195	382	278	278	440

## Weight and transport volume

- 240 cm, hot dip galvanized feet: 110,80 kg and 0.66 m<sup>3</sup>
- 240 cm, aluminium powder coated feet: 82,40 kg and 0.66 m<sup>3</sup>
- 300 cm, hot dip galvanized legs: 116,80 kg and 0,72 m<sup>3</sup>
- 300 cm, aluminium powder coated legs: ? kg and 0,72 m<sup>3</sup>

View more details on the technical factsheet at <https://www.extremis.com/en/product-downloads/hopper-bench>

## Standards

- NEN-EN13501-1 A (Inox and galvanized steel, flame retarding)
- ISO 105-B02 (Sunbrella) (UV resistance)

## Certificates

- PEFC
- Cradle to Cradle

## Guarantee

The entire Extremis collection has a 2-year guarantee, based on the provisions in our general guarantee terms & conditions.

## Maintenance

### Wood

- Little maintenance required, but the better it is treated, the longer it will last.
- Regularly/after use: wet cloth.
- To remove stubborn dirt residues use a hard brush and water.

- Once to twice per year: clean thoroughly. We recommend that this is done in the spring and just before winter.
- Oil before the first use and once per year. An oiled table will absorb liquids less quickly and therefore remains clean for longer.
- Every 2 to 4 years: sand the wood with a sander and sandpaper with grain 120. After a few years, the wood will display cracks and can become slightly misshapen. This is perfectly normal as wood is a natural and living material. The great advantage of solid wood is that you can sand down the top surface to make the surface even and smooth once more. Use a hand sander for this (do it on a dry day).
- Any cracks can be hand sanded. Use 120-grain sandpaper for this. Be careful not to permanently damage the fibres. It is for this reason that a high-pressure washer should never be used to clean wood.

### **Frame/legs:**

Regular cleaning with lukewarm water and mild cleaning product. Use a soft brush to remove any caked-on dirt.

More info: <https://www.extremis.com/maintenance>

### **Applications**

- Indoor
- Outdoor
- Residential
- Businesses
- Hospitality
- Educational institutions
- Healthcare
- Public spaces

### **Assembly**

Integrated packaging design reduces assembly time and the packaging for the legs can serve as an assembly table. For more info please see manual:

<https://www.extremis.com/en/product-downloads/hopper-bench>