

# Hopper

picnic

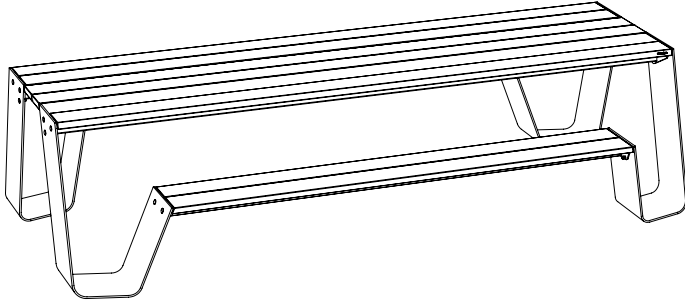

combo

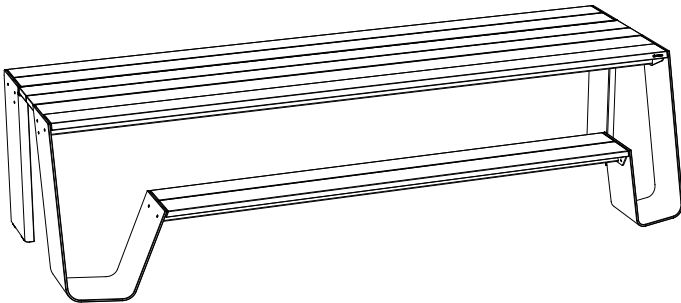

**extremis®**



**IMPORTANT! RETAIN FOR FUTURE  
REFERENCE: READ CAREFULLY.**

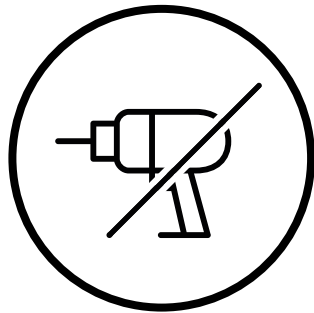
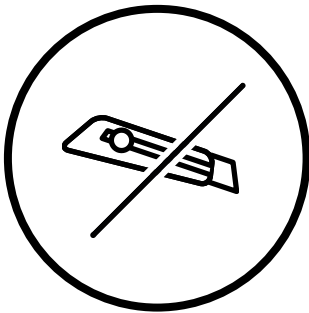

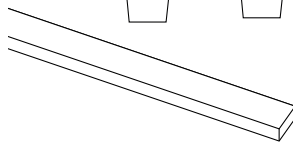
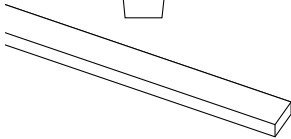
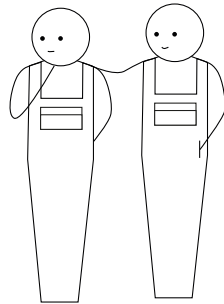
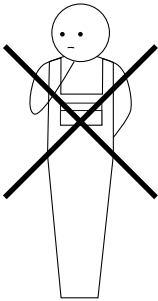
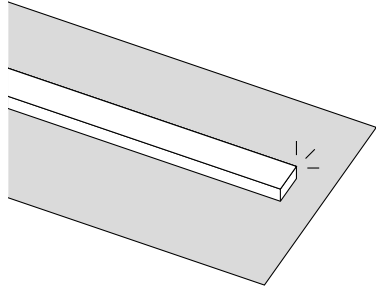

# Table of contents <sup>1/2</sup>

**Mounting kit <sup>↗</sup>**

---

**Exploded view <sup>↗</sup>**

---

**Assembly Hopper picnic <sup>↗</sup>**

---

**Assembly Hopper combo <sup>↗</sup>**

**This is an interactive PDF**

You can easily navigate through this manual, allowing you to smoothly jump from one page to the other.

# Table of contents 2/2

**Assembly backrest <sup>↗</sup>**

---

**Assembly floor fastening set <sup>↗</sup>**

---

**Warnings - Text instructions -  
Maintenance <sup>↗</sup>**

## **This is an interactive PDF**

You can easily navigate through this manual, allowing you to smoothly jump from one page to the other.

# Mounting kit

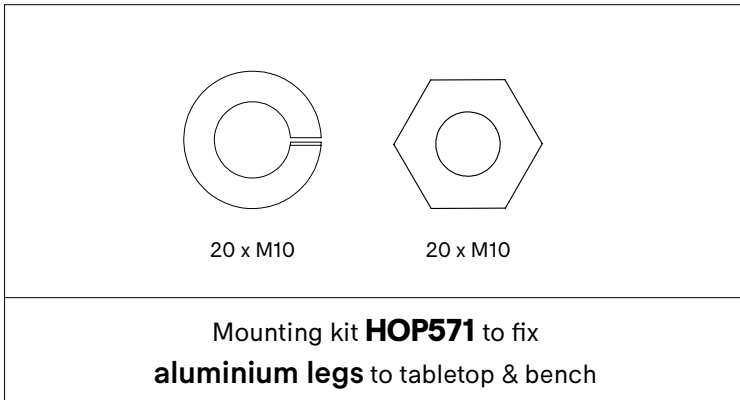
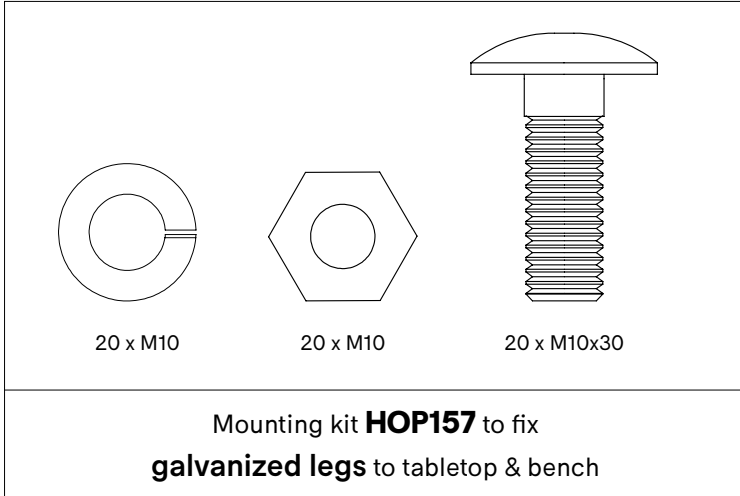

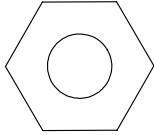

2 x M10

Mounting kit **HOW417**  
to fix **aluminium**  
**supports** to bench

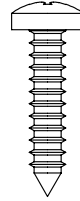

6 x 5x25

Mounting kit **HOP152** to  
fix **backrest slat** to the  
supports

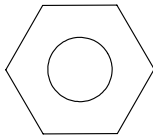

2 x M10

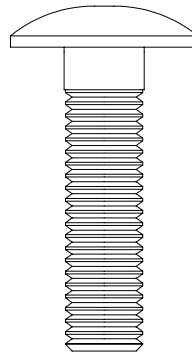

2 x M10x40

Mounting kit **HOW478** to fix  
**galvanized supports** to bench



# Exploded view

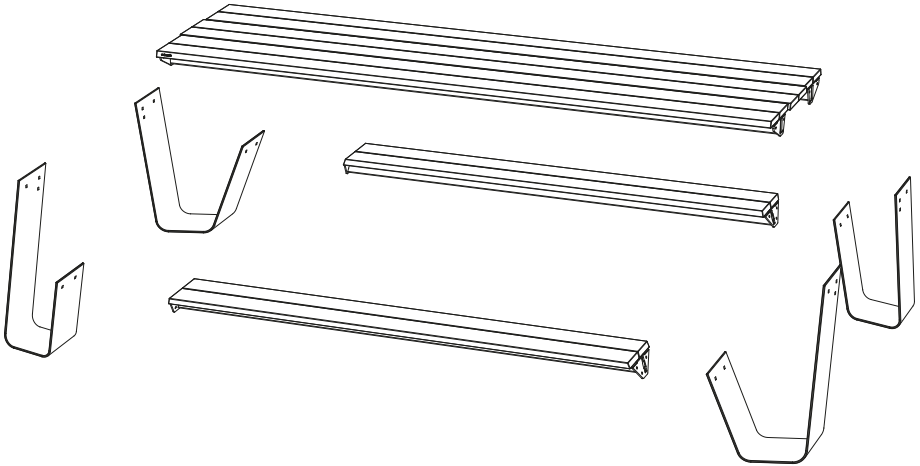



# Hopper picnic

1.

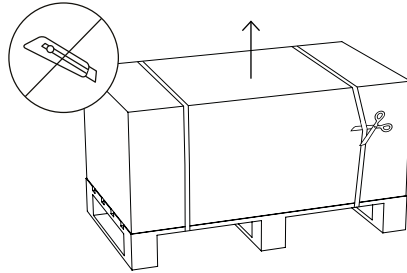

N° 17



45'



**The packaging material must stay intact for the rest of the assembly!**

2.

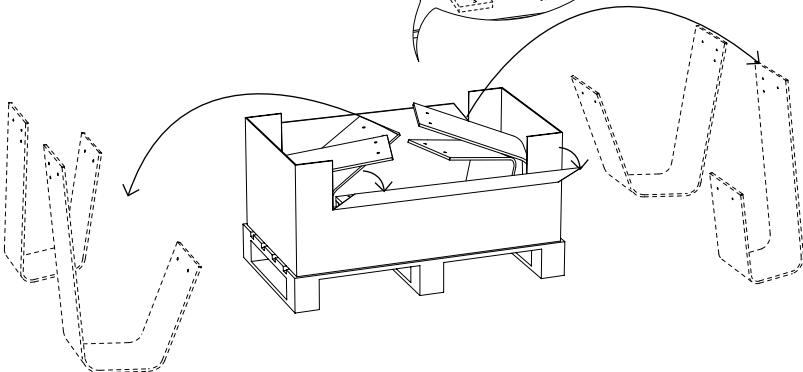
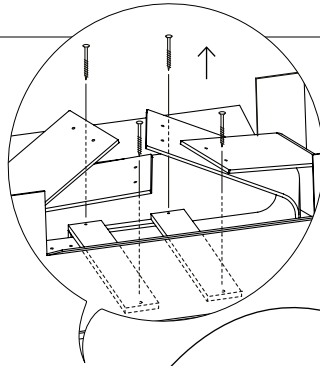
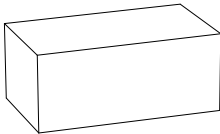

3.

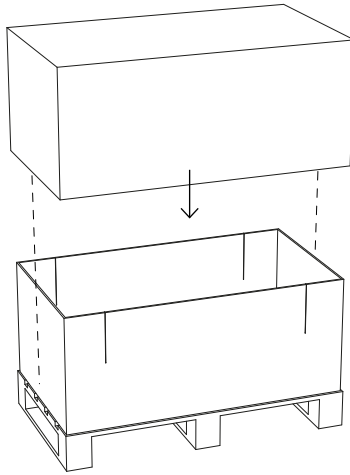

4.

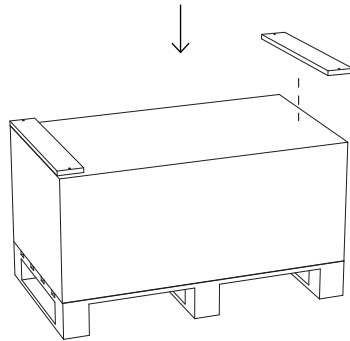

5.

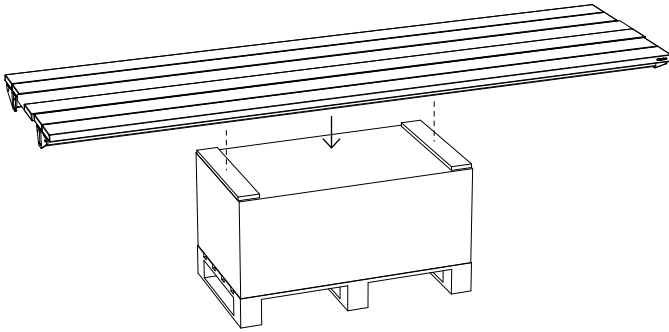

6.

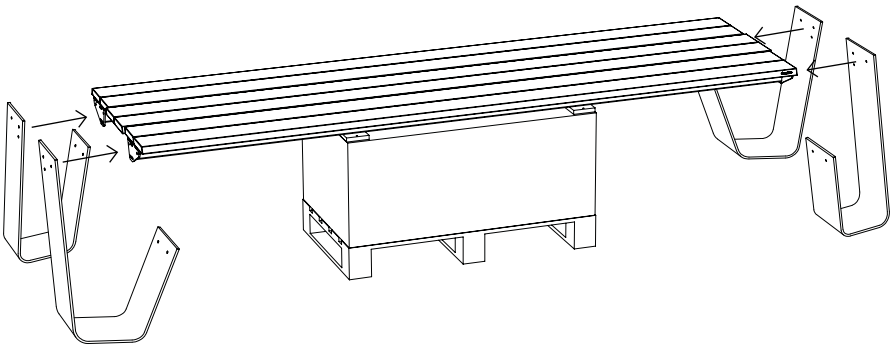

7a.

### With galvanized legs

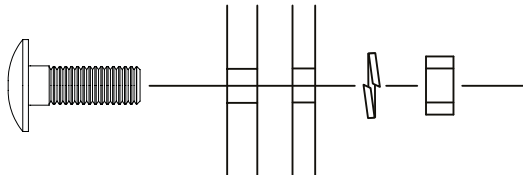
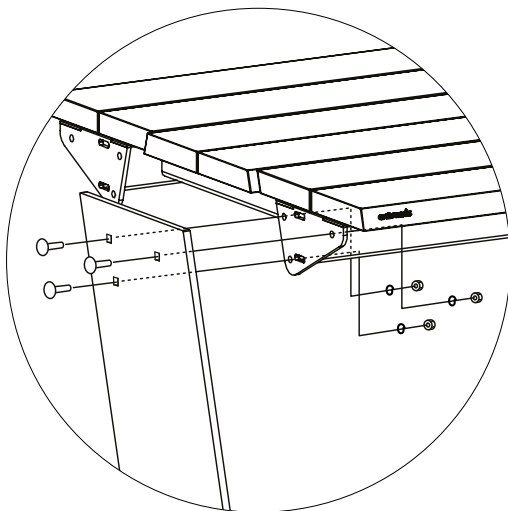

**HOP157**

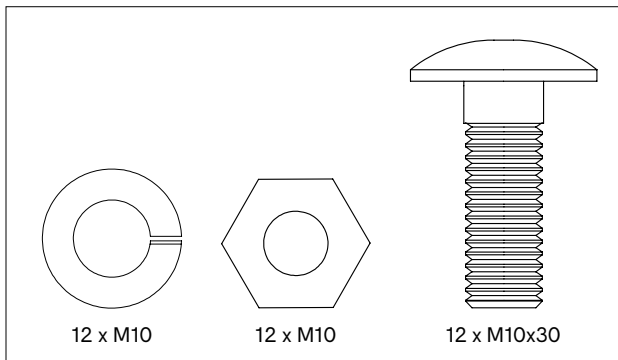

7b.

## With powder coated aluminium legs

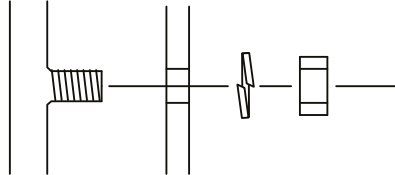
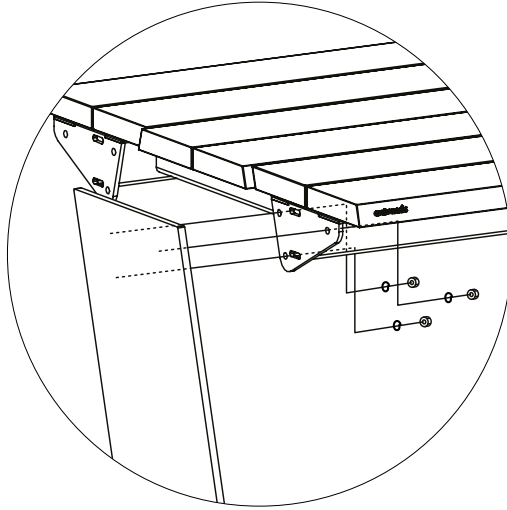

**Tighten carefully!**  
Excessive force may  
damage the coating!

  
**15 Nm  
MAX!**

**HOP571**

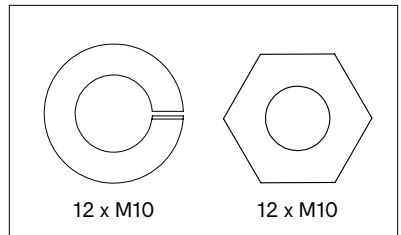

8.

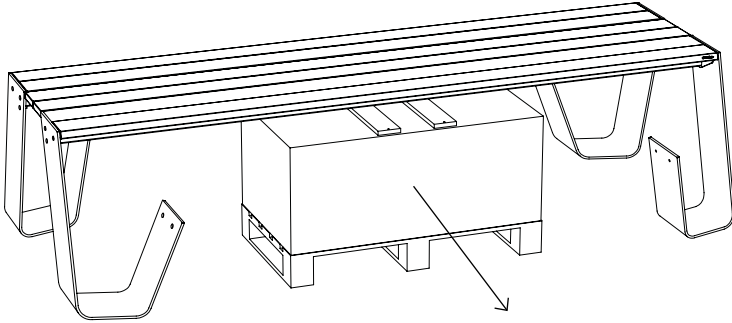

**Remove packaging before mounting the benches**

9a. Go to page 25 if you want to assemble a backrest ↗

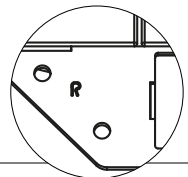
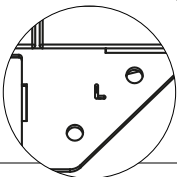
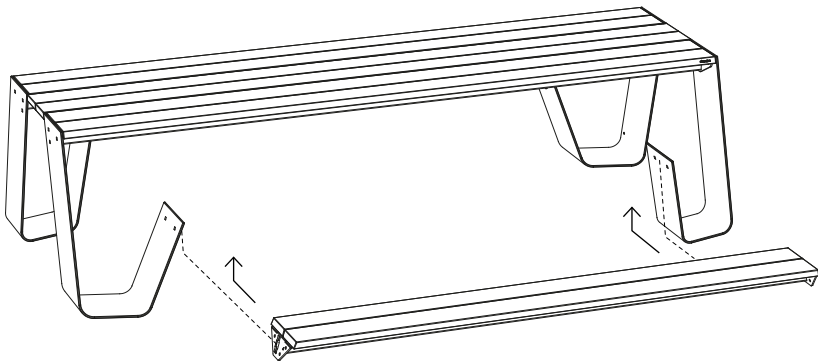

9b.

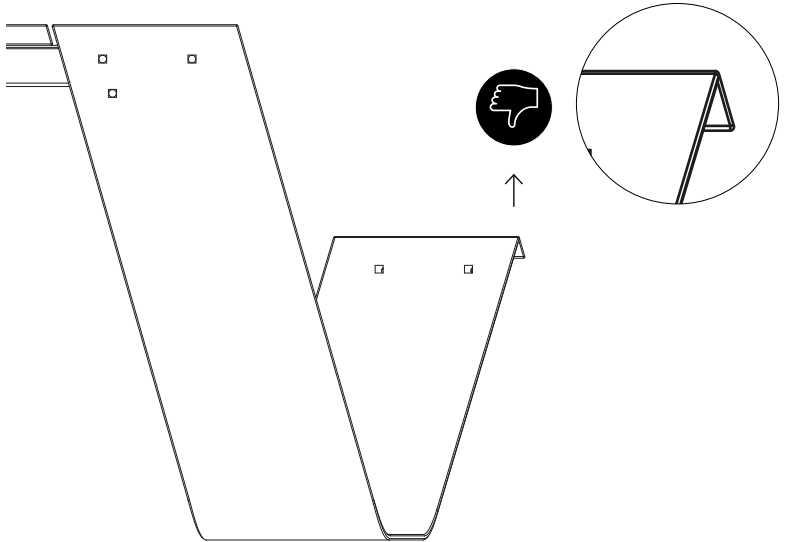
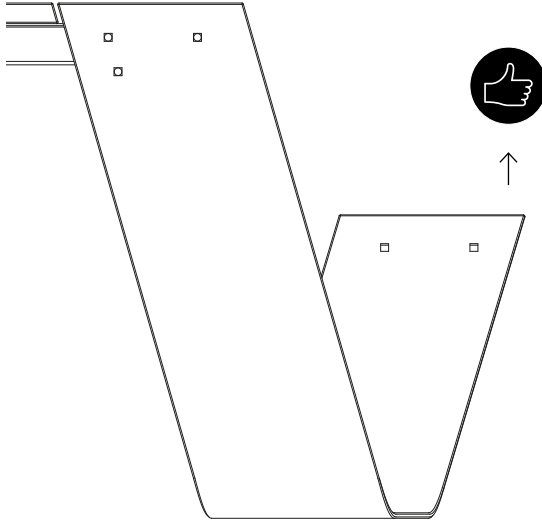

10a.

### With galvanized legs

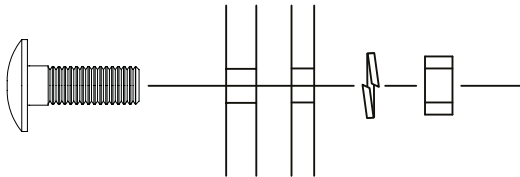
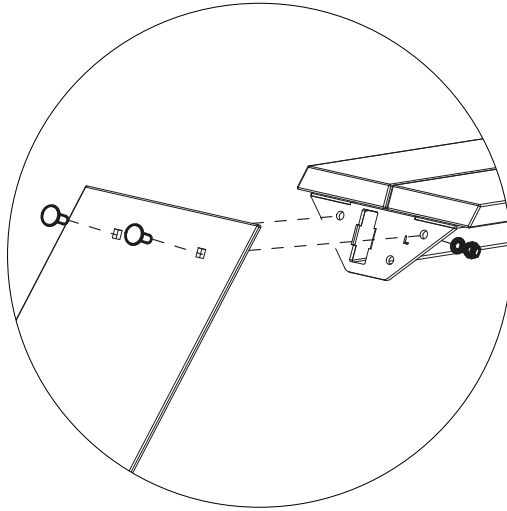

**HOP157**

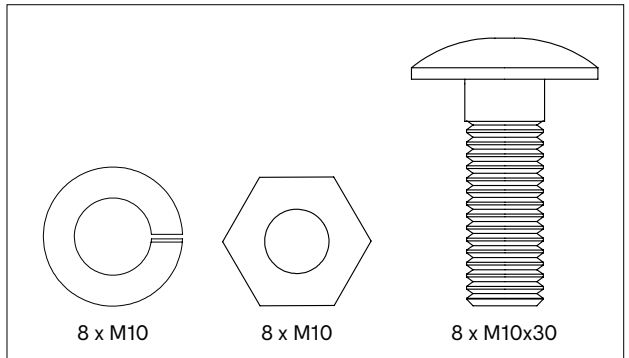



10b.

## With powder coated aluminium legs

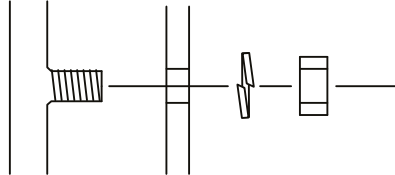
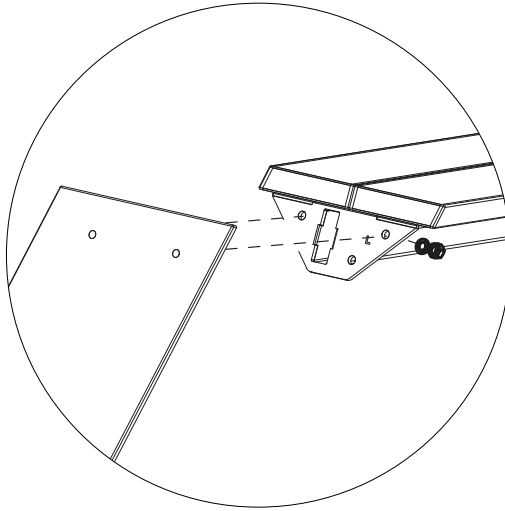

**Tighten carefully!**  
Excessive force may  
damage the coating!

  
**15 Nm  
MAX!**

**HOP571**

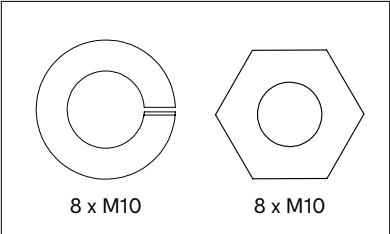

# Hopper combo

1.

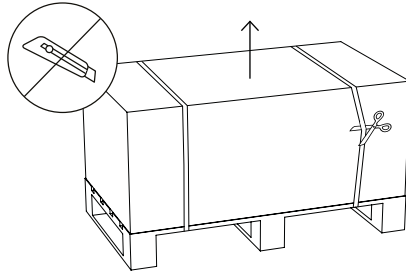

N° 17



45'



**The packaging material must stay intact for the rest of the assembly!**

2.

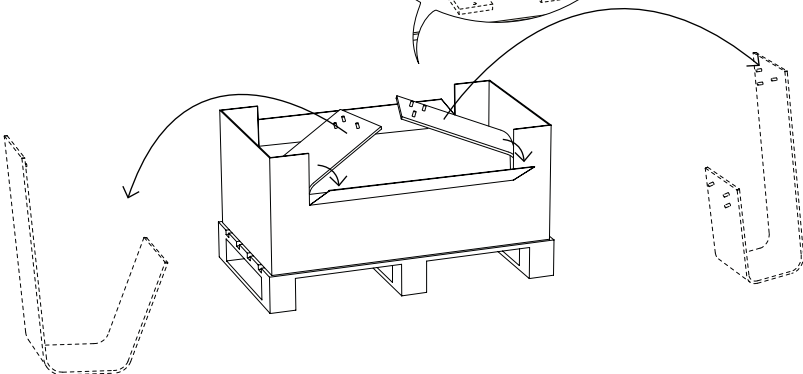
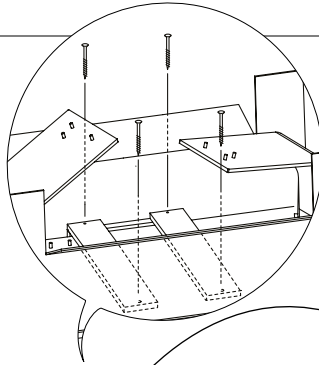
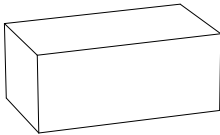

3.

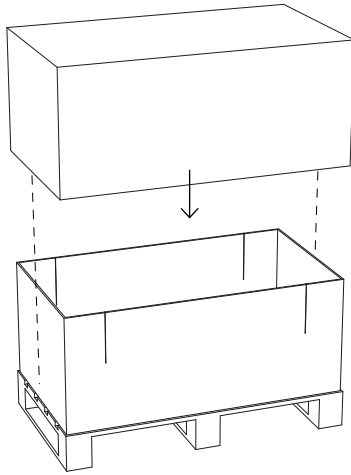

4.

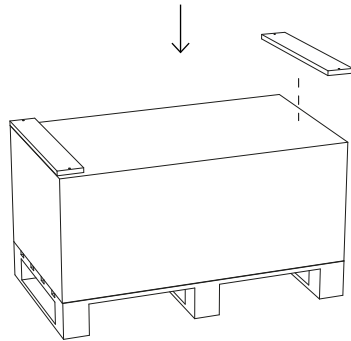

5.

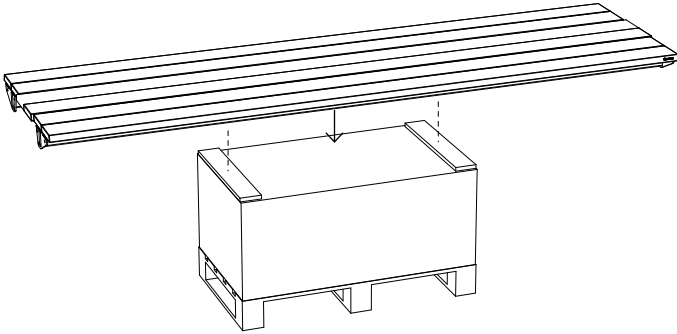

6.

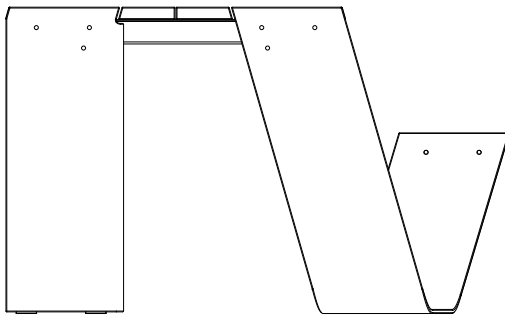
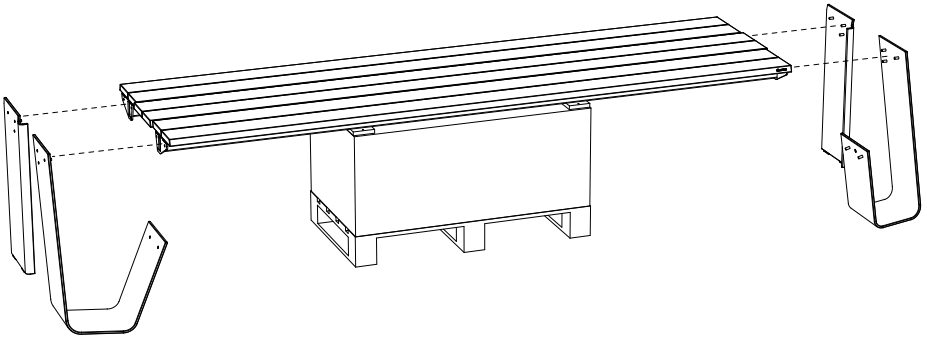

Side view

7.

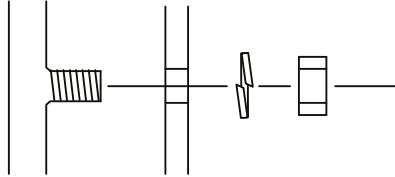
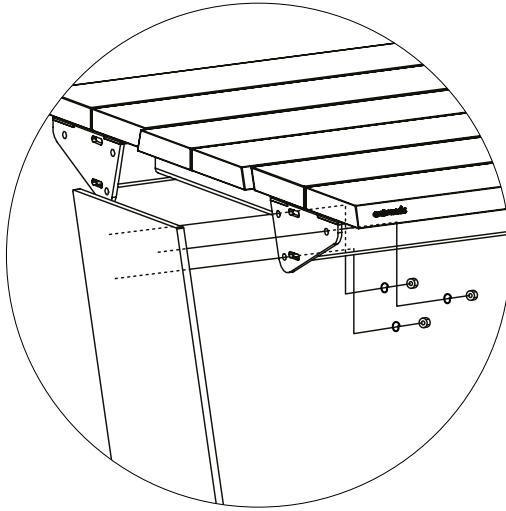

**Tighten carefully!**  
Excessive force may  
damage the coating!

  
**15 Nm  
MAX!**

**HOP571**

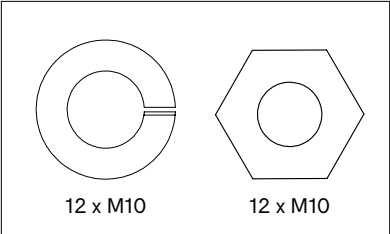

8.

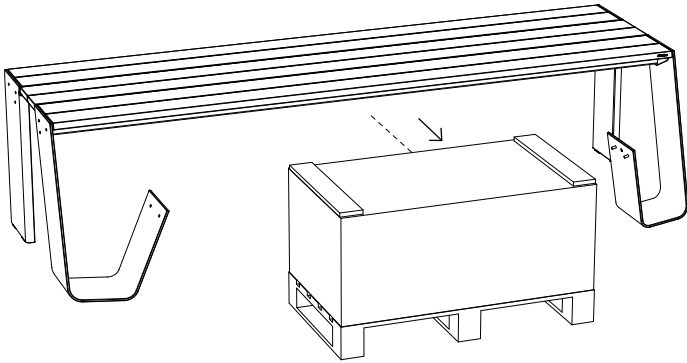

**Remove packaging before mounting the benches**

9a. Go to page 25 if you want to assemble a backrest ↗

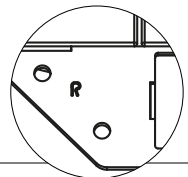
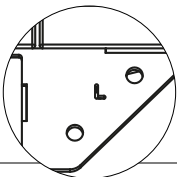
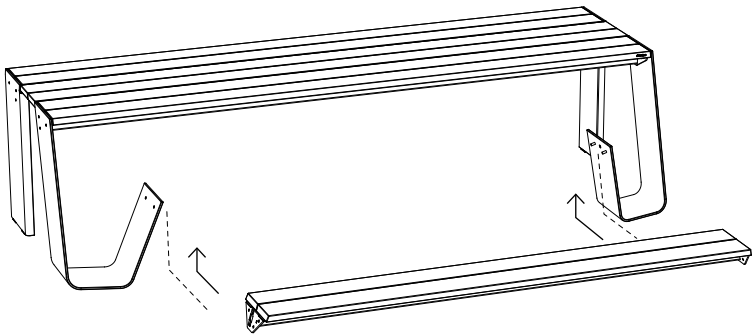

9b.

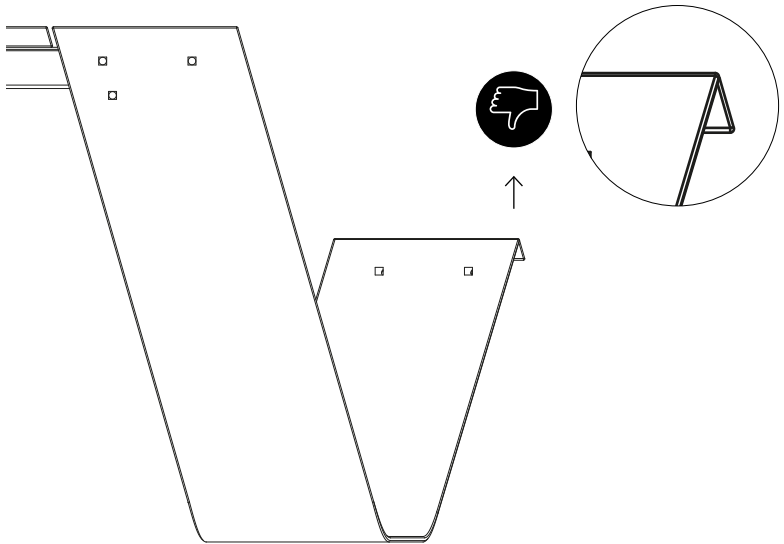
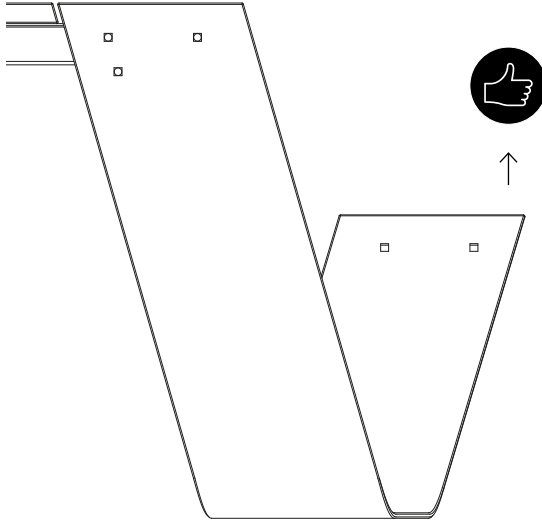

10.

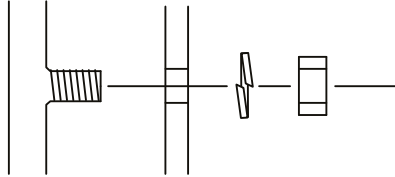
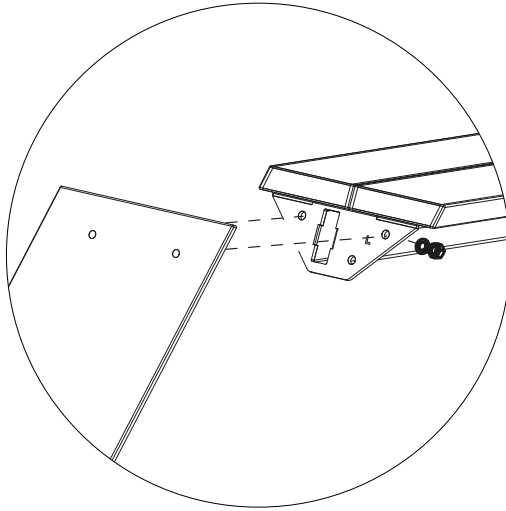

**HOP571**

**Tighten carefully!**  
Excessive force may  
damage the coating!

  
**15 Nm  
MAX!**

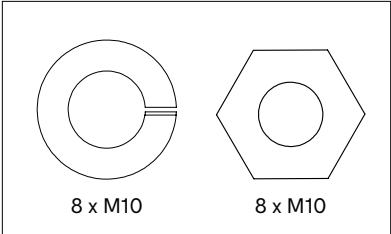



# Backrest

1a.

With galvanized legs



15'

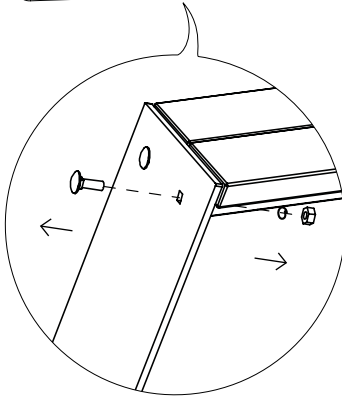
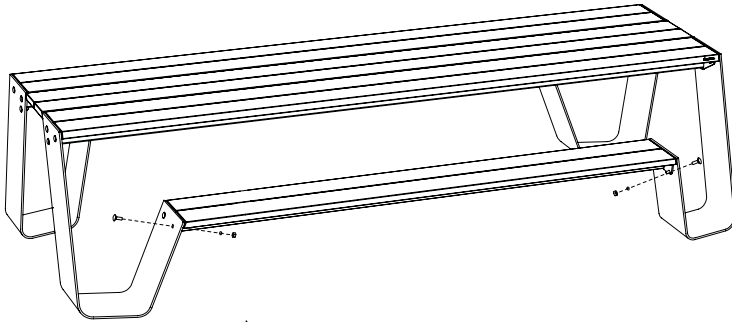

**Remove these bolts, nuts and spring washers  
at the outside of the bench**

1b.

**With powder coated aluminium legs**

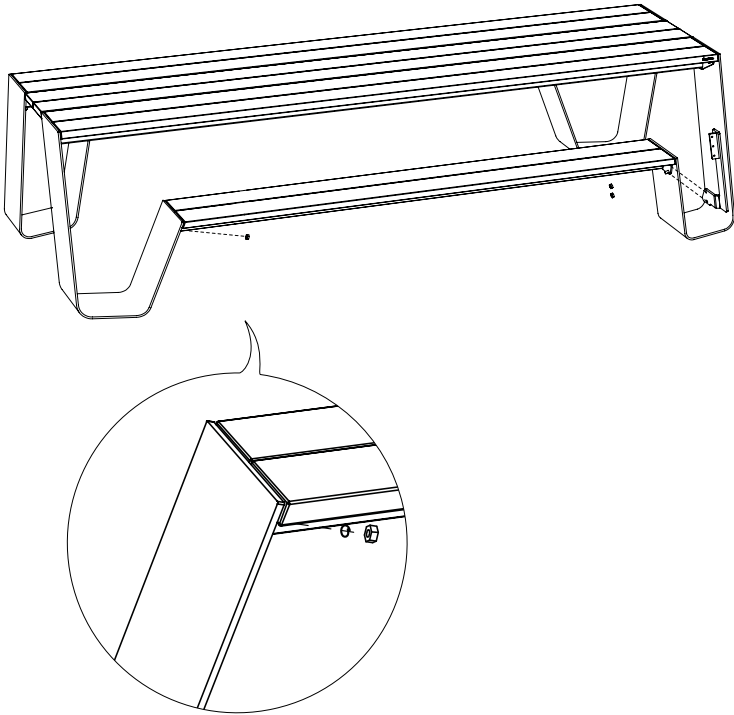

**Remove these bolts, nuts and spring washers  
at the outside of the bench**

2a.

### With galvanized legs

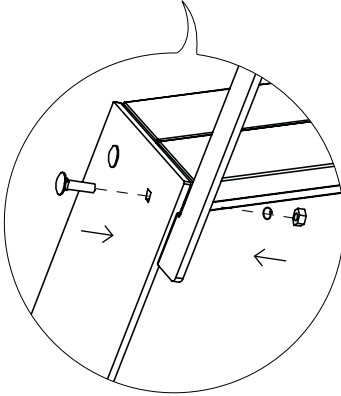
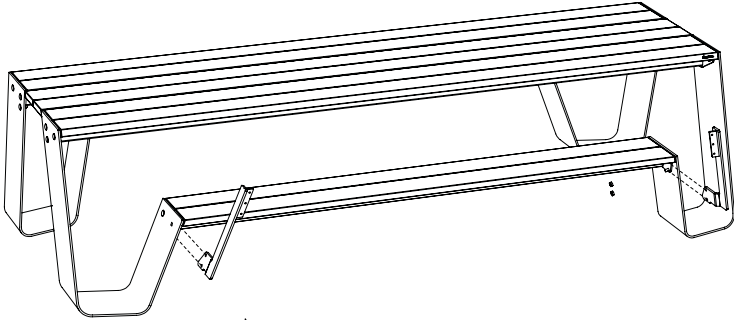

**HOP478**

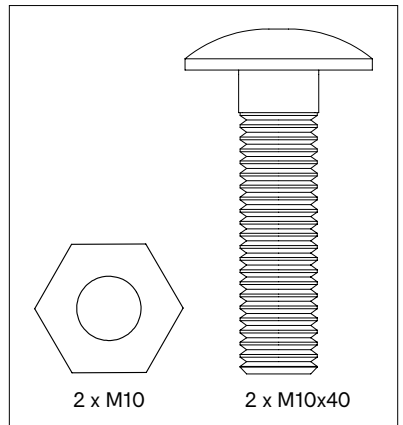

2b.

## With powder coated aluminium legs

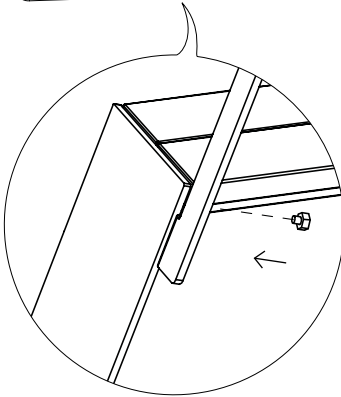
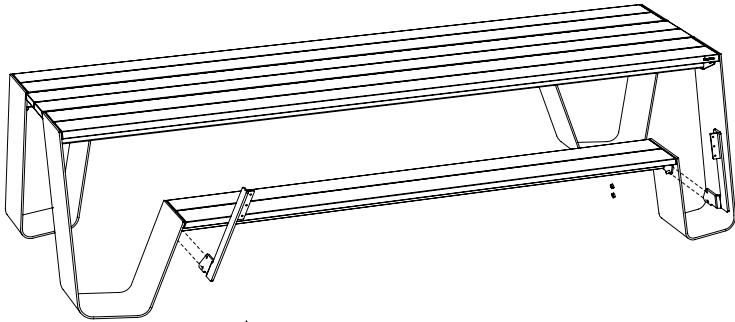

**Tighten carefully!**  
Excessive force may  
damage the coating!

  
**15 Nm  
MAX!**

**HOW417**

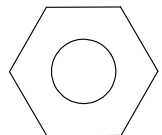

2 x M10

3.

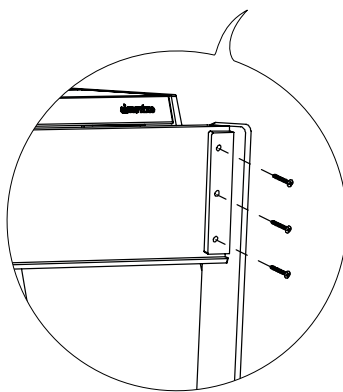
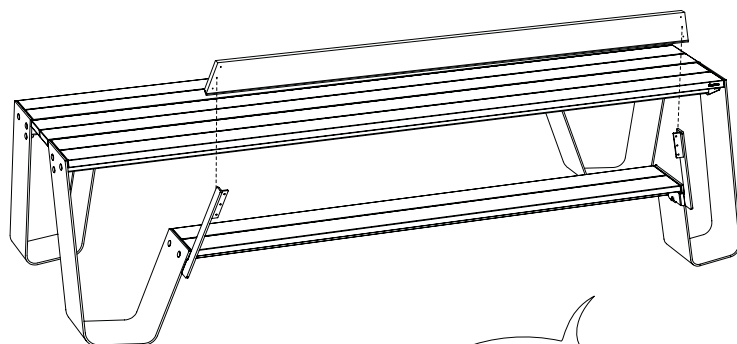

**HOP152**

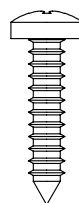

6 x 5x25

**Tighten carefully!**  
Excessive force may  
cause some damage!

10 Nm  
**MAX!**

# Floor fastening set

1.

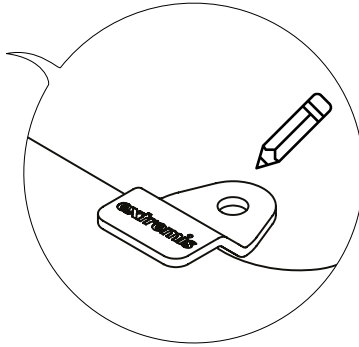
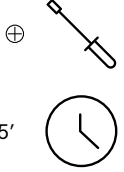
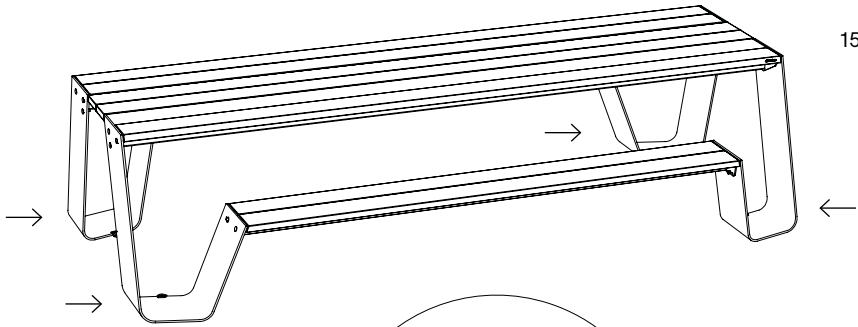

On the inside of the legs

2.

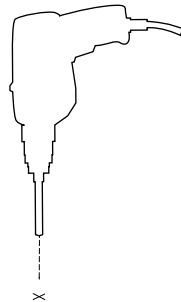

3.

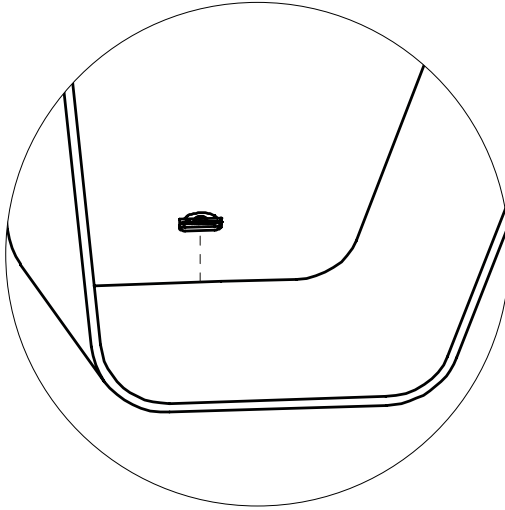

**On the inside of the table**

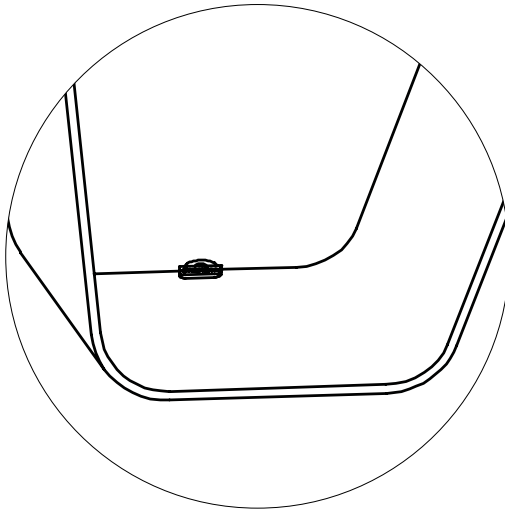

# Floor fastening

1.

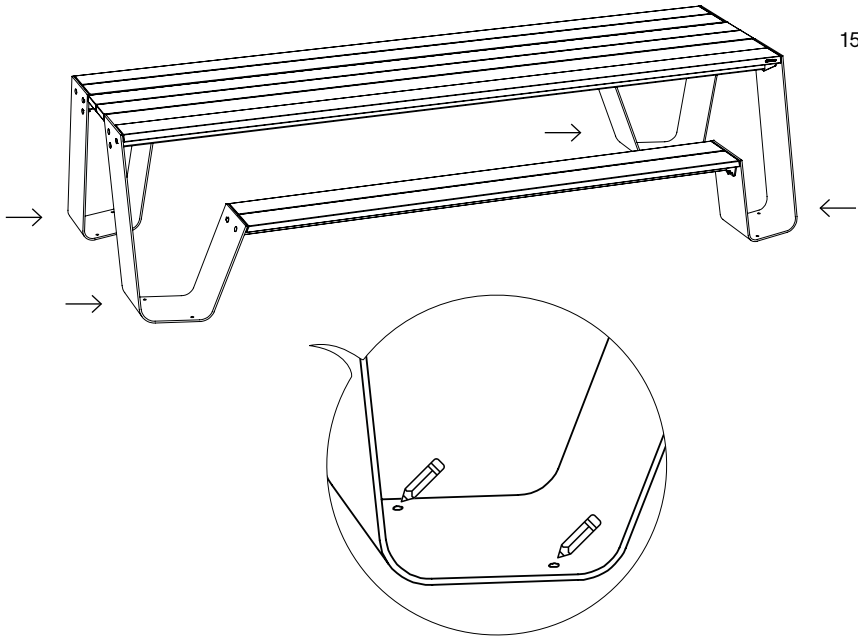

2.

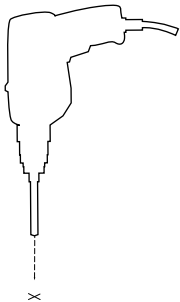

3.

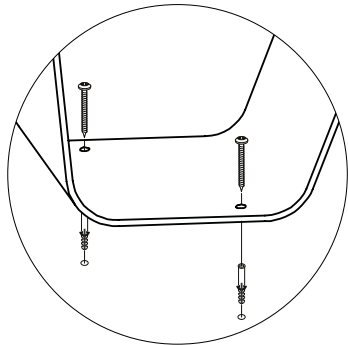



**These dimensions are theoretical  
They may vary slightly in practice**

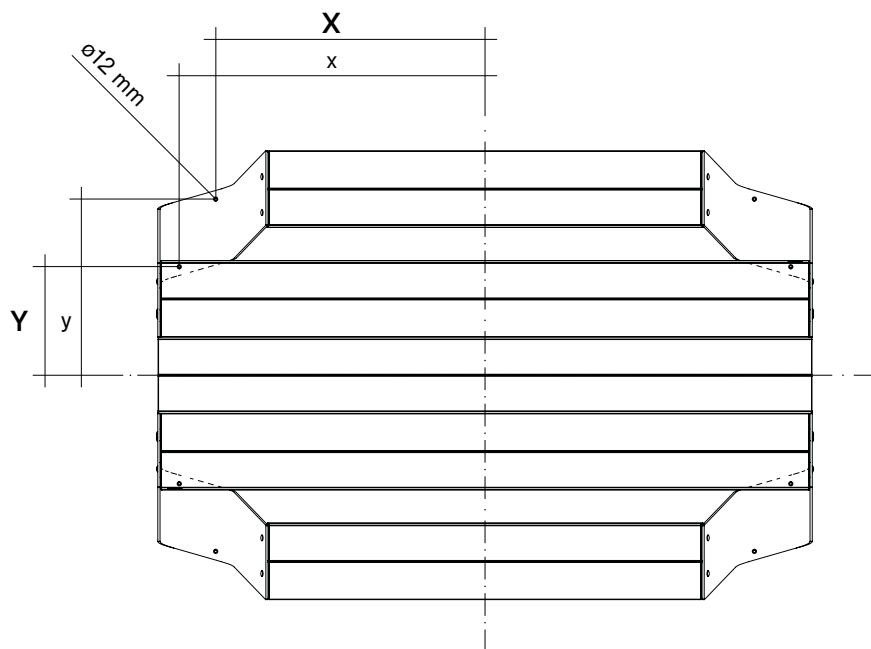

<b>Dimensions (mm)</b>	<b>X</b>	<b>x</b>	<b>Y</b>	<b>y</b>
Hopper picnic 180	1356	1620	788	1280
Hopper picnic 240	1956	2220	788	1280
Hopper picnic 300	2556	2820	788	1280
Hopper picnic 360	3156	3420	788	1280

# **Warnings**

# **Text instructions**

# **Maintenance**

**Warnings** ↗

---

**Assembly text instructions** ↗

---

**Maintenance** ↗



# Warnings

## General

- Do not use any sharp tools to open the packaging.
- We strongly advise against using power tools.
- Tripping hazard, mind your step.
- Do not put out cigarettes on the table.
- Not graffiti proof.
- Do not leave children unattended whilst playing on the table.
- To avoid danger of suffocation, keep plastic bags away from babies and children.
- Colors can differ over years and from batch to batch.

## Product

- Do not drag the table, but carry it with minimum 2 people.
- Anchoring the product has to be done by qualified people.
- For anchoring: use suitable bolts or screws from a specialized store depending on the material your terrace is made of.
- The packaging material of the legs must stay intact, you need it to attach the legs to the tabletop.
- 180 cm: max. 4 people or 320 kg per bench - 240 cm: max. 5 people or 400 kg per bench - 300 cm: max. 6 people or 480 kg per bench - 360 cm: max. 7 people or 560 kg per bench
- Regularly clean the flat surface of the legs.

## Wood

- When delivered, the wood is untreated.
- Wood is a natural material and its look is different for every slat, plank and tree.
- Wood will gradually become rougher and start to turn grey as a consequence of exposure to the sun and rain. We recommend oiling the wood once or twice a year. 1x before the Summer and 1x after the



Summer as protection for the Winter.

- Cleaning regularly with mild detergent. Never use a high pressure cleaner as this will roughen the wood's smooth surface and irreparably damage the wood's fibress.
- Thorough cleaning with Extremis Wood Cleaner.
- We strongly recommend that you treat your wood with wood oil to protect it from stains - Small cracks and crevices can also appear as part of this process. We strongly advise everyone to treat the furniture with our Wood Protector. It is best to repeat this treatment each year.

## **Galvanized steel**

- Galvanization will become less shiny when used outdoors.
- Flame retarding - NEN-EN13501-1 A1 - Class A1 products will not contribute to fire in any stage, including fully developed fire. For this reason, they are assumed to be capable of satisfying all requirements of all lower classes as well.
- Possible impurities in the immersion tank can cause black marks during galvanization, which are intrinsic to this industrial finishing technique.
- White marks on this zinc layer are also intrinsic to this procedure and will disappear when the furniture is put outdoors.
- This industrial finishing technique may result in a rougher surface. This is intrinsic to the process.

## **Powder coating**

- White powder coating requires more maintenance.
- Do not use abrasive scouring powders or scourers as they will scratch the surface.
- Color can fade to some extent when exposed to UV.
- Flame retarding - NEN-EN13501-1 A2-sl - Satisfying the same criteria as Class B for the SBI-test according to EN13823. In addition, under conditions of a fully developed fire these products will not significantly contribute to the fire load and fire growth.



- Dark colors can get very hot in sunny weather.

## **Sunbrella**

- Not waterproof, store inside!
- Shake or brush off loose dirt immediately.
- UV color fastness: 7/8 (ISO 105-B02).



# Assembly text instructions



Take a look at the drawings, starting from page 9

## Hopper picnic (p9)

1. Remove the lid of the box. The packaging material must stay intact for the rest of the assembly!
2. Remove the four screws from the two boards that prevent the table legs from moving during transport. Fold down the cardboard flaps to have better access to the legs. Take them out the box and position them as shown in the drawing (depending on the size of the table).
3. Put the lid back on the box.
4. Put the 2 boards mentioned in step 2 on top of the lid.
5. Put the tabletop with its frame facing downwards on top of the two boards. The top of the legs are now at the same height as the tabletop.
6. Position the legs to the tabletop.
7. **a. With galvanized legs** Put 3 bolts M10x30 in the square holes of each table leg. Screw the supplied nuts and spring washers onto the threaded rods, but do not tighten them yet.  
**b. With powder coated aluminium legs** Screw the supplied nuts and spring washers into the threaded rods, but do not tighten them yet.
8. Before assembling the benches, remove the packaging material from under the frame!
9. Go to page 18 if you want to assemble a backrest. Fasten the bench to the legs as shown in the drawings **a** & **b**. Now tighten all the nuts.
10. **a. With galvanized legs** Put 2 bolts M10x30 in the square holes of



each table leg. Screw the supplied nuts and spring washers onto the threaded rods.

**b. With powder coated aluminium legs** Screw the supplied nuts and spring washers into the threaded rods.

## Hopper combo (p18)

1. Remove the lid of the box. The packaging material must stay intact for the rest of the assembly!
2. Remove the four screws from the two boards that prevent the table legs from moving during transport. Fold down the cardboard flaps to have better access to the legs. Take them out the box and position them as shown in the drawing (depending on the size of the table).
3. Put the lid back on the box.
4. Put the 2 boards mentioned in step 2 on top of the lid.
5. Put the tabletop with its frame facing downwards on top of the two boards. The top of the legs are now at the same height as the tabletop.
6. Position the legs to the tabletop.
7. Screw the supplied nuts and spring washers into the threaded rods, but do not tighten them yet.
8. Before assembling the benches, remove the packaging material from under the frame!
9. Go to page 25 if you want to assemble a backrest. Fasten the bench to the legs as shown in the drawings **a** & **b**. Now tighten all the nuts.
10. Screw the supplied nuts and spring washers into the threaded rods.

## Backrest (p25)

1. **a. With galvanized legs** Unscrew the 2 nuts and spring washers at the outside of the bench frame. Now also remove the 2 bolts M10x30. The bolt and nut on the insed will prevent the bench from falling.  
**b. With powder coated aluminium legs** Unscrew the 2 nuts and spring washers at the outside of the bench frame. The nut on the insed will prevent the bench from falling.



2. **a. With galvanized legs** Position the back supports on the bottom of the bench and fasten it by inserting put 2 bolts M10x40 in the square holes on either side and screw 2 nuts & spring washer onto the threaded rods.  
**b. With powder coated aluminium legs** Position the back supports on the bottom of the bench and fasten it by 2 nuts onto the threaded rods.
3. Screw the wooden shelf to the supports, each time using 3 screws 5x25. Use the pre-drilled holes to correctly position the backrest.  
Max. 10 Nm. Excessive force may break the head of the screws.

### **Floor fastening set** (p30)

1. Position the floor fastening plates on the inside of the legs as shown on the drawing and mark the holes on the ground.
2. Remove the plates and drill holes in the marked locations.
3. Place the plates back and use the most appropriate fasteners for the surface on which the Hopper is to stand.

### **Floor fastening** (p32)

1. Mark the places on the floor where the fastening plates are to be located.
2. Remove the table and drill holes in the marked locations.
3. Use the most appropriate fasteners for the surface on which the Hopper is to stand.





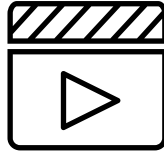

Watch the maintenance videos on our website:

[www.extremis.com/maintenance](http://www.extremis.com/maintenance)

## Wood

### OILING

Twice a year

Before first use and/or after cleaning and sanding, we strongly recommend treating the wood with Extremis Wood Protector to protect it from dirt, moisture and UV rays.

### DAY TO DAY CLEANING

Regularly and after every use

Schedule regular maintenance to prolong the life of your garden furniture Regular maintenance ensures that the furniture always looks its best.

Cleaning the wood regularly and immediately after use with a clean, damp cloth ensures that liquids cannot penetrate deep into the wood. A well oiled table is less likely to absorb liquids and thus stays cleaner for longer. To remove stubborn dirt, simply use a hard brush and some water. Be careful not to cause permanent damage to the fibres. For this reason, you should never, ever use a high-pressure washer for cleaning wood.



## THOROUGH CLEANING

### Twice a year

It is essential to clean the wood thoroughly twice a year. We recommend doing this just before spring and after summer if your furniture is outside all the year round. Pick one of those humid, cloudy days, as it is better for the moisture level in the wood to dry out slowly after cleaning.

## SANDING WOOD

### Every 2 years

After a few years, your wood will show cracks and perhaps some distortion. This is perfectly normal as wood is a natural and living material. The great advantage of solid wood is that you can sand away the top layer to make the surface even and smooth again. You should do this every two years using a hand sanding machine. Choose a dry day. Finish off with a 120-grit sandpaper.

## REPLACING A WOODEN PART

Hey! You don't need to be an engineer to understand our products. And you don't even need to be great at DIY to replace a part. Do make sure that you can't repair the damage simply by sanding the slat.

## Galvanized steel

### CLEANING

#### When dirty

Clean with lukewarm water and a brush.

## REPARING DAMAGED PARTS WITH ZINC SPRAY

### When damaged

Hot dip galvanization is the most durable way of protecting metal against rusting. If the zinc coating is damaged, the exposed metal can rust. This can easily be touched up with zinc paint that automatically has the same colour and is readily available in shops. Zinc spray forms a



quick drying, self healing and flexible coating that helps stop corrosion.

## **Powder coating**

### **CLEANING**

#### Regularly

Use Extremis Multicleaner, a 100% biodegradable detergent or common kitchen cleaning products. Avoid using aggressive products. These surfaces are best cleaned with a neutral cleaning product diluted in water.

### **REPAIRING DAMAGED POWDER COATING**

#### When damaged

The impact of sharp objects can damage the coating. Scratches or dents can be touched up with our paint pens. However this only camouflages the scratches without removing them.

## **Sunbrella**

### **SPILLED LIQUIDS**

#### Immediately after use

It is best to treat spilt liquids immediately by placing a sheet of absorbent kitchen paper on them. The water-resistant coating on the Sunbrella prevents droplets from penetrating the fabric.

### **REGULAR CLEANING**

#### When dirty

Make a solution to remove stains on your Sunbrella.

### **MACHINE WASHING**

#### Rarely

It is also possible to put the blankets and cushion covers in a washing machine (30°). Do not dry clean or tumble dry. The fabric can be creased. Ironing will help to recover the waterrepellent coating of the fabric, but only at a cool setting (delicates). As some irons exceed



the recommended temperature at the synthetic setting, test a small, inconspicuous area before ironing the entire fabric. DO NOT use a steamer or iron set to the steam setting.

If the cushion has metal brackets, we recommend turning the cover inside out first to avoid damaging the washing machine. In this case, leave the zipper open about 10 cm.

## REMOVING STUBBORN STAINS

### Only if nothing else helps

More drastic measures needed? Bleach can be used if nothing else helps. Protect the area around your Sunbrella fabric when using a bleach solution – bleach may discolour non-Sunbrella fabrics. Please be aware of the environment when cleaning with bleach. Bleach can have harmful effects on the natural environment around you. We do not advise using bleach if you are surrounded by a body of water or another environment that could be affected. If stains and/or mildew marks are severe, the quantity of bleach may be increased.





Our headquarters:  
Couthoflaan 20b  
B-8972, Poperinge  
info@extremis.com  
+ 32 57 346020

**extremis.com**

Connect with us



All rights reserved. Unless otherwise specified, all designs and photographs contained in this publication are copyright protected and are the property of Extremis. No part of this publication may be copied or distributed without Extremis' prior written consent. The names of the authors of photographs to which we do not hold rights are mentioned here. We have done our utmost to provide a comprehensive list of names. In the event of an alleged breach, please contact the editorial staff. © Extremis

LAB044-1