

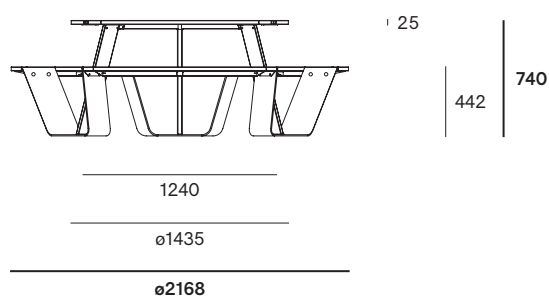

Dimensions

The Anker is available in one dimension

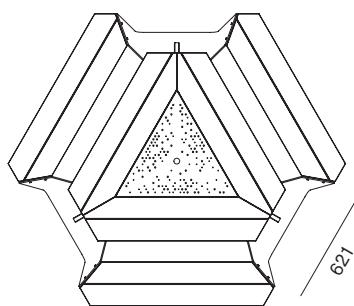

Box dimensions

The Anker comes in 4 boxes

Box 1: Tabletop



Box 2: benches

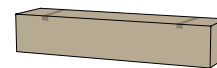

Box 3: Table legs



Box 4: Bench legs + mounting kit



Box dimensions (mm)		L	W	H	Qty	Volume (m ³)	Gross weight (kg)	Net weight (kg)	Packaging weight (kg)
Anker - Galvanized	Box 1	1450	1270	100	1	0,18	29,80	24,40	5,40
	Box 2	1270	315	240	1	0,10	24,80	24,60	0,20
	Box 3	790	130	130	1	0,01	9,40	9,00	0,40
	Box 4	670	820	225	1	0,12	53,90	50,40	3,50
	Total:					0,41	117,90	108,40	8,50
Anker - Powder coated	Box 1	1450	1270	100	1	0,18	29,80	24,40	5,40
	Box 2	1270	315	240	1	0,10	24,80	24,60	0,20
	Box 3	790	130	130	1	0,01	9,40	9,00	0,40
	Box 4	670	820	225	1	0,12	53,90	50,40	3,50
	Total:					0,41	117,90	108,40	8,50

Floor fastening

The floor fastening is available in one dimension

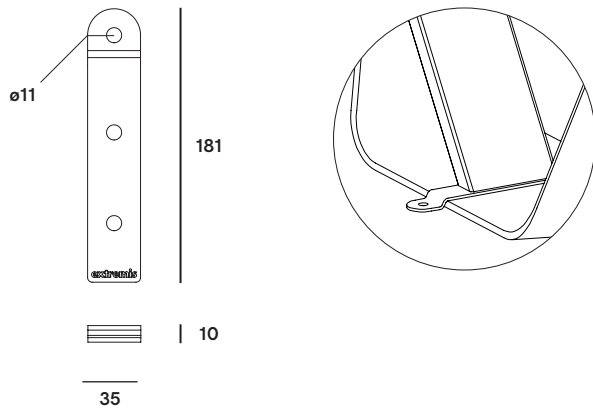

Floor fastening box

The floor fastening comes in 1 box

Box 5: floor fastening



Box dimensions (mm)		L	W	H	Qty	Volume (m ³)	Gross weight (kg)	Net weight (kg)	Packaging weight (kg)
Floor fastening	Box 5	200	140	140	1	0,01	0,53	0,43	0,10

Anker with Inumbrina medium

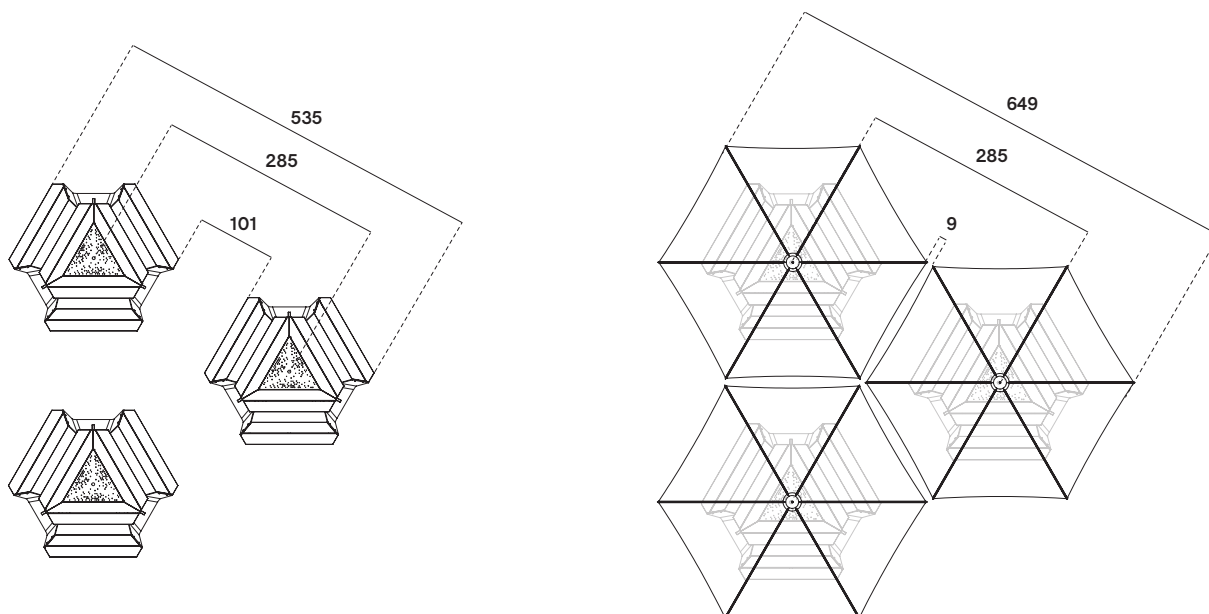
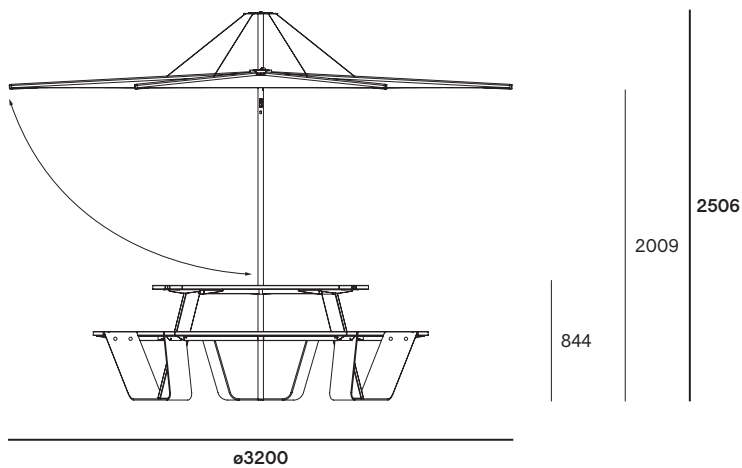

Tabletop & benches

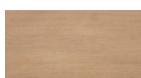

Iroko hardwood



Hellwood

Frame



Galvanized steel

Legs

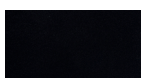

Black (RAL9005)
Structured powder coating



Earth
Structured powder coating



Off white (RAL9002)
Structured powder coating

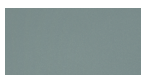

Verdigris
Structured powder coating



Galvanized steel

Tabletop centerplate

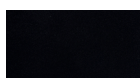

Black (RAL9005)
Structured powder coating



Earth
Structured powder coating



Off white (RAL9002)
Structured powder coating



Verdigris
Structured powder coating

Materials	Key facts	Thickness	Layer thickness	Density	In/outdoor	Water	UV color fastness	Flame retarding
		mm	micron					
Iroko tabletop & benches	<ul style="list-style-type: none"> Durability CLASS 1 Feels comfortable in all weather conditions Advisable to oil the wood 	25	n.a.	600 à 700 kg/m ³	Outdoor & indoor	n.a.	Untreated wood turns grey after a while	/
Hellwood tabletop & benches	<ul style="list-style-type: none"> Durability CLASS 1 Feels comfortable in all weather conditions Advisable to oil the wood 	25	n.a.	600 kg/m ³	Outdoor & indoor	n.a.	Untreated wood turns grey after a while	/
Hot dip galvanized steel frame & legs	<ul style="list-style-type: none"> Most durable method for protecting metal from rusting Protective layer Very long life span 100% recyclable Cradle to Cradle Certified™ 	3	50 - 100	7,50 10 ³ kg/m ³	Outdoor & indoor	n.a.	Very good, galvanization will however become less shiny when used outdoors	NEN-EN13501-1 A1 *
Structured powder coated aluminium table legs	<ul style="list-style-type: none"> A technique of applying dry paint to a part Electrostatically charged and sprayed onto the object More scratch-resistant than non structured powder coating 	8	60	7,50 10 ³ kg/m ³	Outdoor & indoor	n.a.	Very good: color can fade to some extent when exposed to UV	NEN-EN13501-1 A2-s1 **
Structured powder coated ZnAlMg steel tabletop centerplate	<ul style="list-style-type: none"> A technique of applying dry paint to a part Electrostatically charged and sprayed onto the object More scratch-resistant than non structured powder coating 	1,50	60	7,50 10 ³ kg/m ³	Outdoor & indoor	n.a.	Very good: color can fade to some extent when exposed to UV	NEN-EN13501-1 A2-s1 **
Structured powder coated electro galvanized steel bench support	<ul style="list-style-type: none"> Electro galvanized (for an extra protection against rust), then powder coated Protective layer Very long life span 100% recyclable More scratch-resistant than non structured powder coating 	8	50 - 100	7,50 10 ³ kg/m ³	Outdoor & indoor	n.a.	Very good, galvanization will however become less shiny when used outdoors	NEN-EN13501-1 A1 *

NEN-EN13501-1 A1

Class A1 products will not contribute to fire in any stage, including fully developed fire. For this reason, they are assumed to be capable of satisfying all requirements of all lower classes as well.

NEN-EN13501-1 A2-s1

Satisfying the same criteria as class B for the SBI-test according to EN 13823. In addition, under conditions of a fully developed fire these products will not significantly contribute to the fire load and fire growth

Good to know

- The hole in the tabletop to place a parasol in is $\varnothing 35$ mm.
- Anker combines perfectly with Inumbrina medium, no parasol foot needed.



F.A.Q.

Q: Do you need to oil the wood?

A: Just like other types of wood, wood will gradually become rougher and start to turn grey as a consequence of exposure to the sun and rain. Small cracks and crevices can also appear as part of this process. We strongly advise everyone to treat the furniture with our Wood Protector. This 100% natural oil controls the moisture level within the wood, which makes the planks stay stable for longer, and the layer of oil also helps to prevent spilled liquids from being absorbed, so that stains tend to stay superficial. It is best to repeat this treatment at regular intervals.

Maintenance

POWDER COATED PARTS

- White powder coating obviously requires more maintenance.

GALVANIZED PARTS

- Clean with lukewarm water and a mild detergent or Extremis multi cleaner.

WOOD

- Clean regularly with mild detergent.
- Thorough cleaning with Extremis Wood Cleaner.
- Oil the wood with Extremis Wood Protector. We recommend oiling the wood at regular intervals depending from location and general weather conditions.
- In order to smoothen the surface again after a thorough cleaning, lightly sand your wood with 80 grit sanding paper or a sanding pad.

RECOMMENDED USE

- For Extremis Wood protector:



3 to 5 wood care treatments



1 to 3 wood care treatments



200 - 300 ml for one Anker

Floor fastening

Anker can be fixed to the floor with our anchoring set (to be ordered separately): three jugged steel plates to be fixed with bolts.



Fun fact

We have provided a little hook underneath the tabletop to hang purses, bags, etc.

Warnings

General

- Do not use any sharp tools to open the packaging.
- We strongly advise against using power tools.
- Tripping hazard, mind your step.
- Do not put out cigarettes on the table.
- Not graffiti proof.
- Do not leave children unattended whilst playing on the table.
- To avoid danger of suffocation, keep plastic bags away from babies and children.
- Colors can differ over years and from batch to batch.

Product

- Do not stand or jump on the table.
- Do not drag the table, but carry it with minimum 2 people.
- Anchoring the product has to be done by qualified people.
- For anchoring: use suitable bolts or screws from a specialized store depending on the material your terrace is made of.
- Clean the flat part of the legs regularly.
- Do not put your fingers in the holes of the tabletop.
- Max. 3 people or 240 kg per bench.

Wood

- When delivered, the wood is untreated.
- Wood is a natural material and its look is different for every slat, plank and tree.
- Wood will gradually become rougher and start to turn grey as a consequence of exposure to the sun and rain. We recommend oiling the wood at regular intervals depending from location and general weather conditions.
- Clean regularly with mild detergent. Never use a high pressure cleaner as this will roughen the wood's smooth surface and irreparably damage the wood's fiber.
- Thorough cleaning with Extremis Wood Cleaner.
- We strongly recommend that you treat your wood with wood protector to protect it from stains - small cracks and crevices can also appear as part of this process. We strongly advise everyone to treat the furniture with our Wood Protector.

Galvanized steel

- Galvanization will become less shiny when used outdoors.
- Flame retarding - NEN-EN13501-1 A1 - Class A1 products will not contribute to fire in any stage,

including fully developed fire. For this reason, they are assumed to be capable of satisfying all requirements of all lower classes as well.

- Possible impurities in the immersion tank can cause black marks during galvanization, which are intrinsic to this industrial finishing technique.
- White marks on this zinc layer are also intrinsic to this procedure and will disappear when the furniture is put outdoors.
- This industrial finishing technique may result in a rougher surface. This is intrinsic to the process.

Powder coating

- White powder coating requires more maintenance.
- Do not use abrasive scouring powders or scourers as they will scratch the surface.
- Color can fade to some extent when exposed to UV.
- Flame retarding - NEN-EN13501-1 A2-sl - Satisfying the same criteria as Class B for the SBI-test according to EN13823. In addition, under conditions of a fully developed fire these products will not significantly contribute to the fire load and fire growth.
- Dark colors can get very hot in sunny weather.

The content of this document, in particular the mentioned models, is protected by copyrights and/or design rights. The present document and its content is communicated to you for information purposes only. Any partial or total reproduction or any other use without our prior written permission is strictly prohibited. This technical sheet remains subject to possible changes. **All dimensions are in mm**, unless mentioned otherwise. Extremis is not responsible for the errors in the documentation of products. All measurements are approximate and are provided for informational purposes only.

Tech sheet
20240417