

Walrus

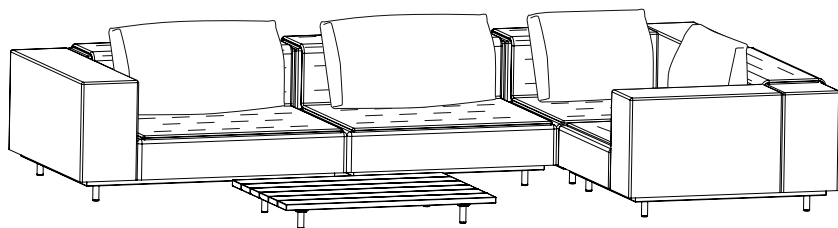

extremis®



**IMPORTANT! RETAIN FOR FUTURE
REFERENCE: READ CAREFULLY.**

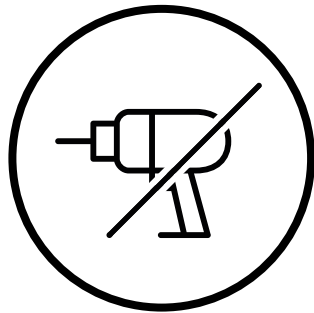
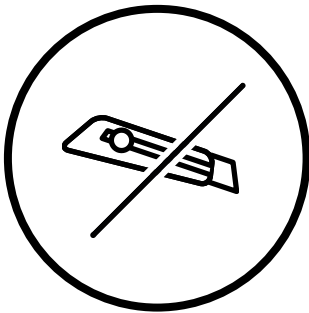

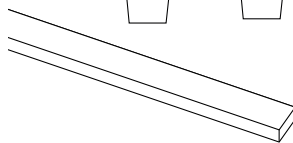
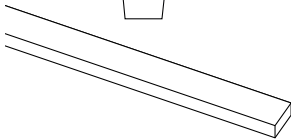
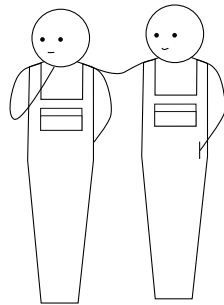
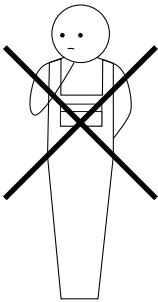
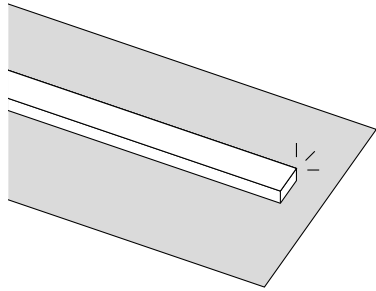

Table of contents ^{1/5}

Mounting kit [↗]

Different frame sizes [↗]

Assembly Club chair 110 [↗]

Assembly Club chair 80 [↗]

This is an interactive PDF

You can easily navigate through this manual, allowing you to smoothly jump from one page to the other.

Table of contents ^{2/5}

Assembly Corner seat 110 [↗]

Assembly Corner seat 80 [↗]

Assembly Middle seat 110 [↗]

Assembly Middle seat 80 [↗]

This is an interactive PDF

You can easily navigate through this manual, allowing you to smoothly jump from one page to the other.

Table of contents 3/5

**Assembly Seat
with side table 110 ↗**

**Assembly Seat
with side table 80 ↗**

**Assembly Corner seat
with side table 110 ↗**

**Assembly Corner seat
with side table 80 ↗**

This is an interactive PDF

You can easily navigate through this manual, allowing you to smoothly jump from one page to the other.

Table of contents ^{4/5}

**Assembly Seat
with 2 side tables 110 ↗**

**Assembly Seat
with 2 side tables 80 ↗**

**Assembly Blanket &
comfort cushion ↗**

Assembly Footstool ↗

This is an interactive PDF

You can easily navigate through this manual, allowing you to smoothly jump from one page to the other.

Table of contents 5/5

Assembly connection piece [↗]

Assembly coffee tables [↗]

Assembly linking table [↗]

**Warnings - Text instructions -
Maintenance [↗]**

This is an interactive PDF

You can easily navigate through this manual, allowing you to smoothly jump from one page to the other.

Mounting kit

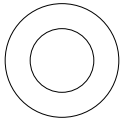

3 x M8

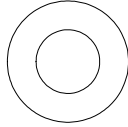

3 x M8

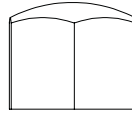

3 x M8

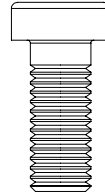

3 x M8x20

Mounting kit **WAL155** to fix one
back- or arm cushion to the frame

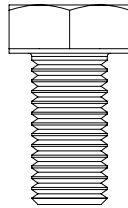

4 x M10x20

Mounting kit **WAL157** to fix
the **feet** to the frame

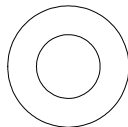

4 x M8

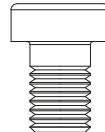

4 x M8x12

Mounting kit **WAL181** to fix
one **side table** to the frame



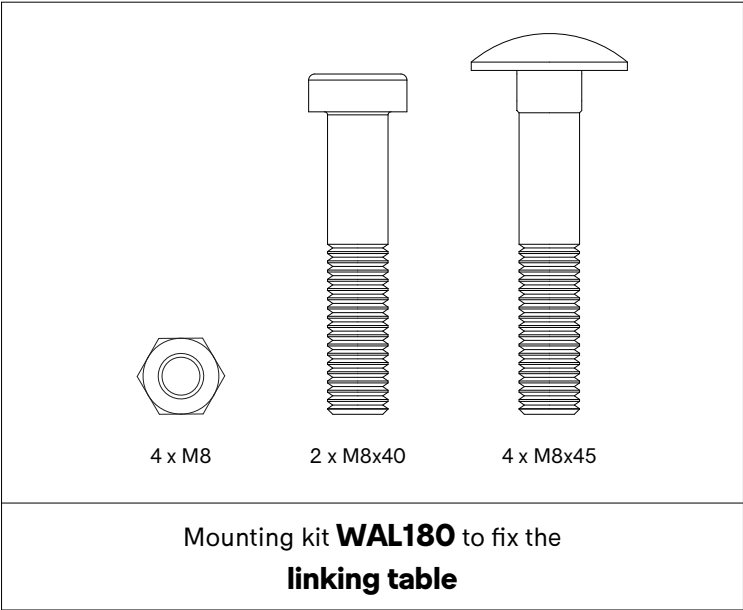
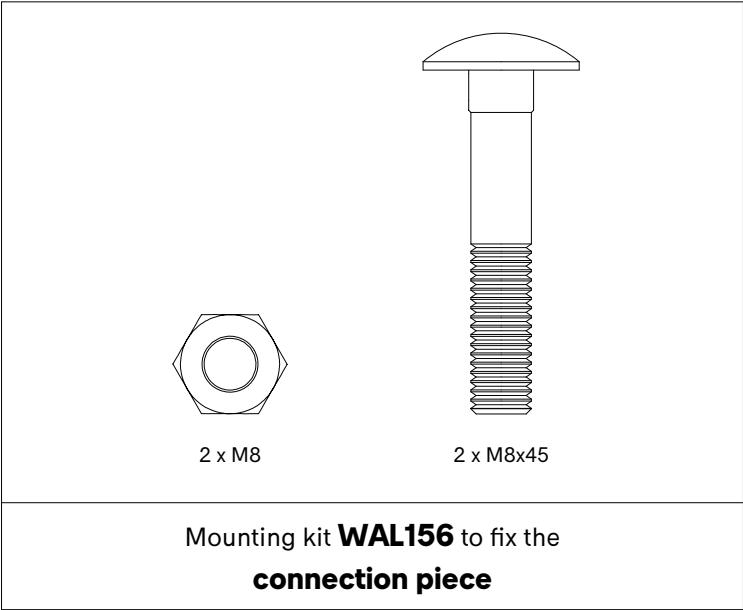

Different frame sizes

Club chair 110

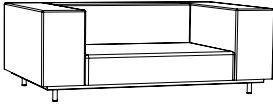

Seat with 2 side tables 110

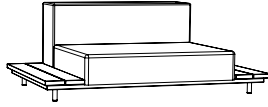

Corner seat with side table 110

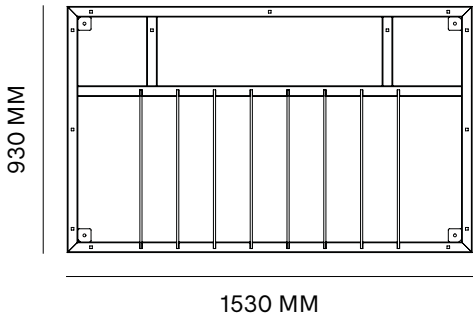
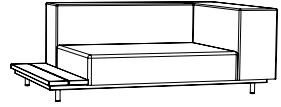

Corner seat 110

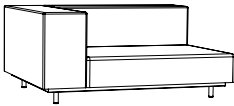

Club chair 80

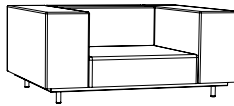

Seat with 2 side tables 80

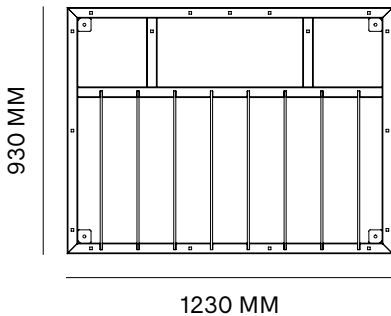
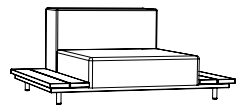

Seat with side table 110

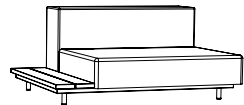

Corner seat with side table 80

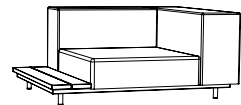

Middle seat 110

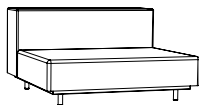

Corner seat 80

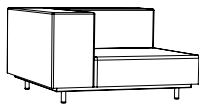

Seat with side table 80

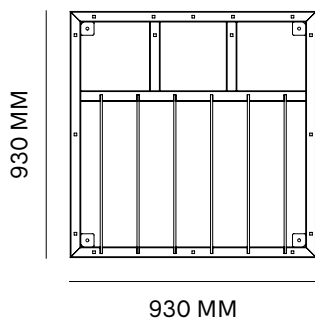
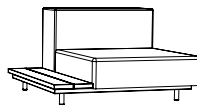

Footstool



Middle seat 80

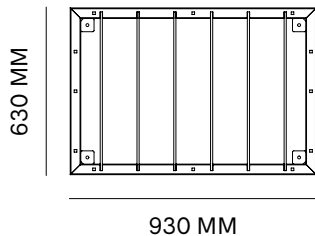
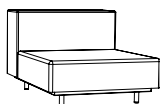

Club chair 110 cm wide seating

1.

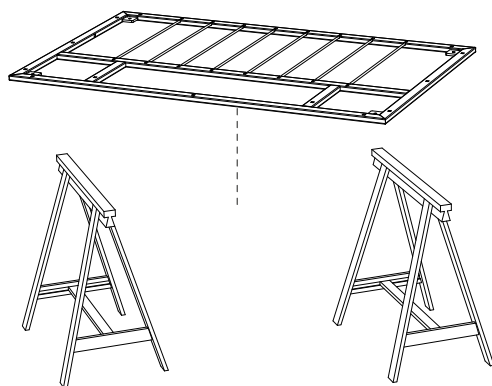

N° 17



N° 5



30'



Place the frame on two trestles

2.

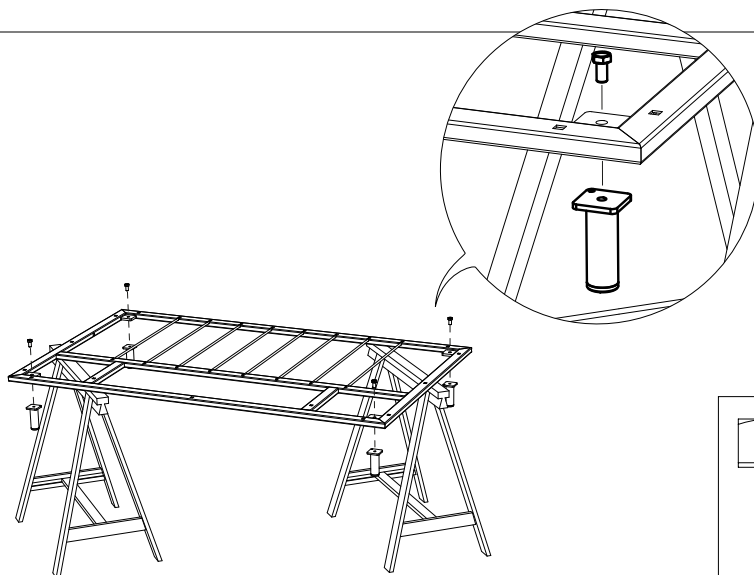

Tighten all bolts!

WAL157

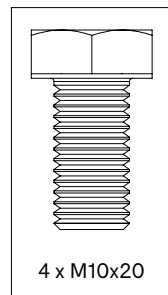

4 x M10x20



3.

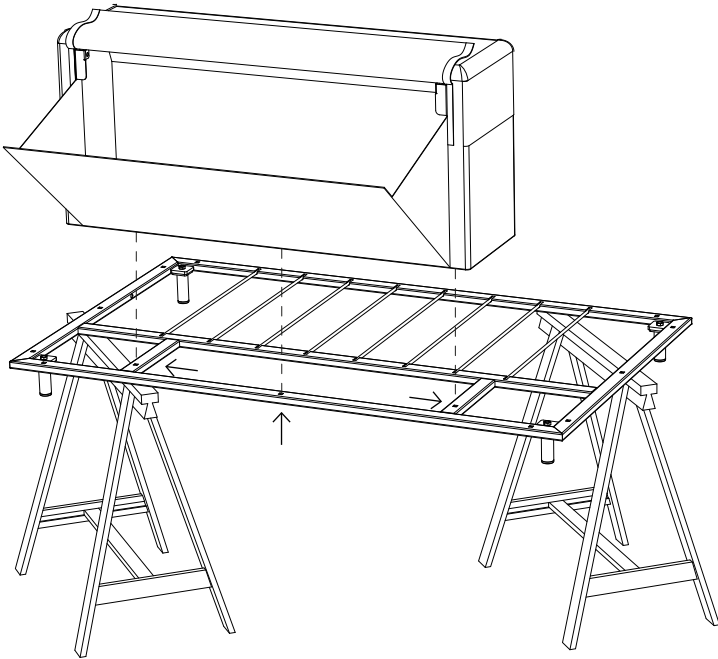

Position the backrest in the middle of the back of the frame (the side with no rods)

4.

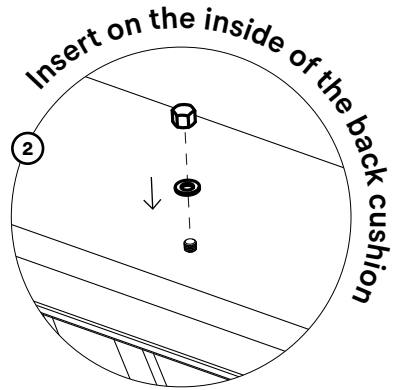
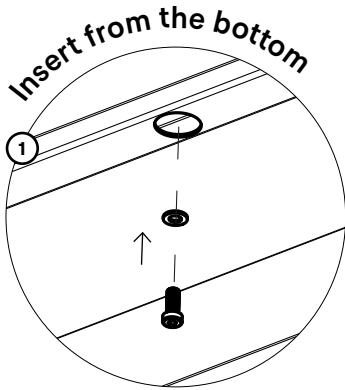
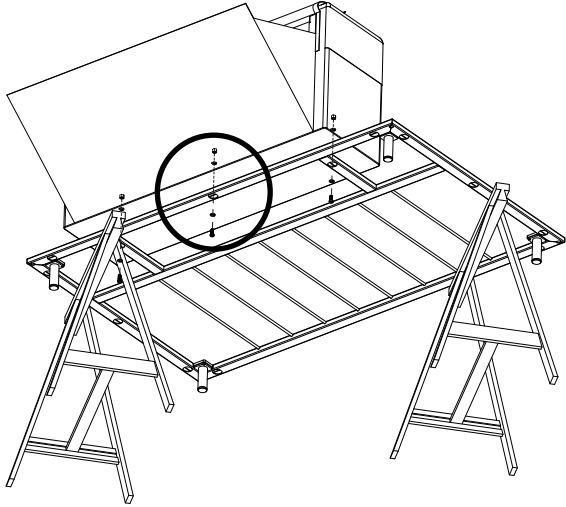

WAL155

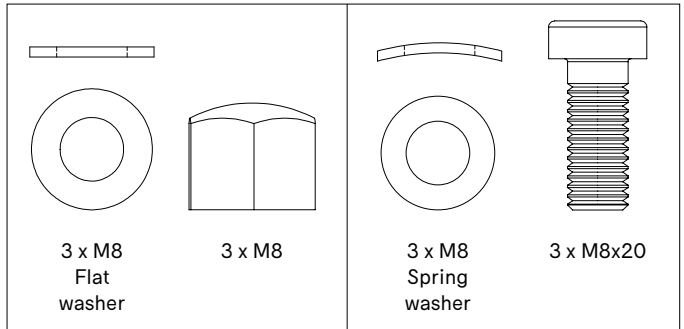

Tighten the bolts!

5.

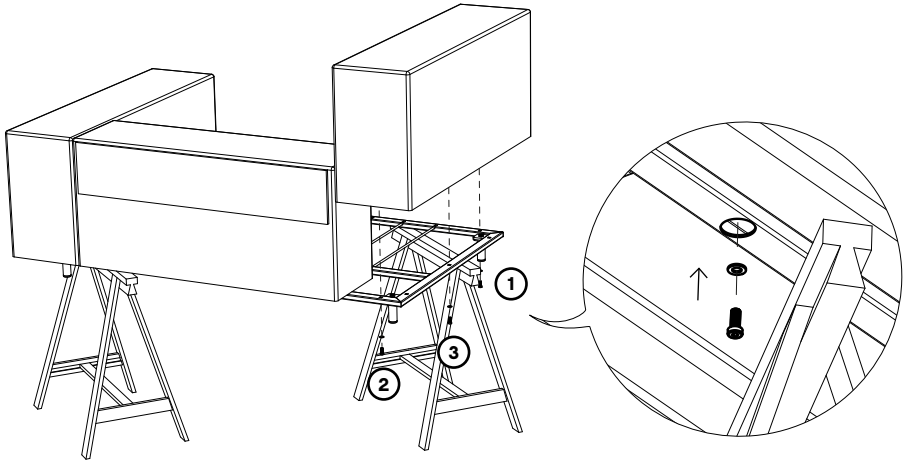

Attach both armrests to the frame

Tip: First position the bolt in the front, then the one in the back and finally the center bolt.

Tighten all bolts!

WAL155

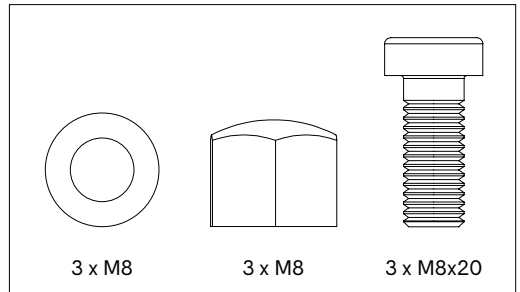

6.

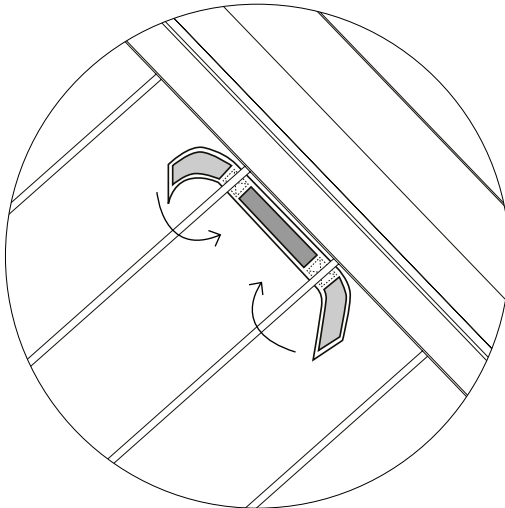
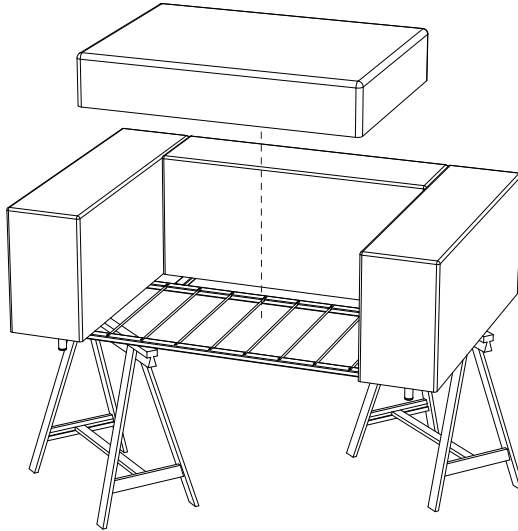

**Fix the seating cushion to the frame attaching the
Velcro straps to the rods**

Remove the trestles

Club chair 80 cm wide seating

1.

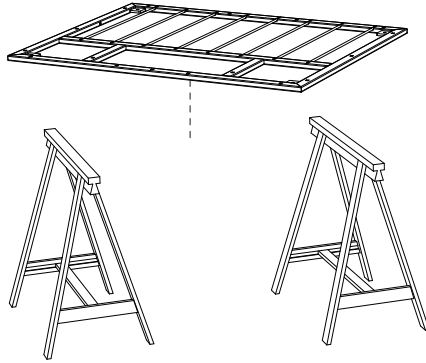

N° 17



N° 5



30'



Place the frame on two trestles

2.

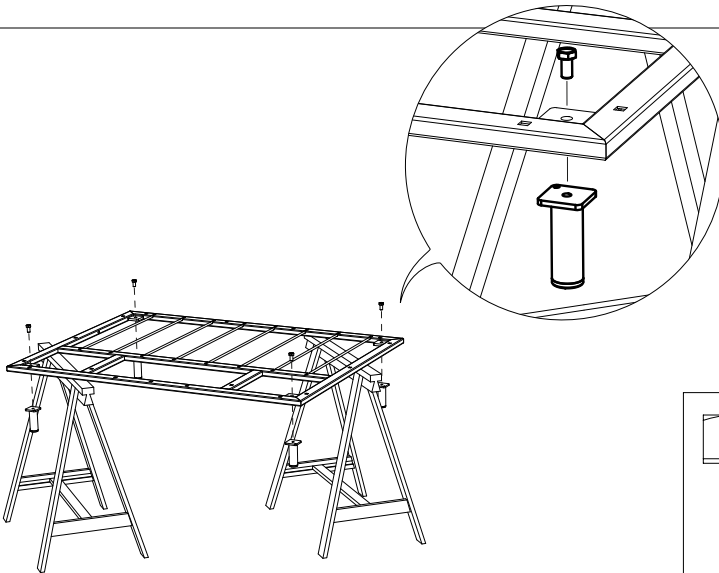

Tighten all bolts!

WAL157

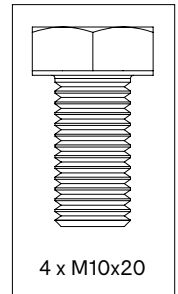

4 x M10x20



3.

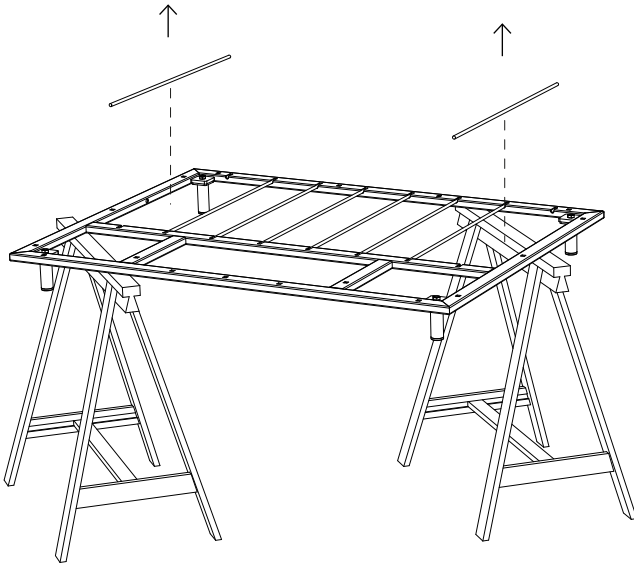

Remove the fiberglass rods on both sides

4.

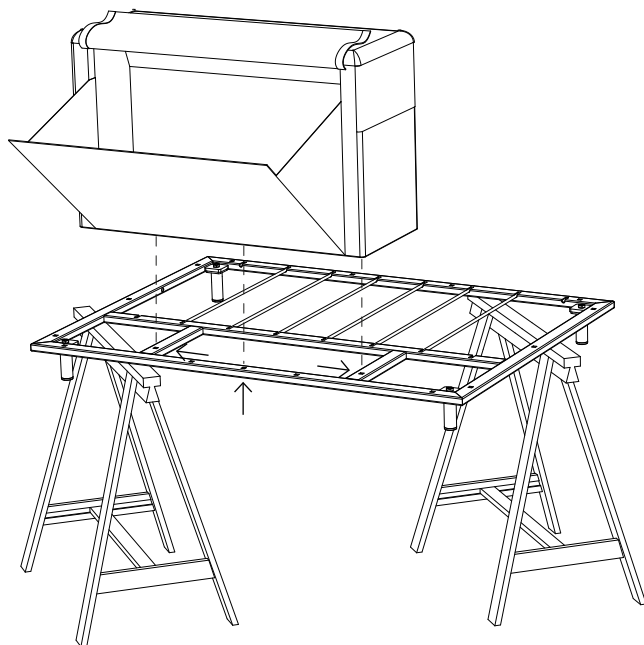

Position the backrest in the middle of the back of the frame (the side with no rods)

5.

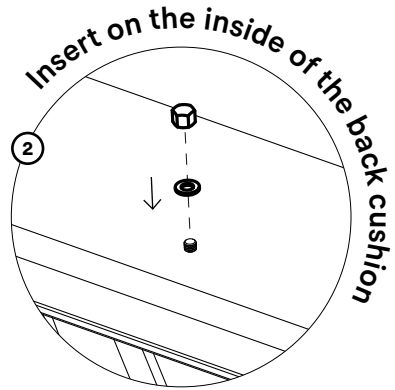
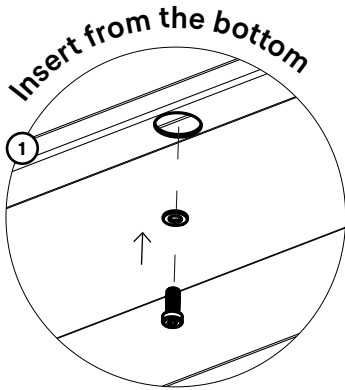
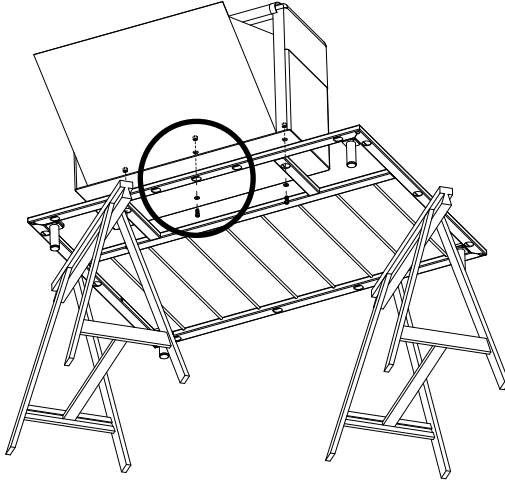

WAL155

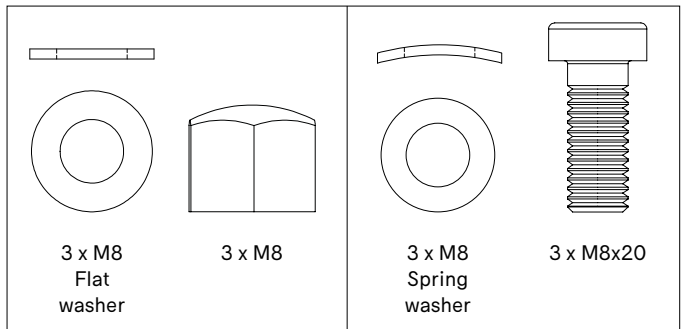

Tighten the bolts!

6.

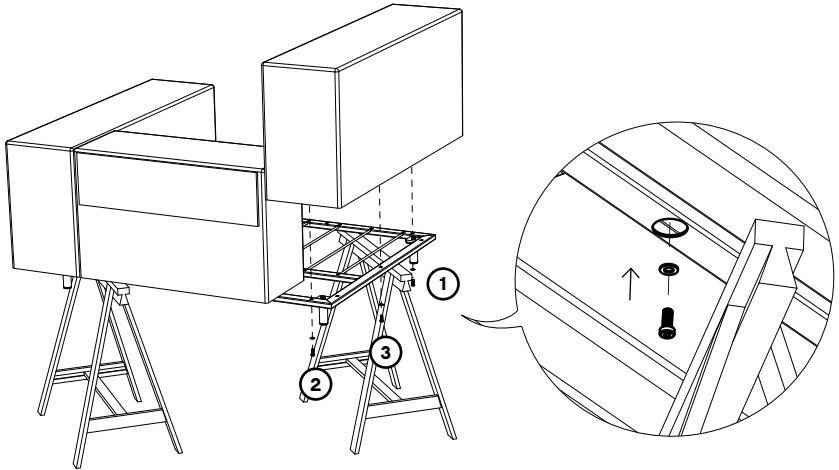

Attach both armrests to the frame

Tip: First position the bolt in the front, then the one in the back and finally the center bolt.

Tighten all bolts!

WAL155

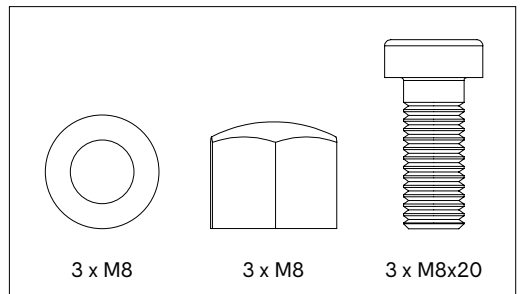

7.

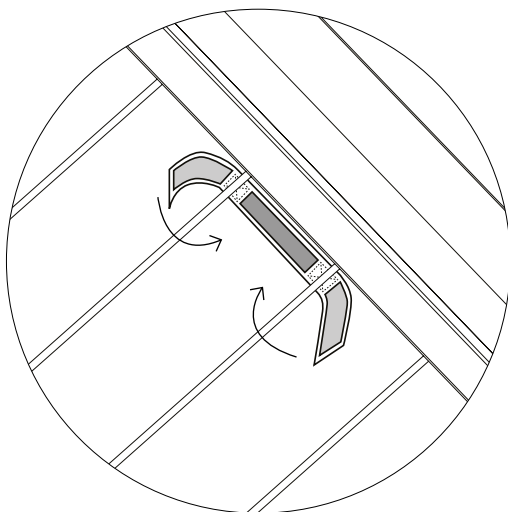
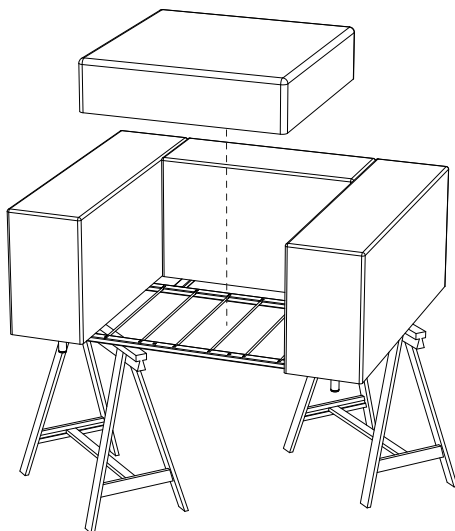

**Fix the seating cushion to the frame attaching the
Velcro straps to the rods**

Remove the trestles

Corner seat 110 cm wide seating

1.

N° 17



N° 5



25'

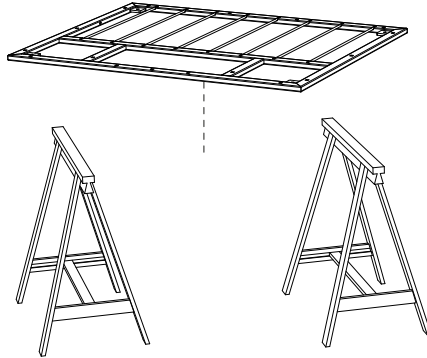

Place the frame on two trestles

2.

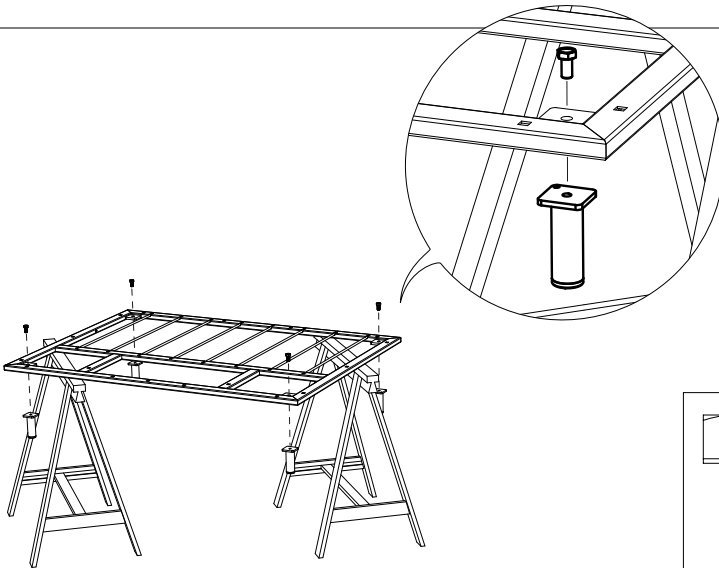

Tighten all bolts!

WAL157

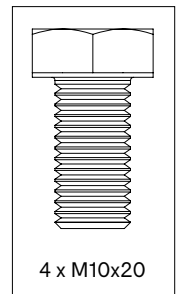

4 x M10x20



3.

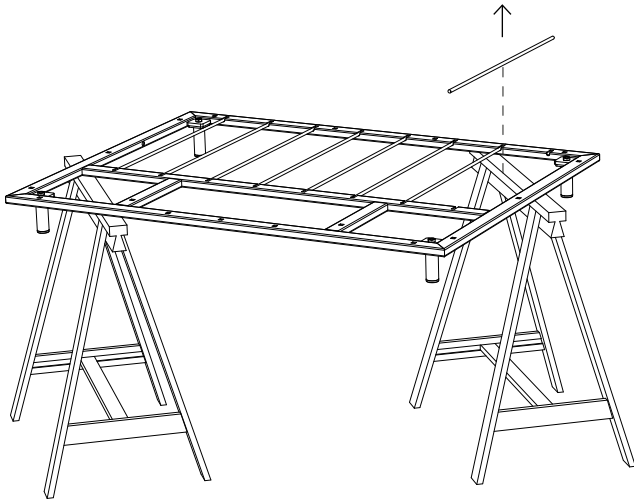

Remove the fiberglass rod on the side where you want to fit the armrest (left or right)

4.

Choose if you want a left or right corner seat

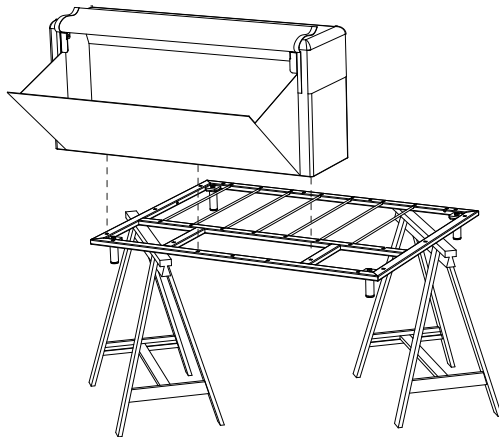
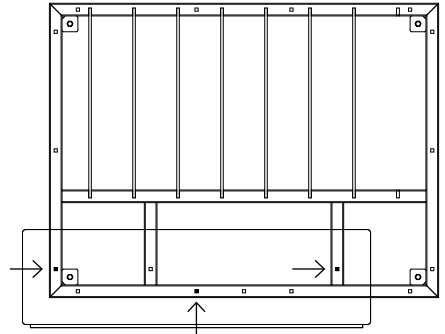
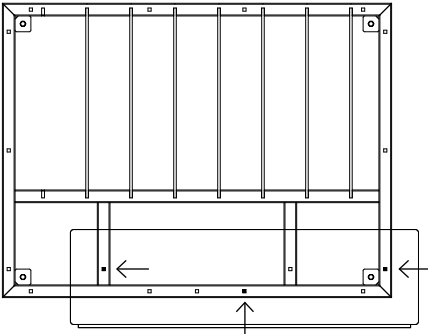
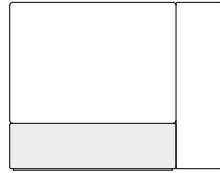
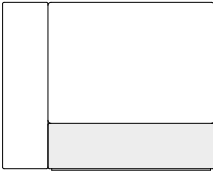

Position the backrest on of the back of the frame
(the side with no rods)

5.

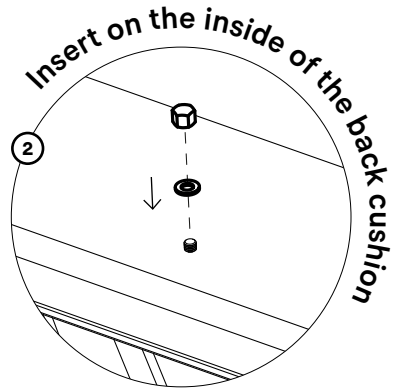
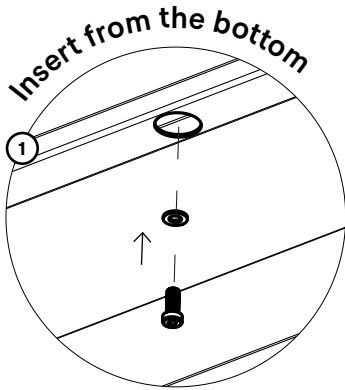
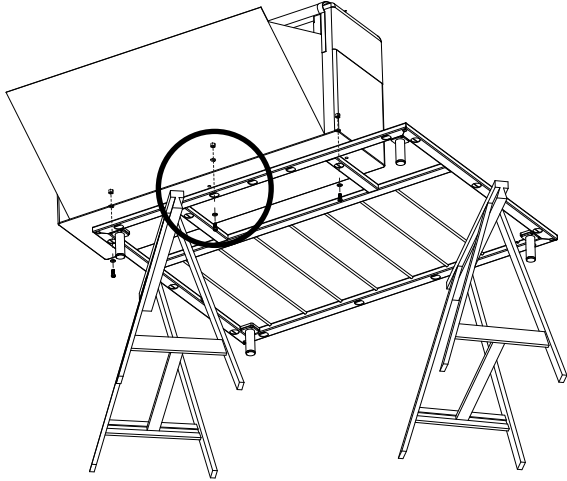

WAL155

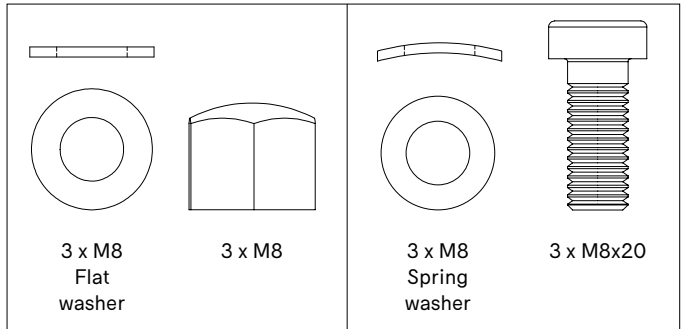

Tighten the bolts!

6.

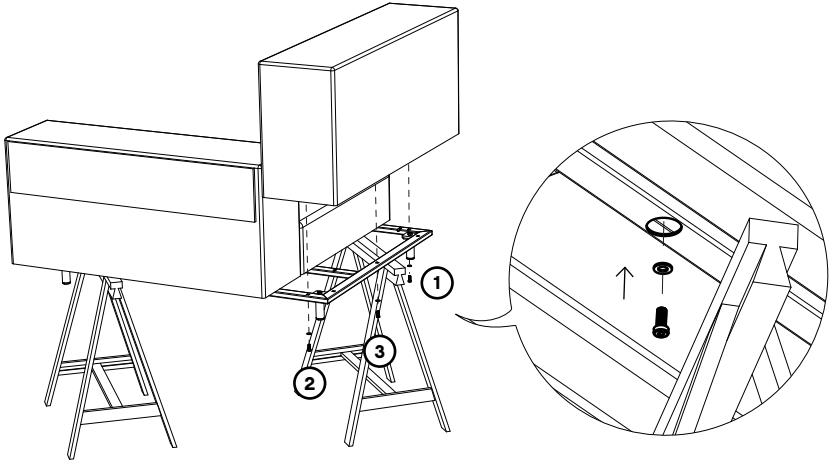

Tip: First position the bolt in the front, then the one in the back and finally the center bolt.

Tighten all bolts!

WAL155

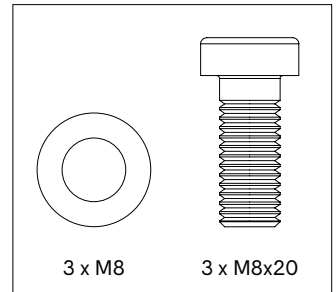

7.

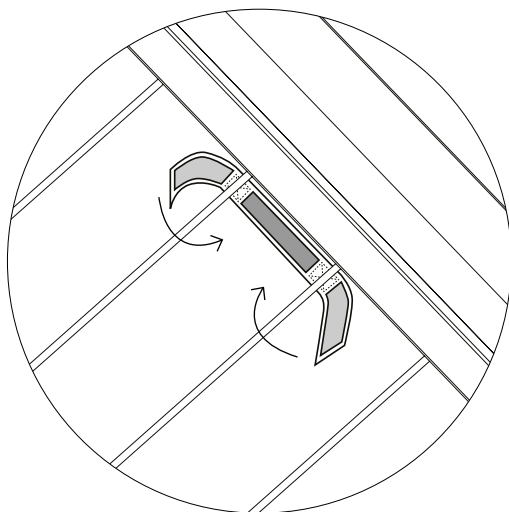
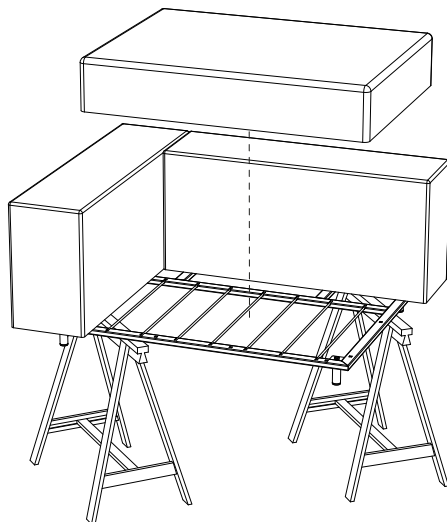

**Fix the seating cushion to the frame attaching the
Velcro straps to the rods**

Remove the trestles

Corner seat 80 cm wide seating

1.

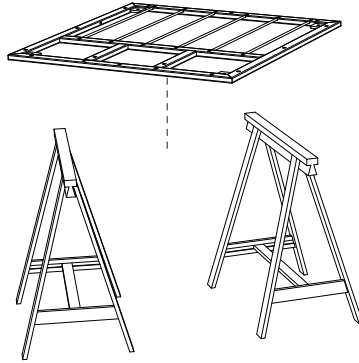
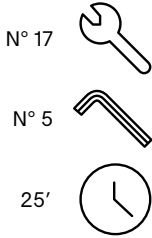

Place the frame on two trestles

2.

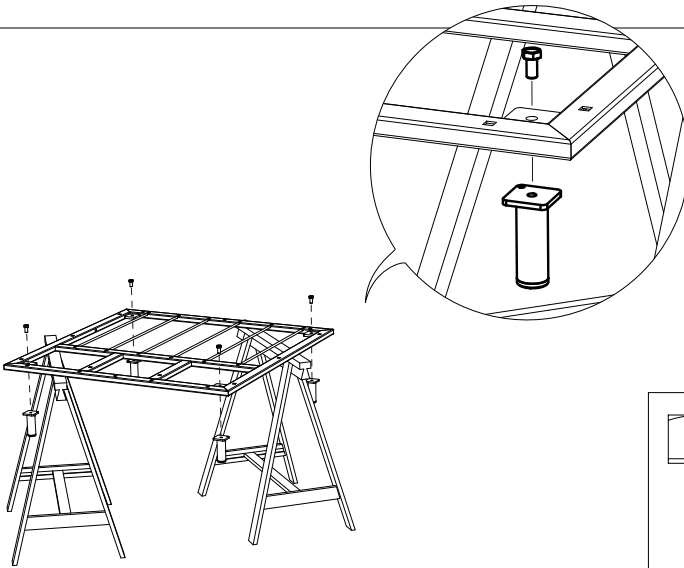

Tighten all bolts!

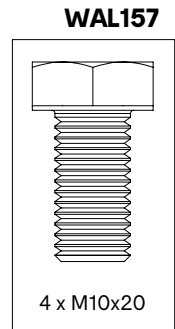

3.

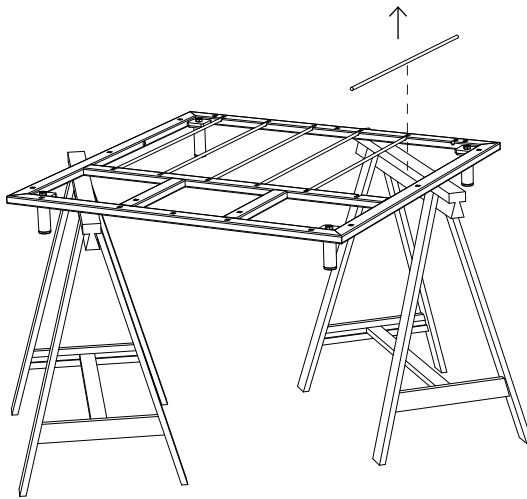

**Remove the rod on the side where you want to fit
the armrest (left or right)**

4.

Choose if you want a left or right corner seat

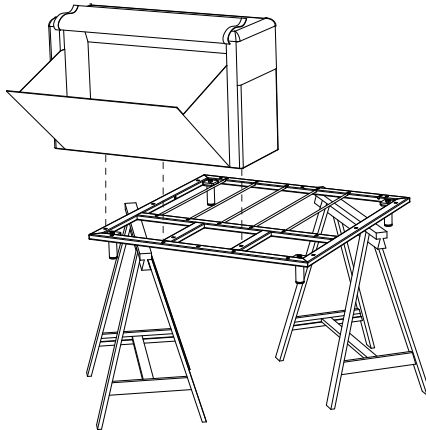
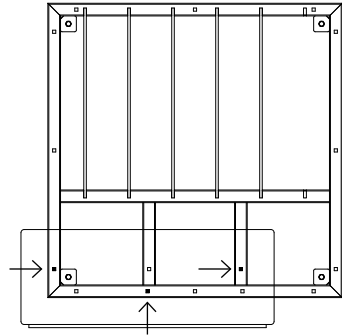
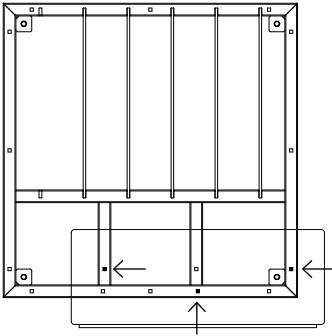
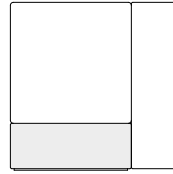
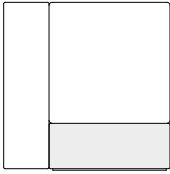

Position the backrest on of the back of the frame
(the side with no rods)

5.

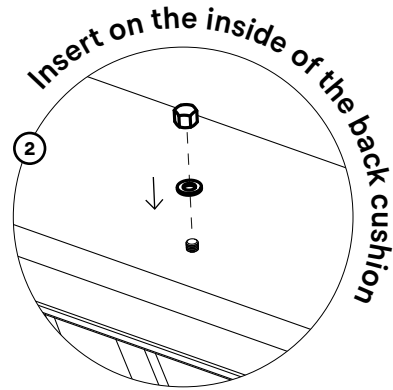
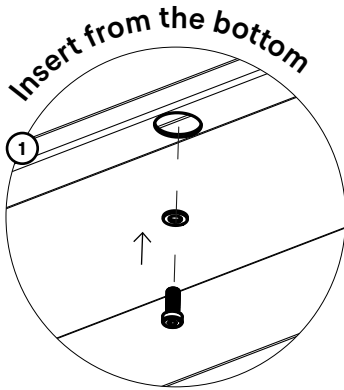
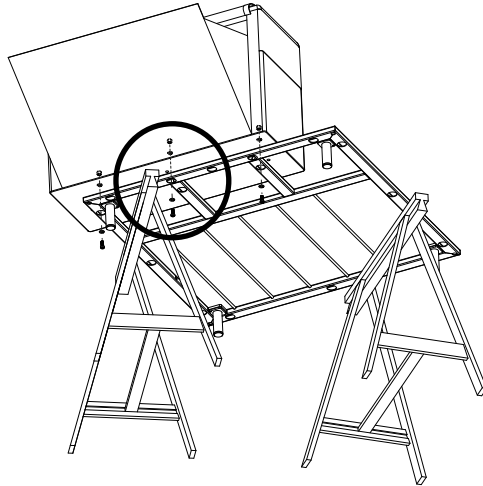

WAL155

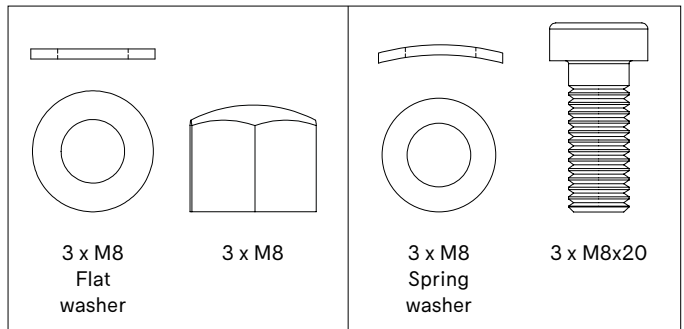

Tighten the bolts!

6.

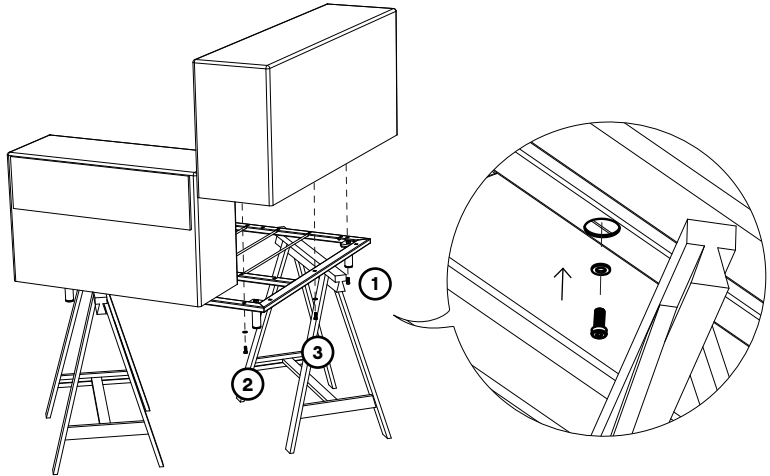

Tip: First position the bolt in the front, then the one in the back and finally the center bolt.

Tighten all bolts!

WAL155

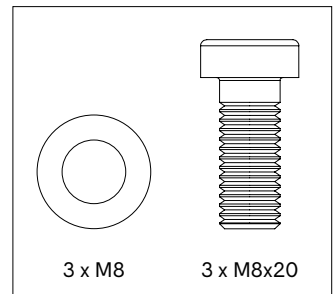

7.

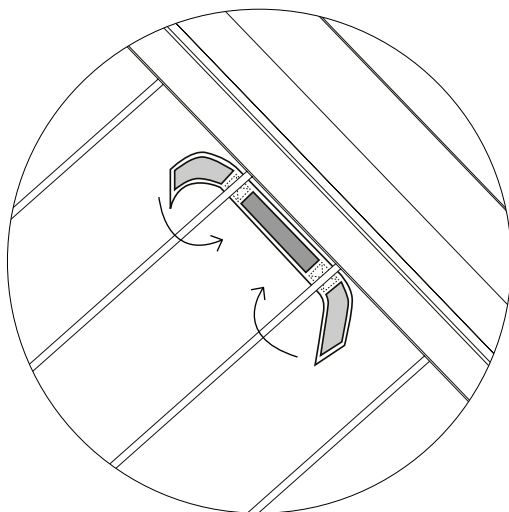
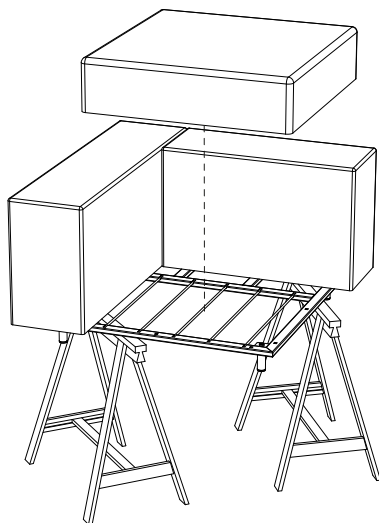

**Fix the seating cushion to the frame attaching the
Velcro straps to the rods**

Remove the trestles

Middle seat 110 cm wide seating

1.

N° 17



N° 5



20'

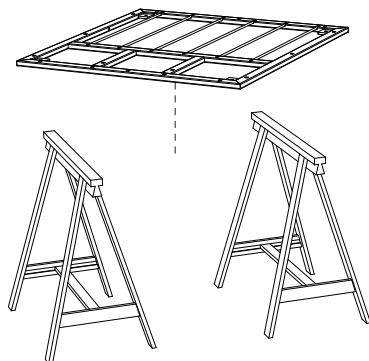

Place the frame on two trestles

2.

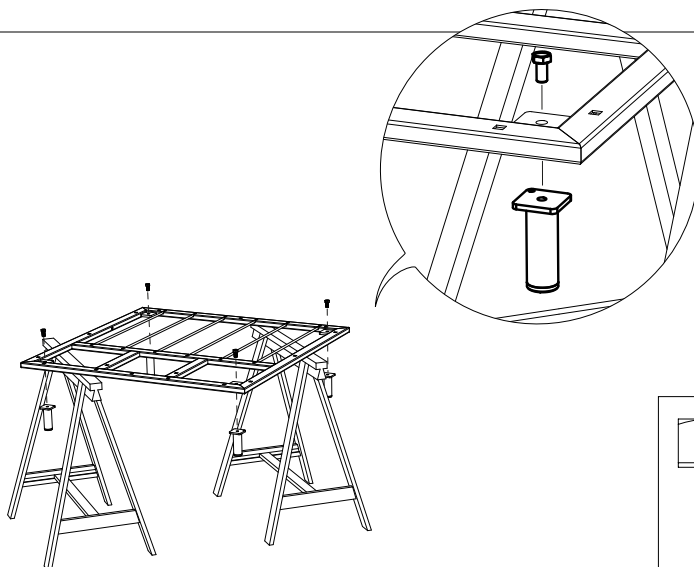

Tighten all bolts!

WAL157

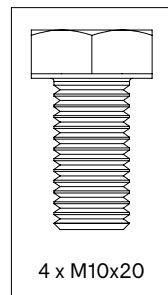

3.

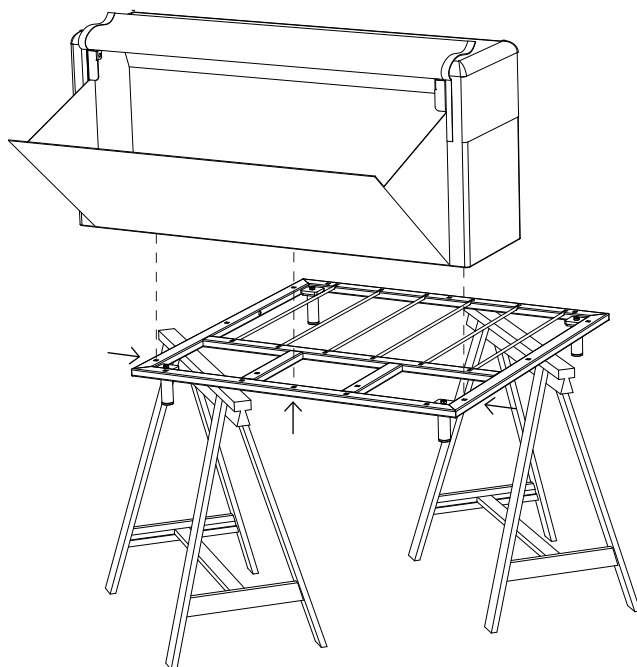

Position the backrest in the middle of the back of the frame (the side with no rods)

4.

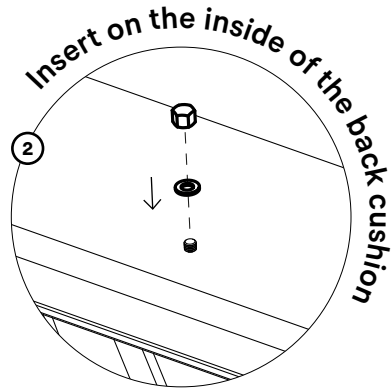
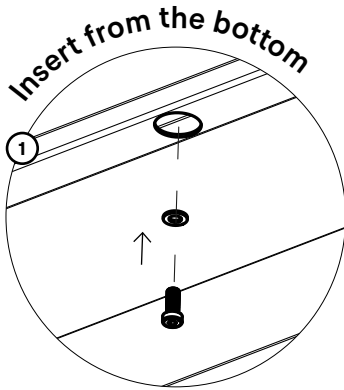
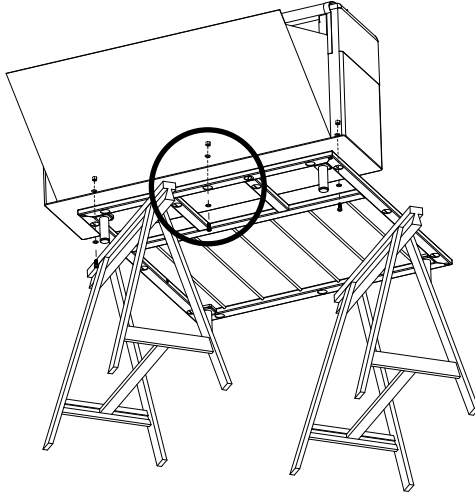

WAL155

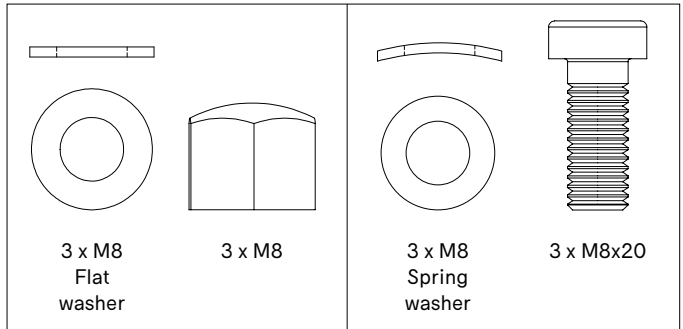

Tighten the bolts!

5.

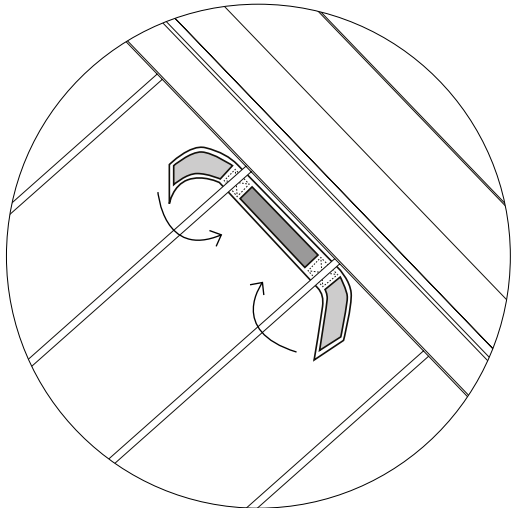
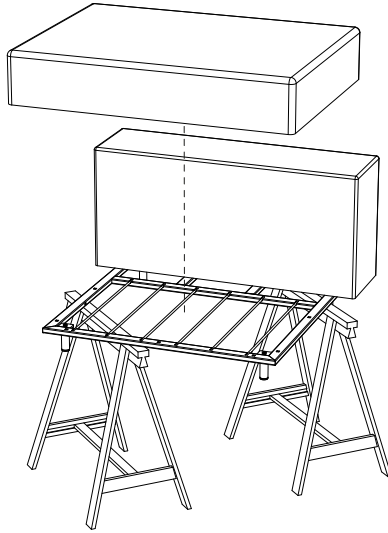

**Fix the seating cushion to the frame attaching the
Velcro straps to the rods**

Remove the trestles

Middle seat 80 cm wide seating

1.

N° 17



N° 5



20'

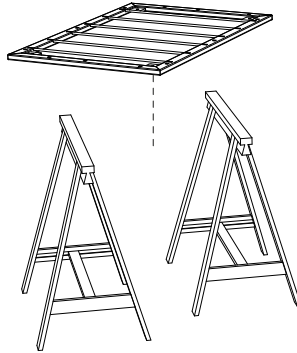

Place the frame on two trestles

2.

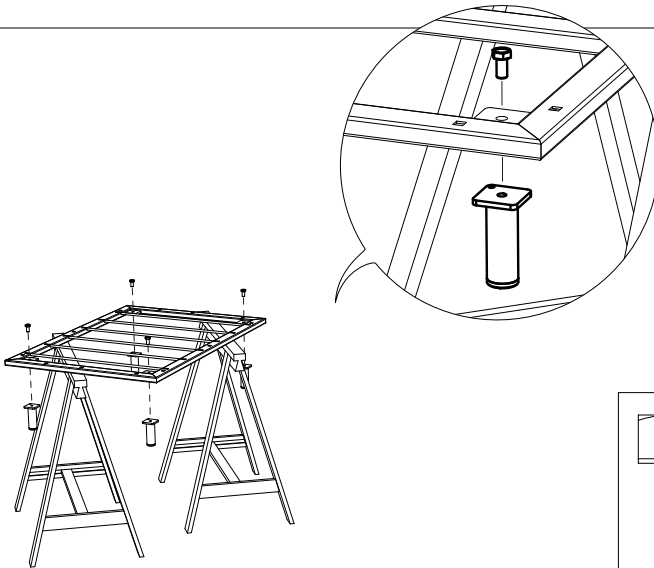

Tighten all bolts!

WAL157

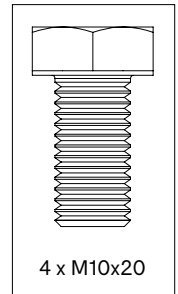

4 x M10x20



3.

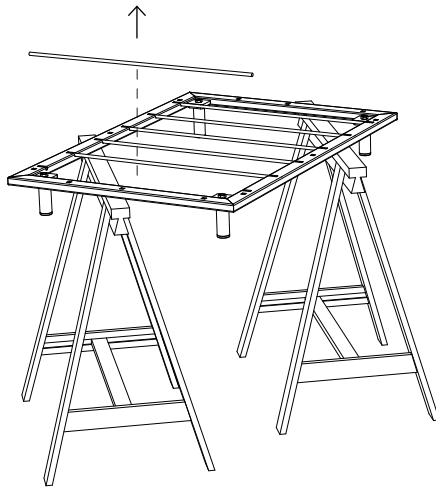

Remove the rod on one side of the frame

4.

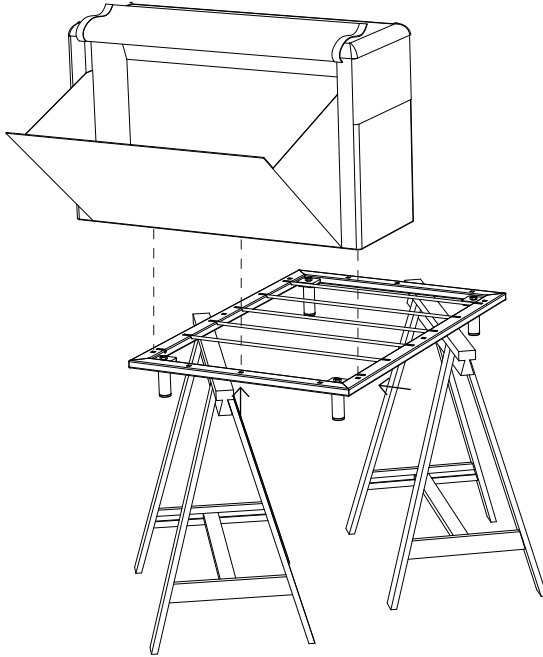

**Position the backrest in the middle of the back of
the frame (the side with no rod)**

5.

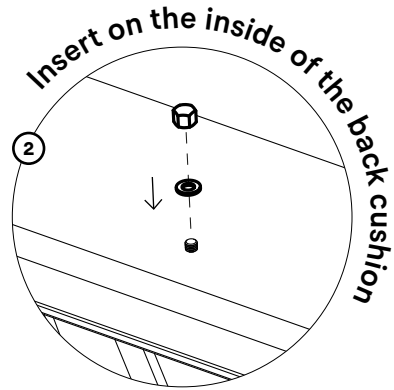
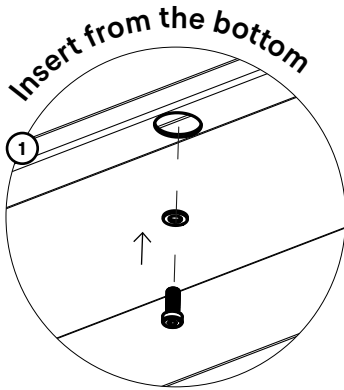
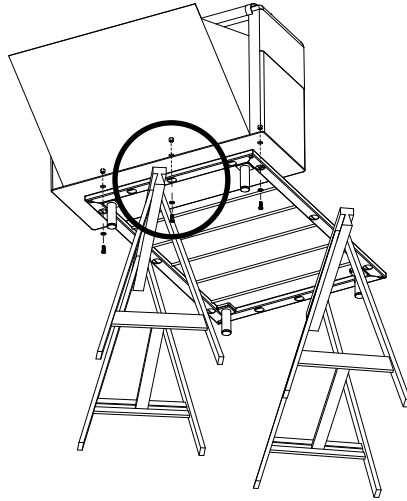

WAL155

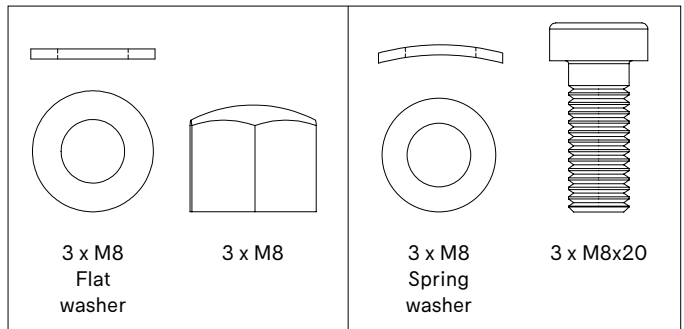

Tighten the bolts!

6.

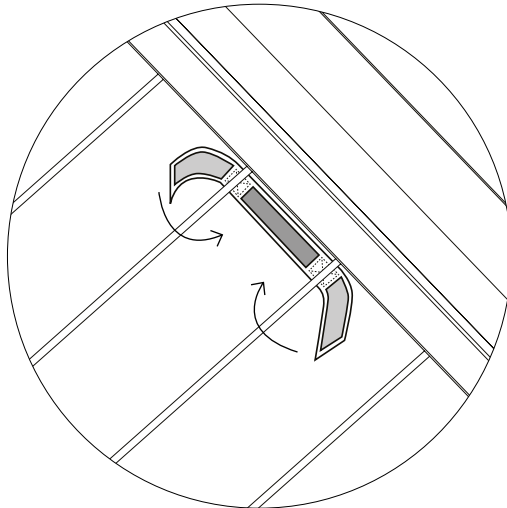
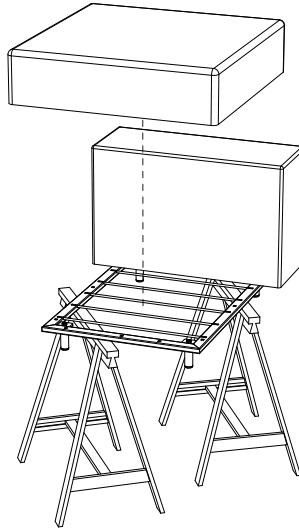

**Fix the seating cushion to the frame attaching the
Velcro straps to the rods**

Remove the trestles

Seat with side table 110

1.

N° 17



N° 5



25'

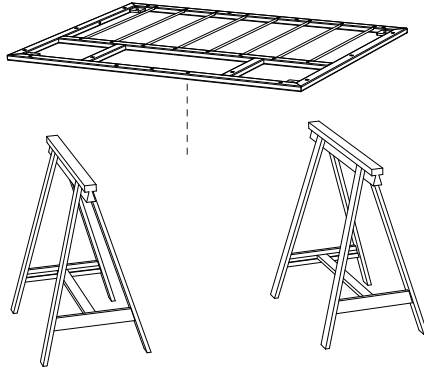

Place the frame on two trestles

2.

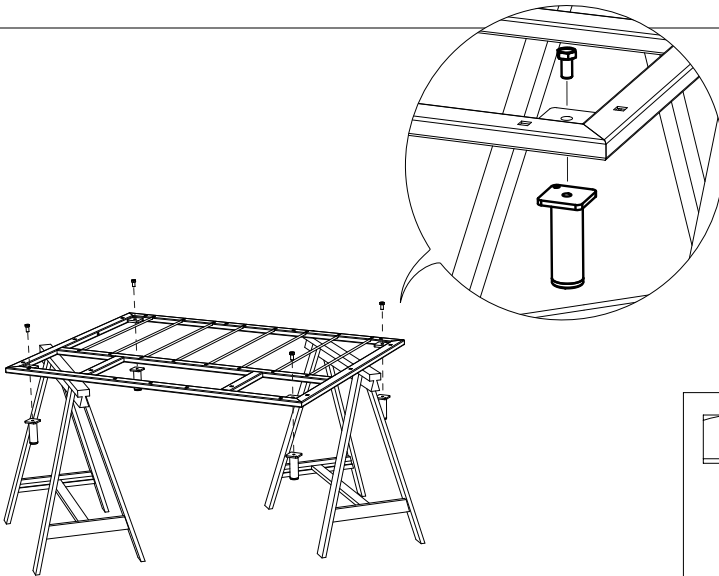

Tighten all bolts!

WAL157

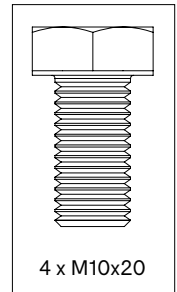

3.

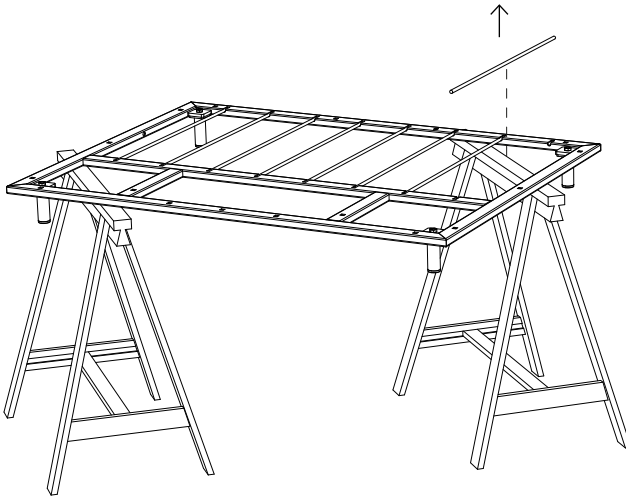

**Remove the rod on the side where you want to fit
the side table (left or right)**

4.

Choose if you want the side table on the left or right

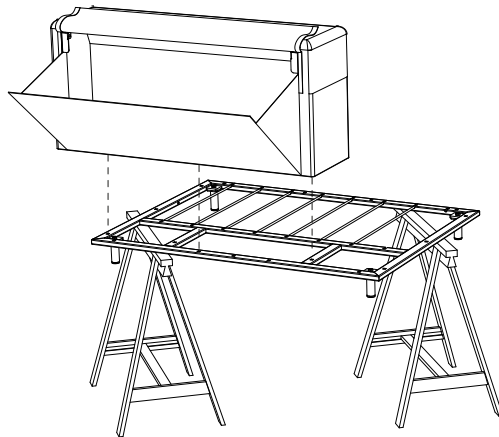
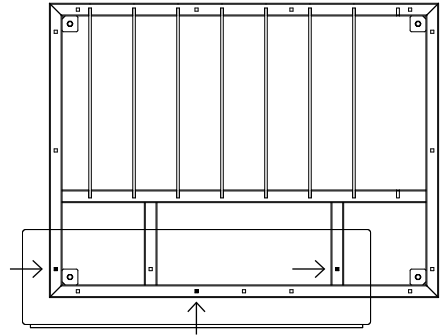
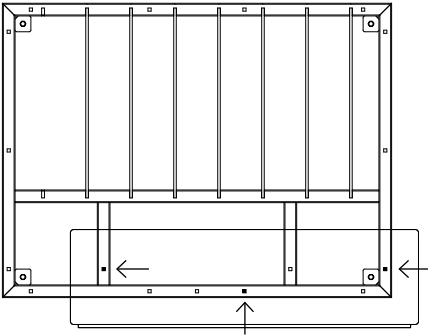
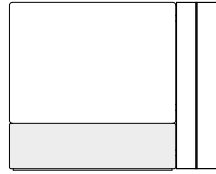

Position the backrest on of the back of the frame
(the side with no rods)

5.

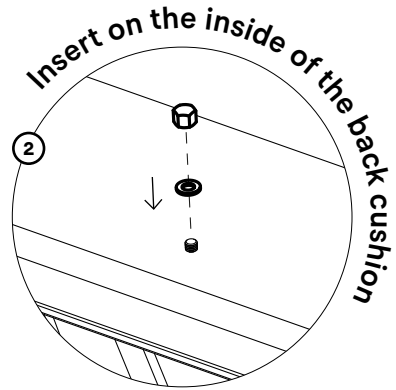
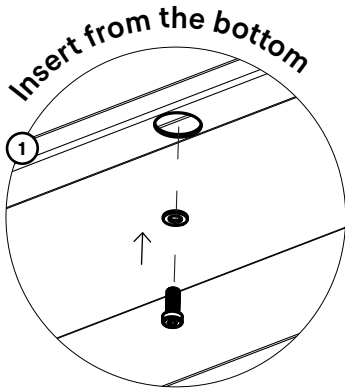
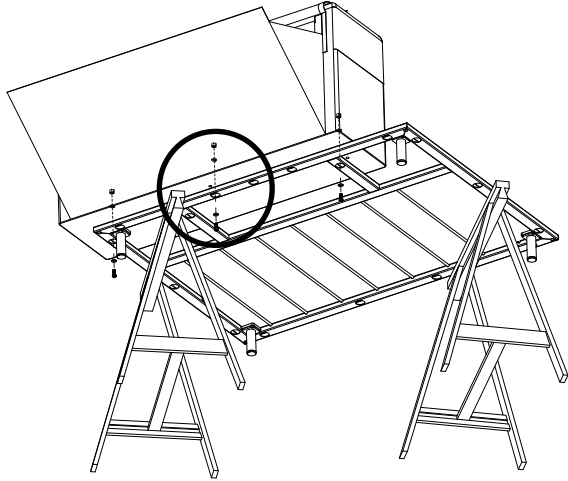

WAL155

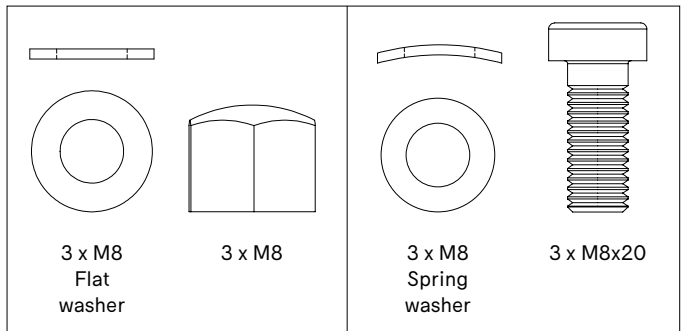

Tighten the bolts!

6.

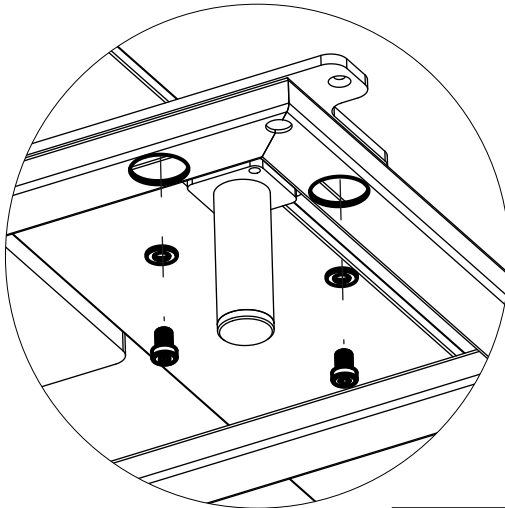
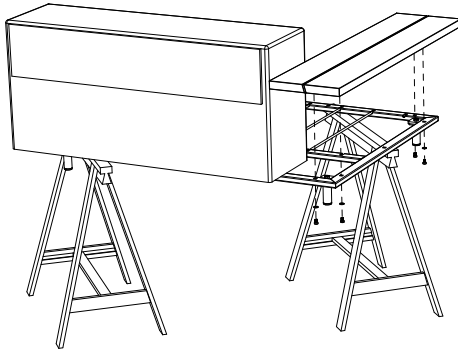

Tighten all bolts!

WAL181

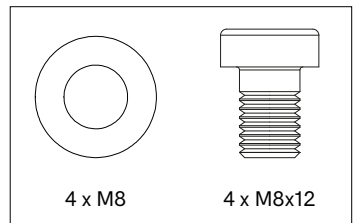

7.

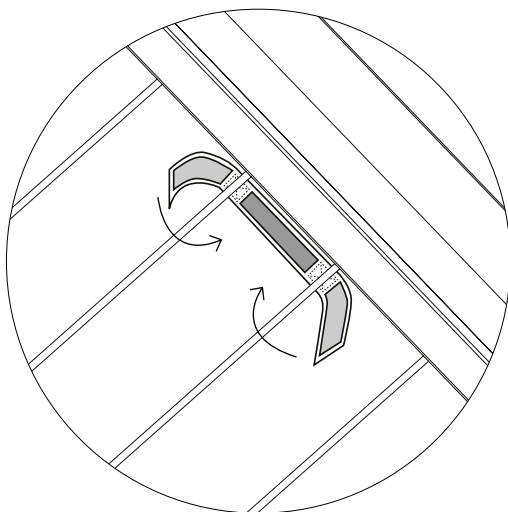
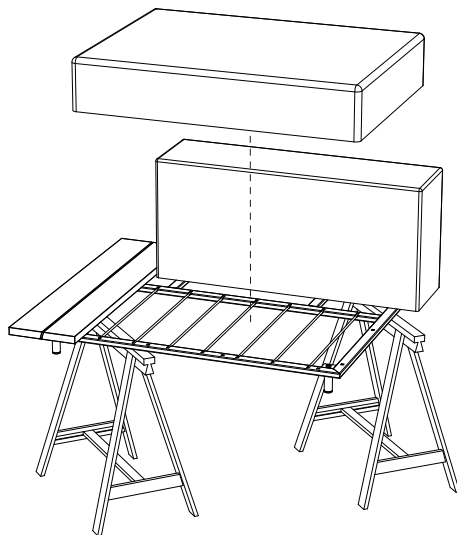

**Fix the seating cushion to the frame attaching the
Velcro straps to the rods**

Remove the trestles

Seat with side table 80

1.

N° 17



N° 5



25'

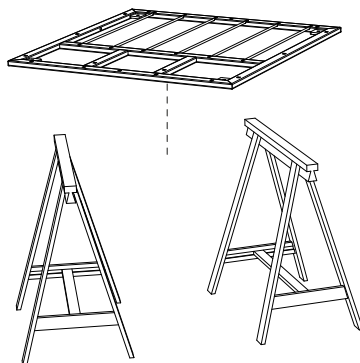

Place the frame on two trestles

2.

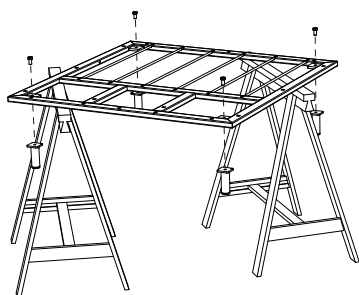
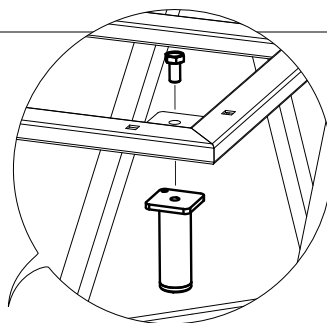

Tighten all bolts!

WAL157

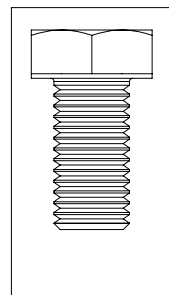

3.

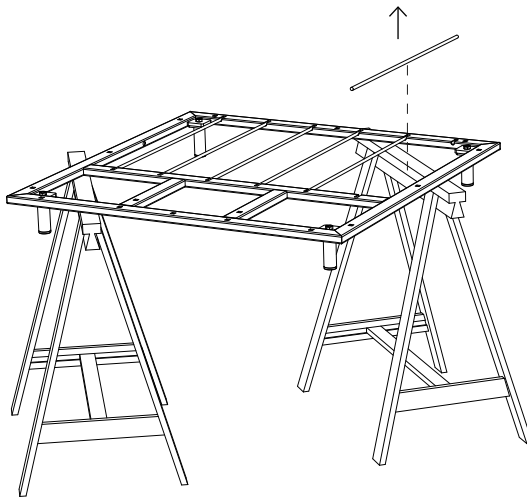

**Remove the rod on the side where you want to fit
the side table (left or right)**

4.

Choose if you want the side table on the left or right

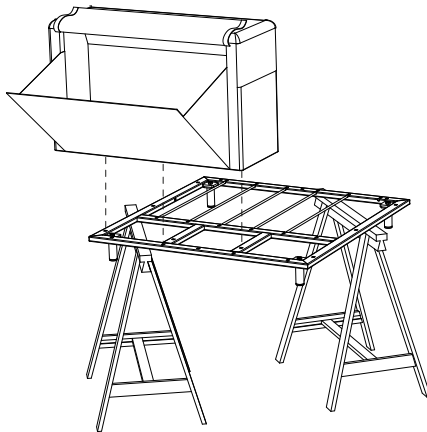
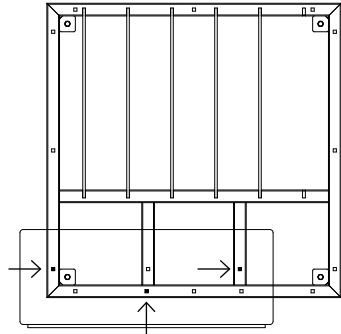
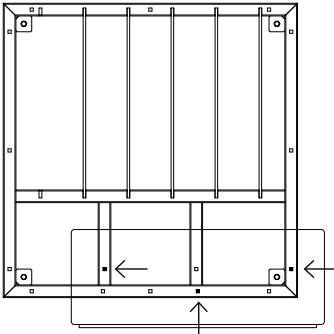
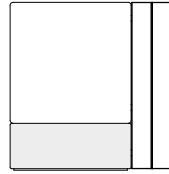
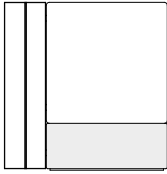

Position the backrest on of the back of the frame
(the side with no rods)

5.

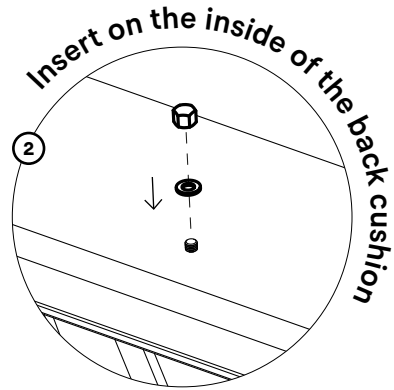
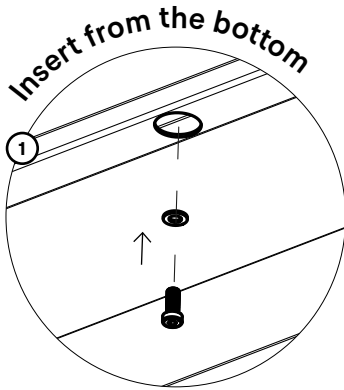
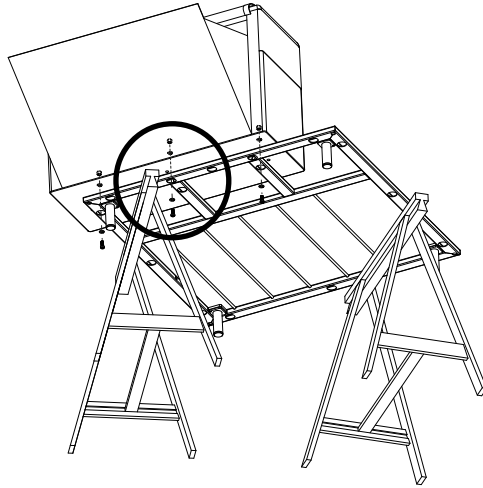

WAL155

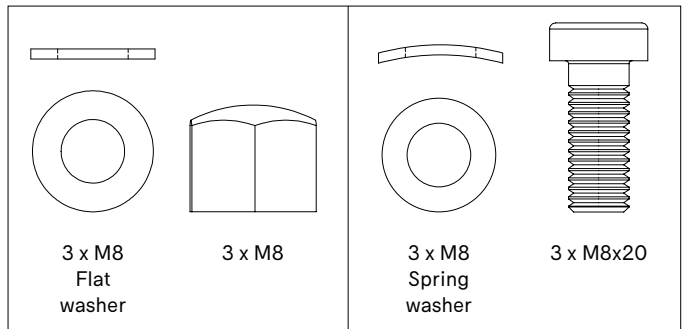

Tighten the bolts!

6.

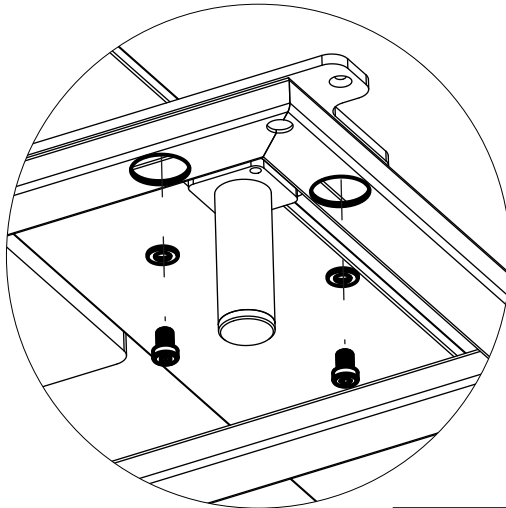
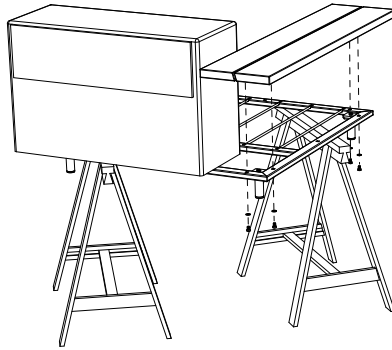

Tighten all bolts!

WAL181

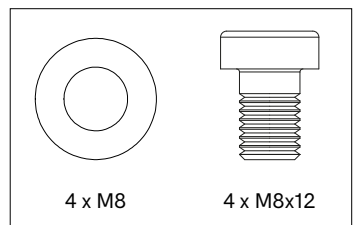

4 x M8

4 x M8x12

7.

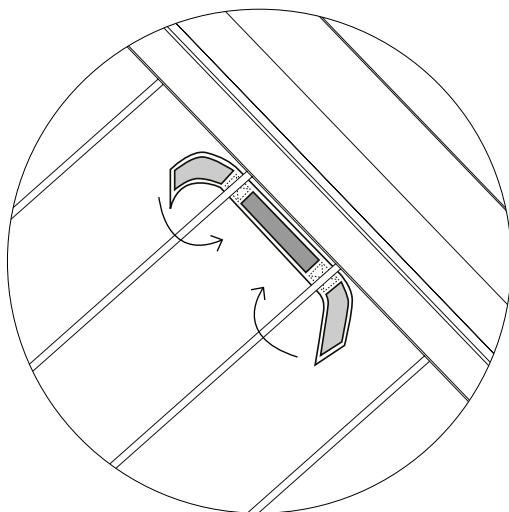
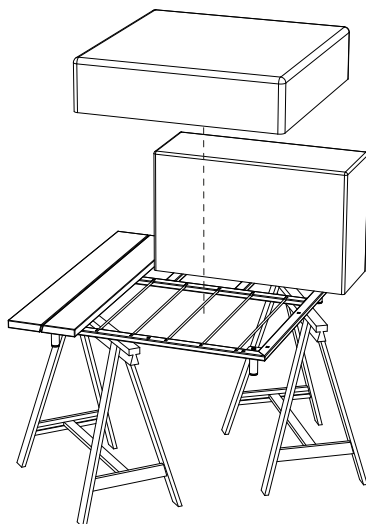

**Fix the seating cushion to the frame attaching the
Velcro straps to the rods**

Remove the trestles

Corner seat with side table 110

1.

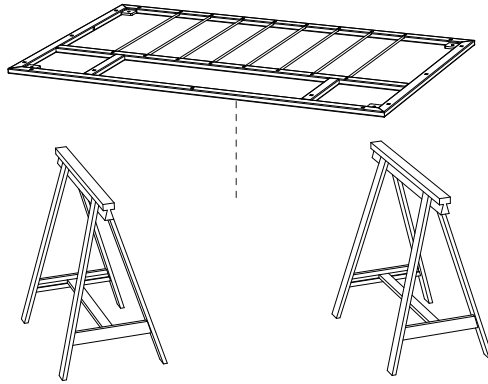

N° 17



N° 5



30'



Place the frame on two trestles

2.

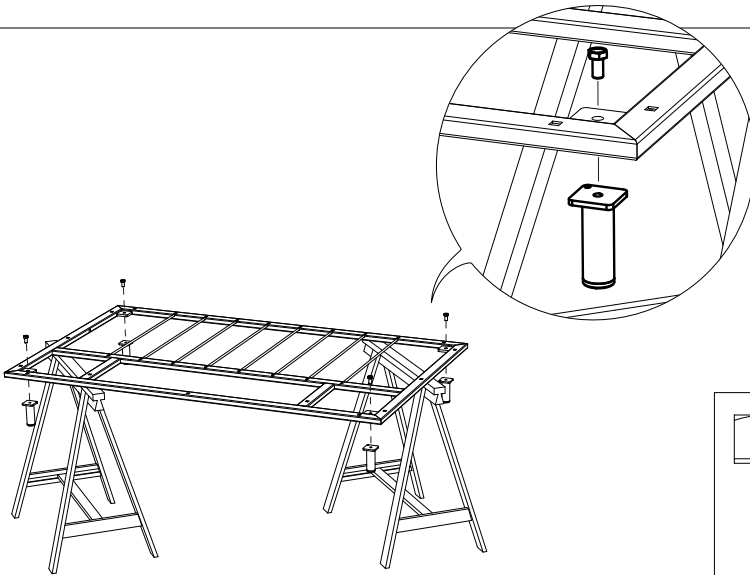

Tighten all bolts!

WAL157

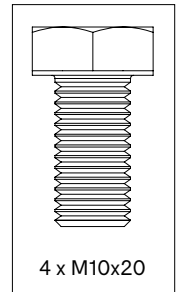

3.

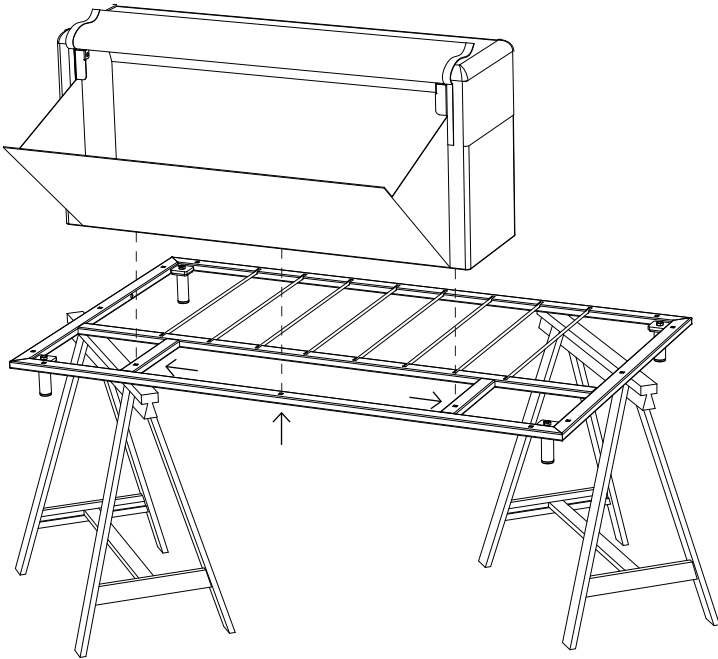

Position the backrest in the middle of the back of the frame (the side with no rods)

4.

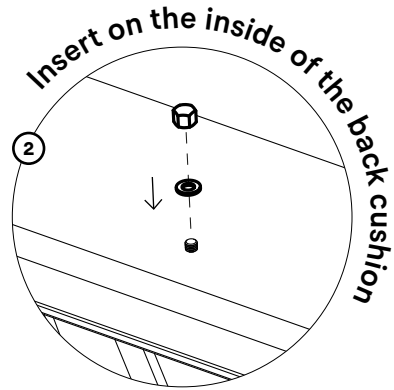
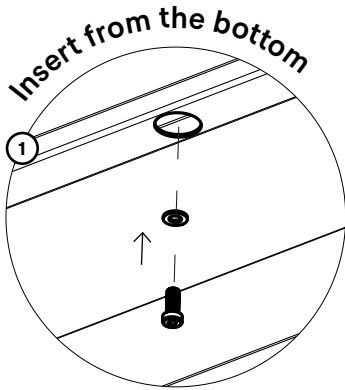
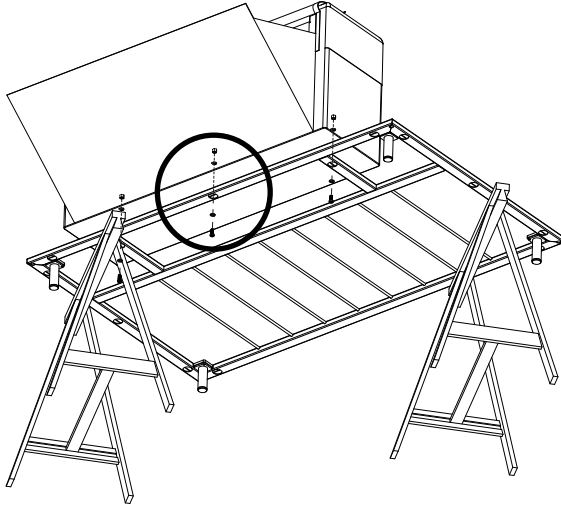

WAL155

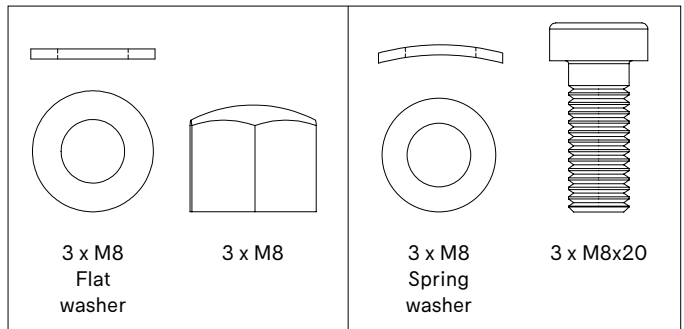

Tighten the bolts!

5.

Choose if you want a left or right corner seat

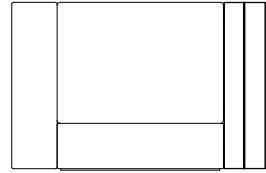
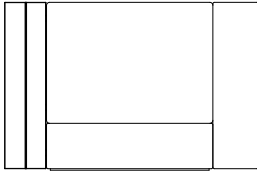

Attach the armrest to the frame

Tip: First position the bolt in the front, then the one in the back and finally the center bolt.

Tighten the bolts!

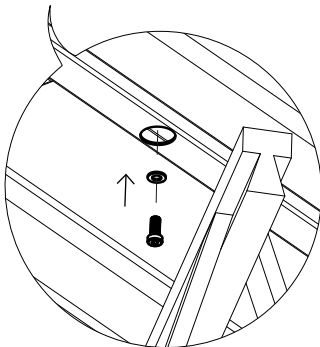
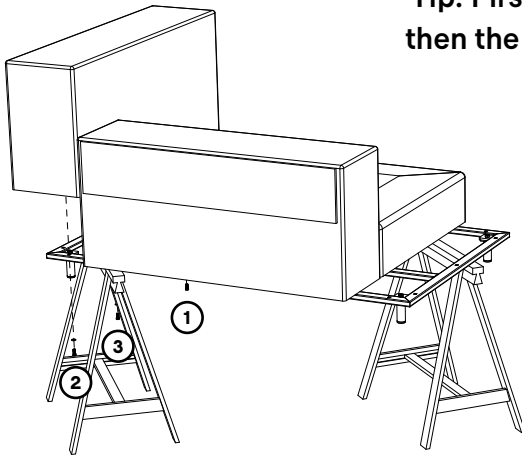

WAL155

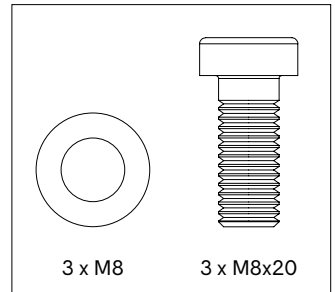

6.

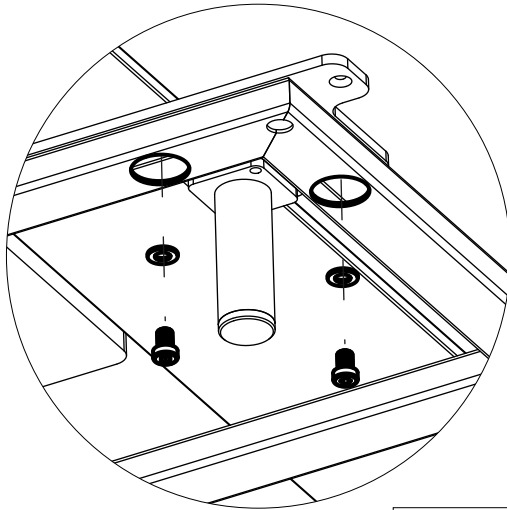
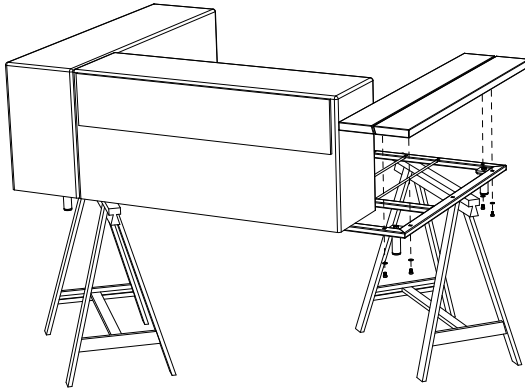

Tighten all bolts!

WAL181

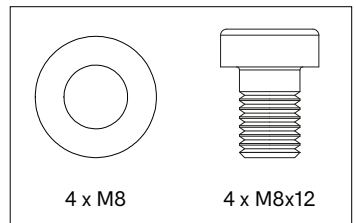

7.

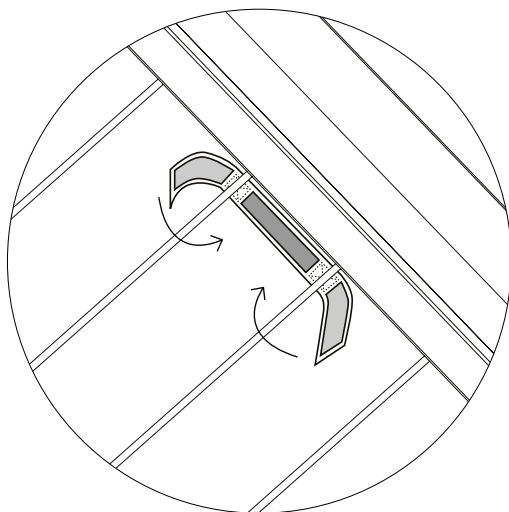
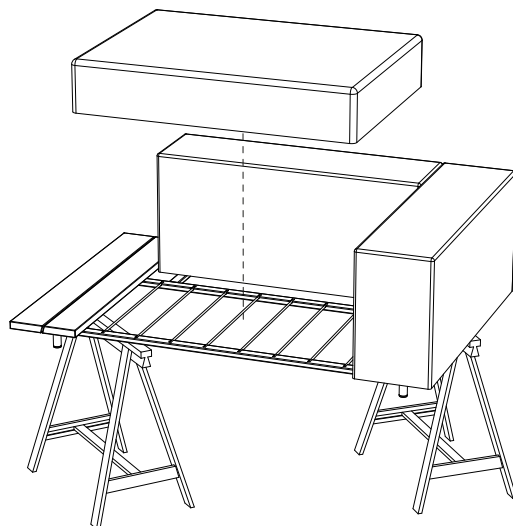

**Fix the seating cushion to the frame attaching the
Velcro straps to the rods**

Remove the trestles

Corner seat with side table 80

1.

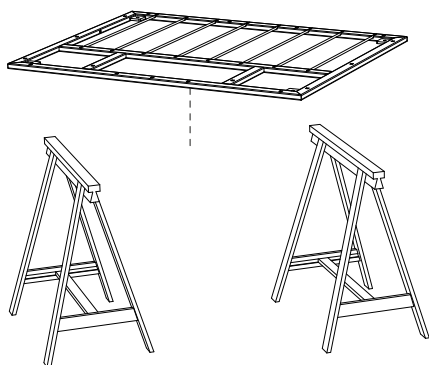

N° 17



N° 5



30'



Place the frame on two trestles

2.

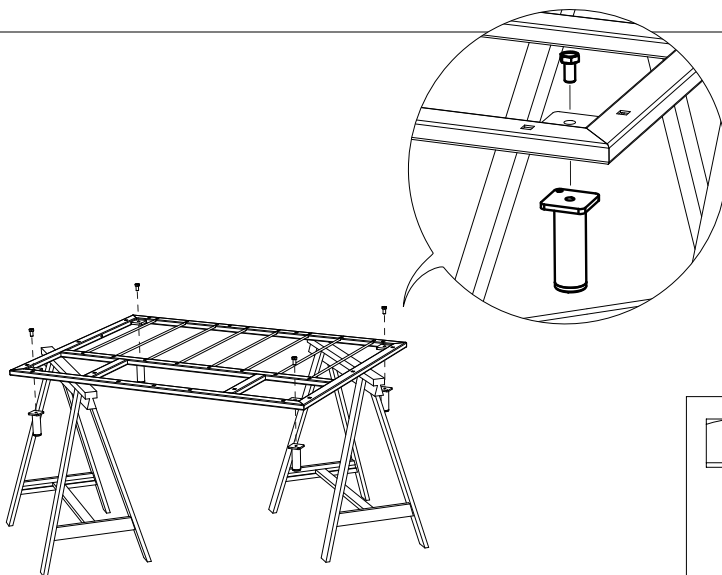

Tighten all bolts!

WAL157

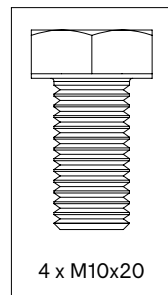

4 x M10x20

3.

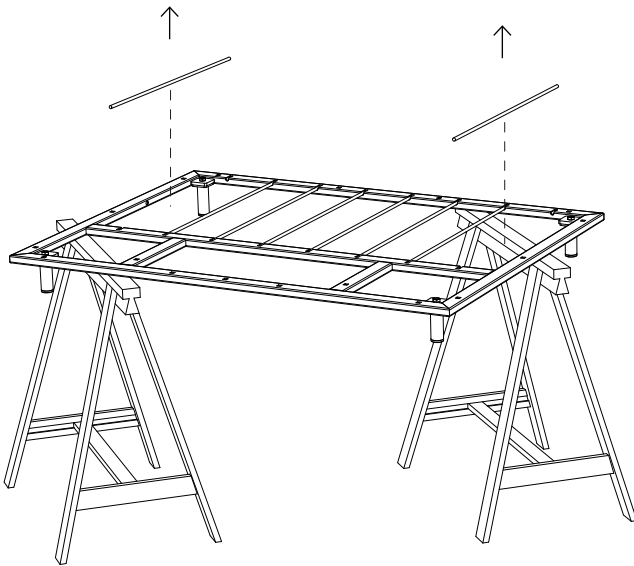

Remove the rods on both sides

4.

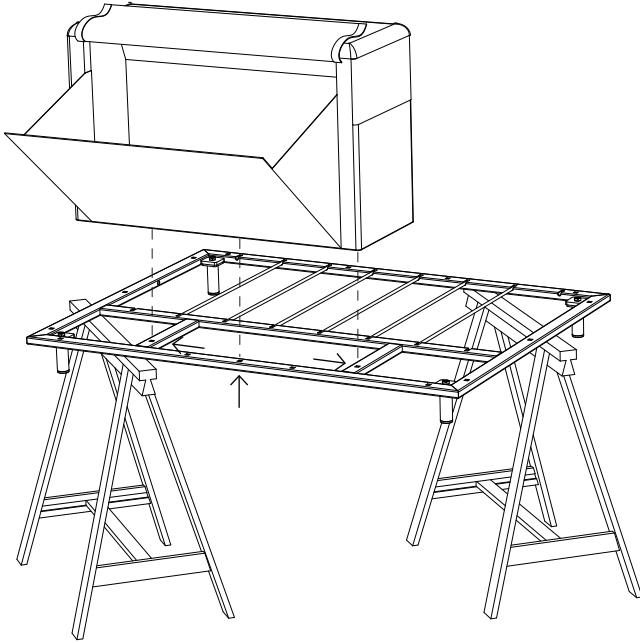

Position the backrest in the middle of the back of the frame (the side with no rods)

5.

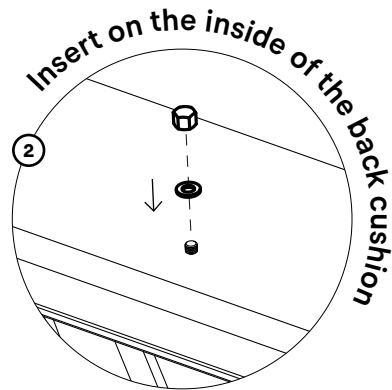
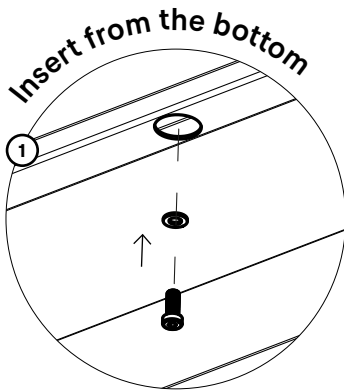
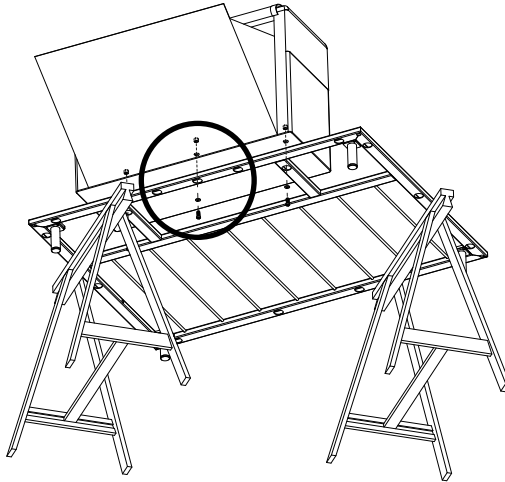

WAL155

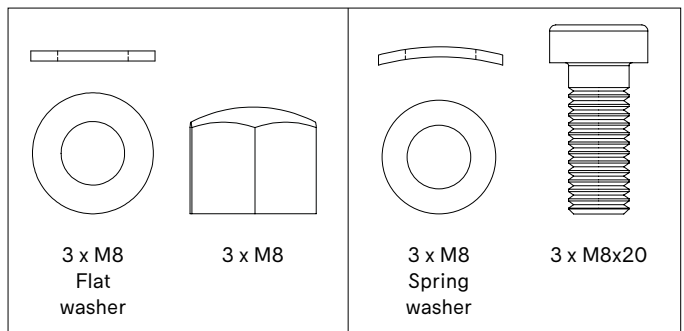

Tighten the bolts!

6.

Choose if you want a left or right corner seat

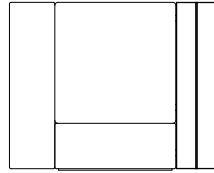
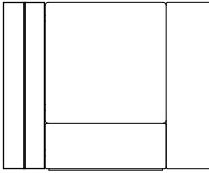

Attach the armrest to the frame

Tip: First position the bolt in the front, then the one in the back and finally the center bolt.

Tighten the bolts!

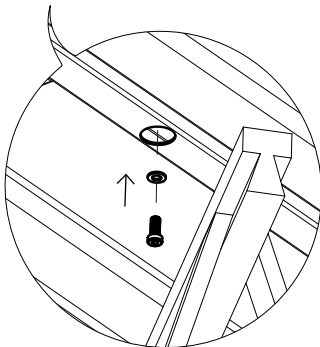
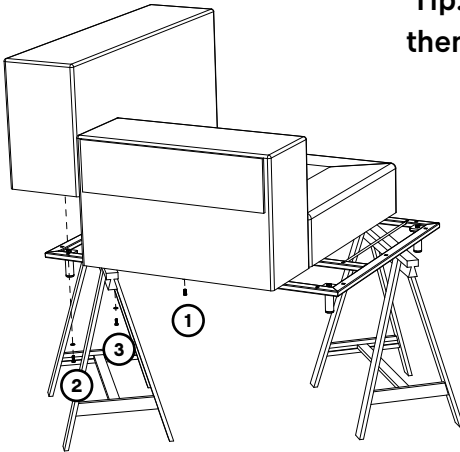

WAL155

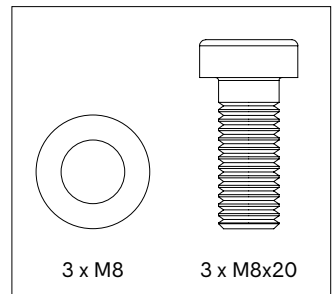

7.

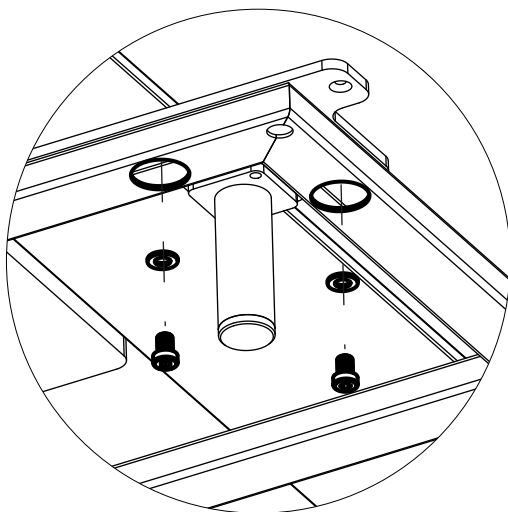
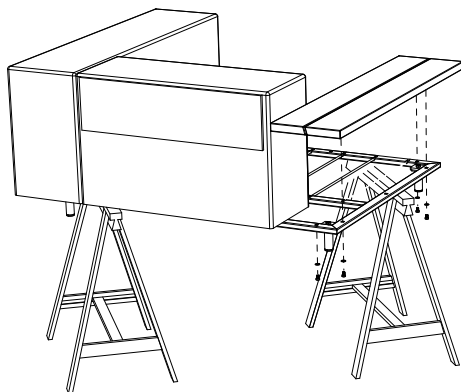

Tighten all bolts!

WAL181

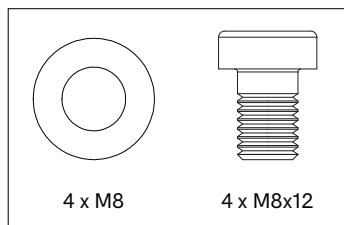

8.

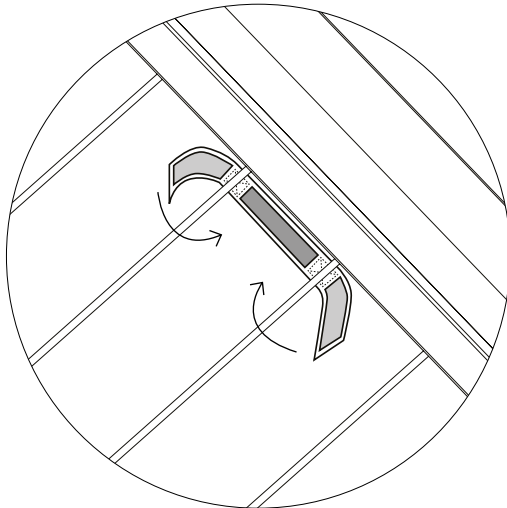
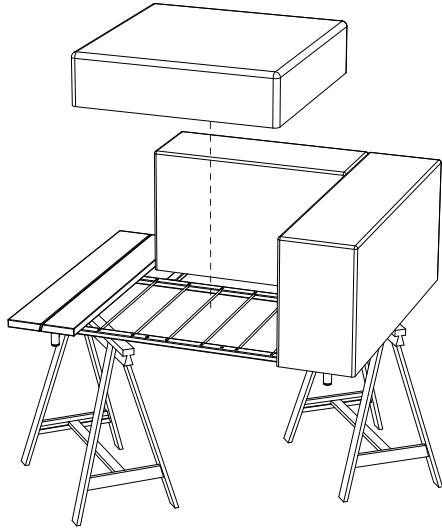

**Fix the seating cushion to the frame attaching the
Velcro straps to the rods**

Remove the trestles

Seat with 2 side tables 110

1.

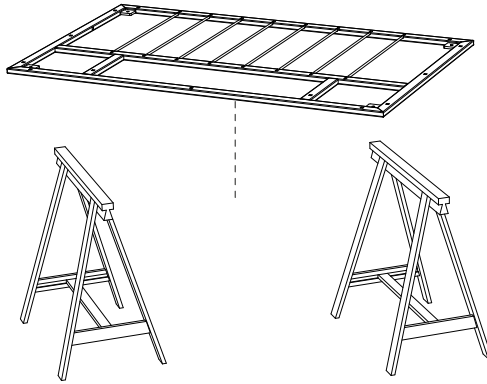

N° 17



N° 5



30'



Place the frame on two trestles

2.

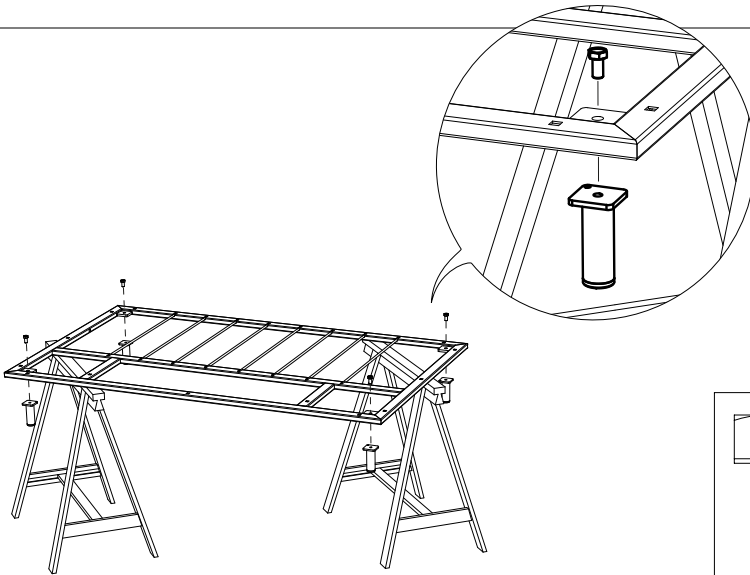

Tighten all bolts!

WAL157

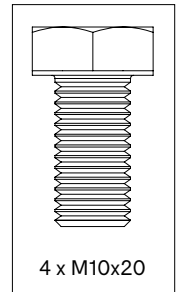

4 x M10x20



3.

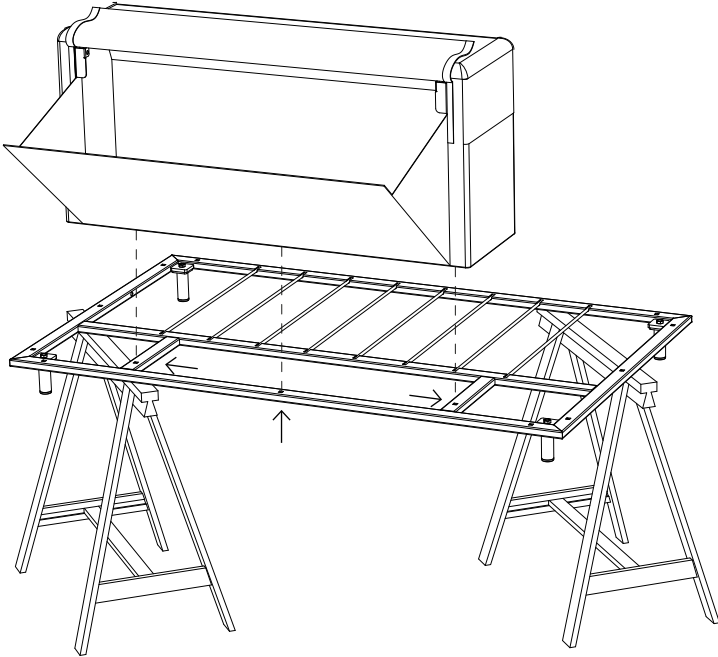

Position the backrest in the middle of the back of the frame (the side with no rods)

4.

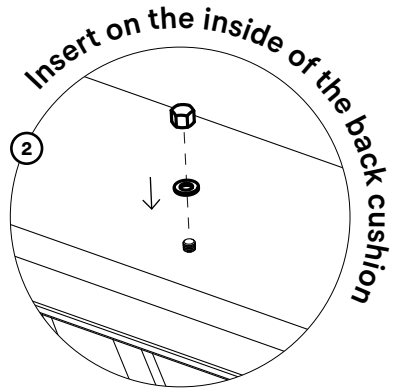
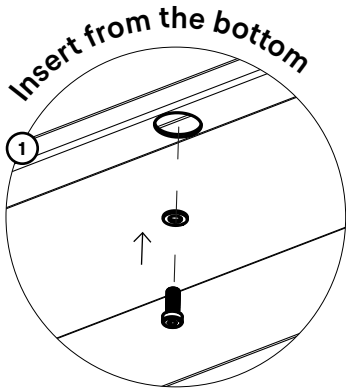
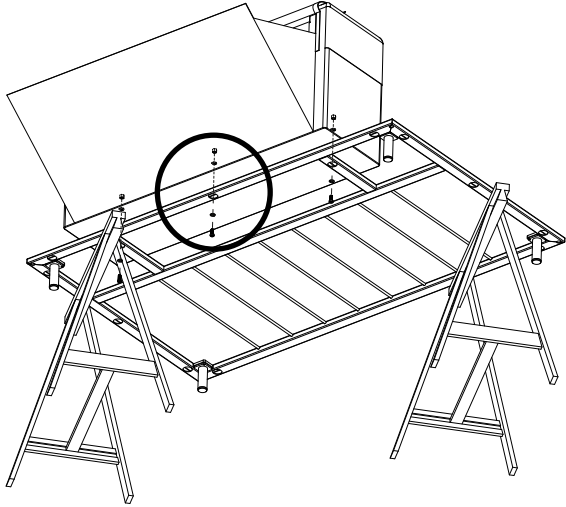

WAL155

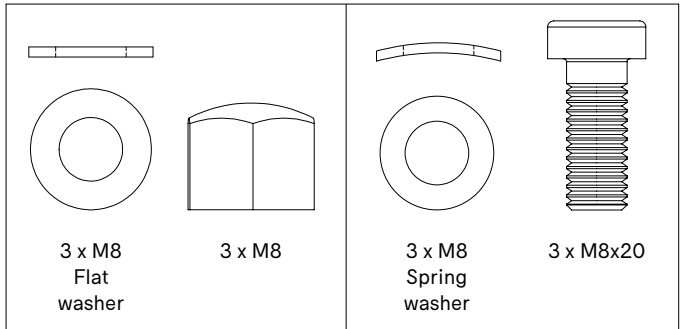

Tighten the bolts!

5.

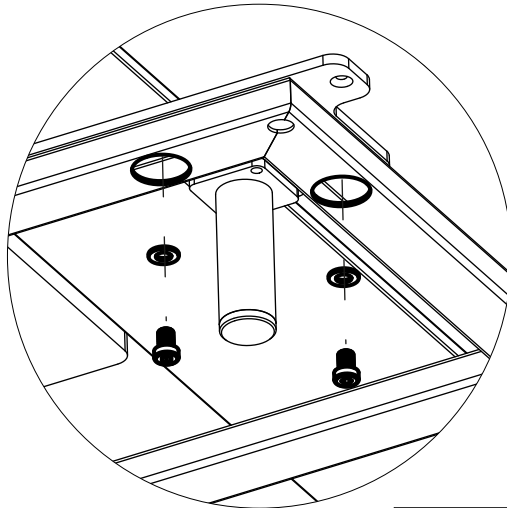
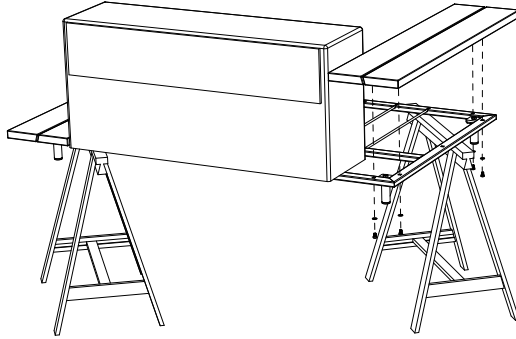

WAL181
per side table

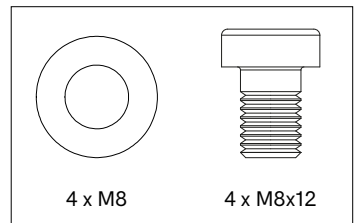

Attach both side tables to the frame
Tighten all bolts!

6.

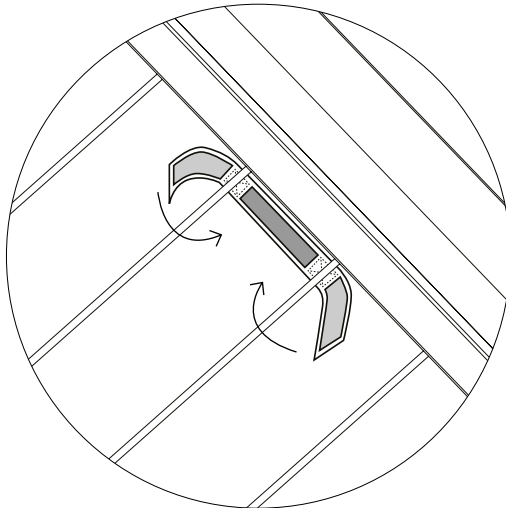
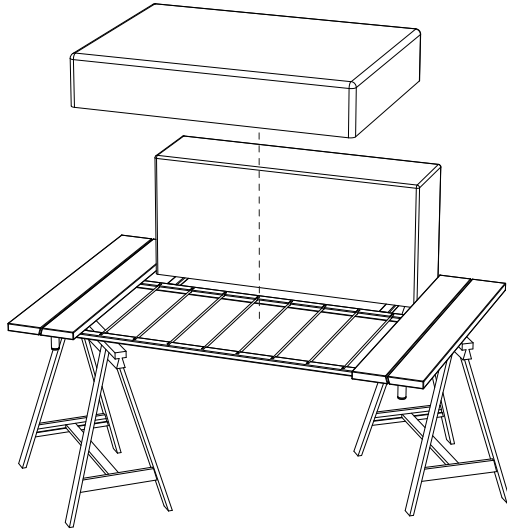

**Fix the seating cushion to the frame attaching the
Velcro straps to the rods**

Remove the trestles

Seat with 2 side tables 80

1.

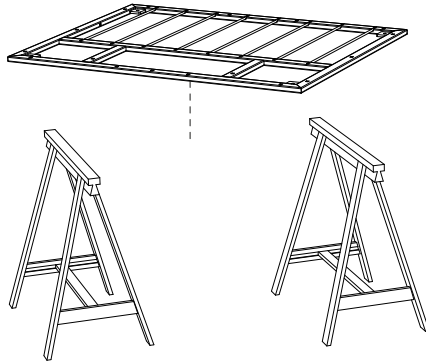

N° 17



N° 5



30'



Place the frame on two trestles

2.

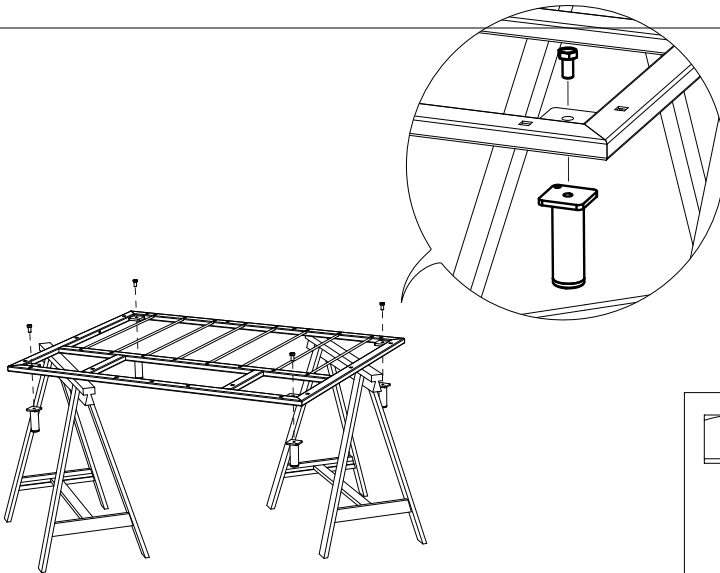

Tighten all bolts!

WAL157

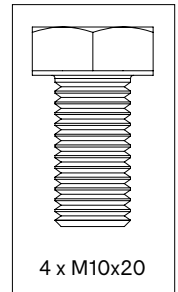

3.

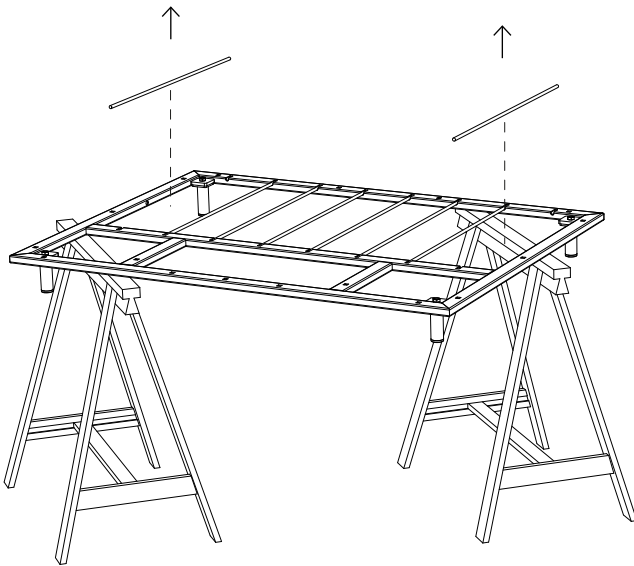

Remove the rods on both sides

4.

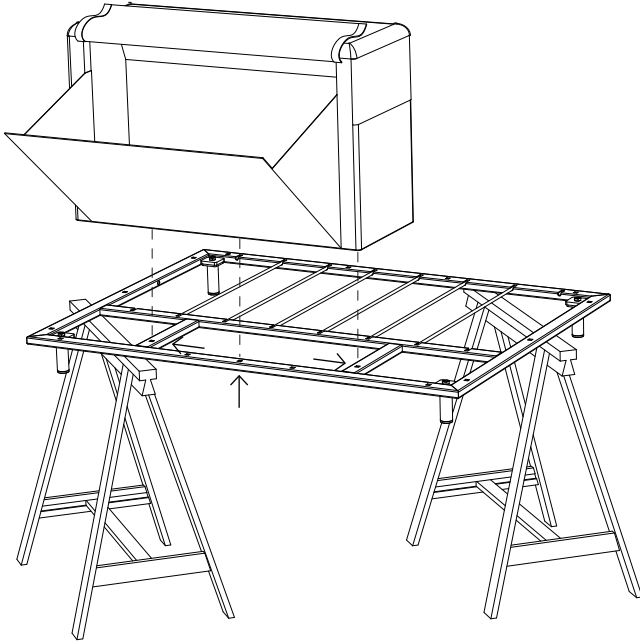

Position the backrest in the middle of the back of the frame (the side with no rods)

5.

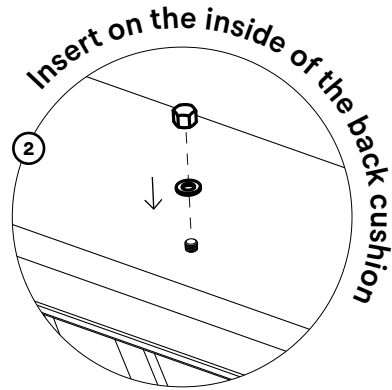
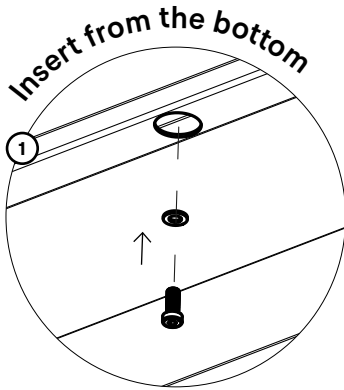
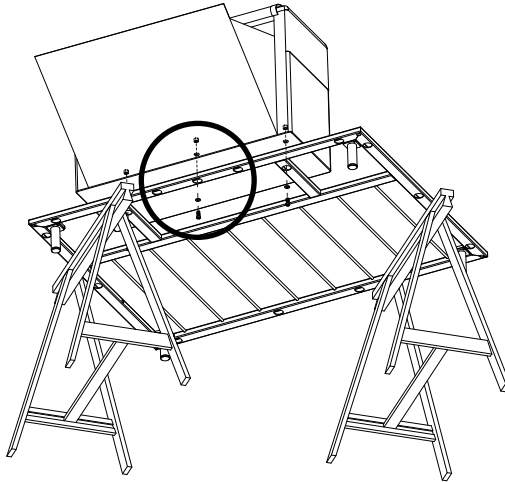

WAL155

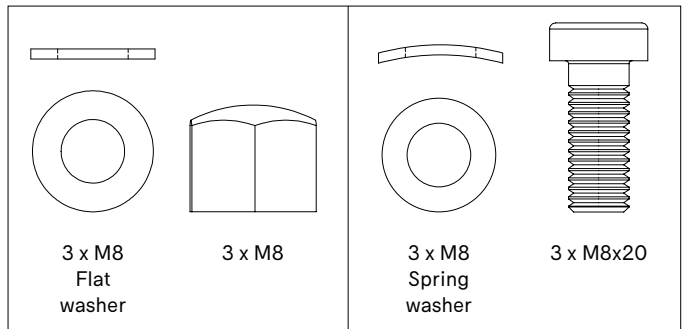

Tighten the bolts!

6.

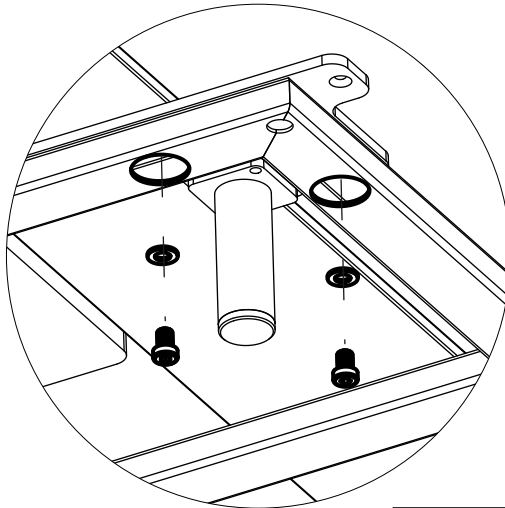
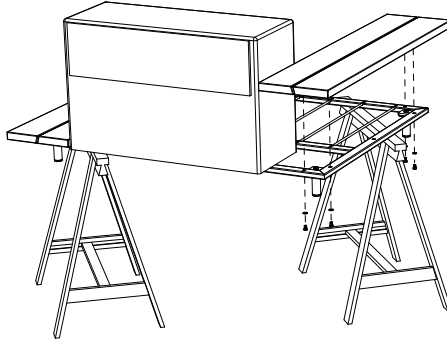

WAL181
per side table

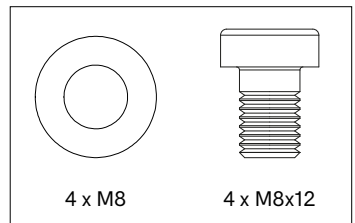

Attach both side tables to the frame
Tighten all bolts!

7.

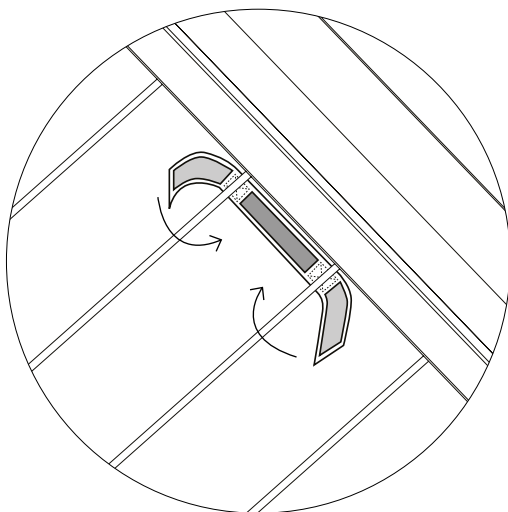
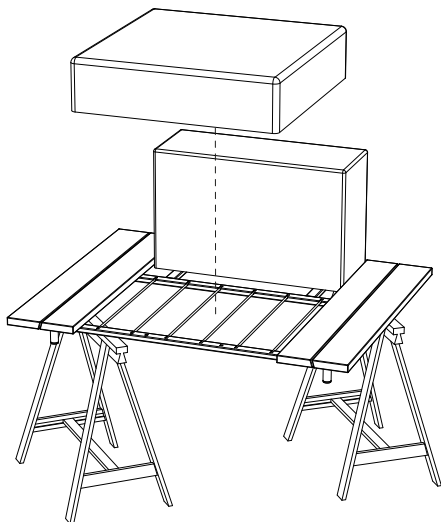

**Fix the seating cushion to the frame attaching the
Velcro straps to the rods**

Remove the trestles

Optional: blanket & comfort cushion

1.

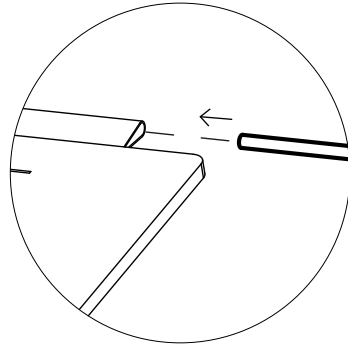
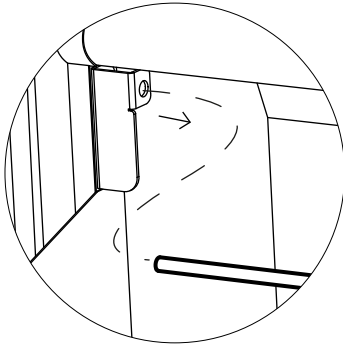
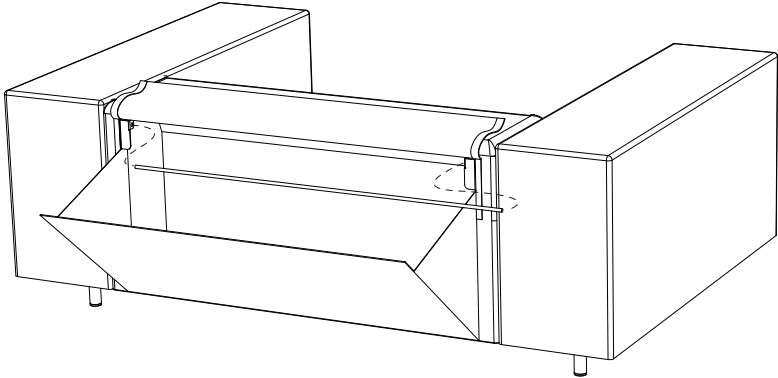

**Take the rod out of the back of the backrest
and insert it into the blanket**

2.

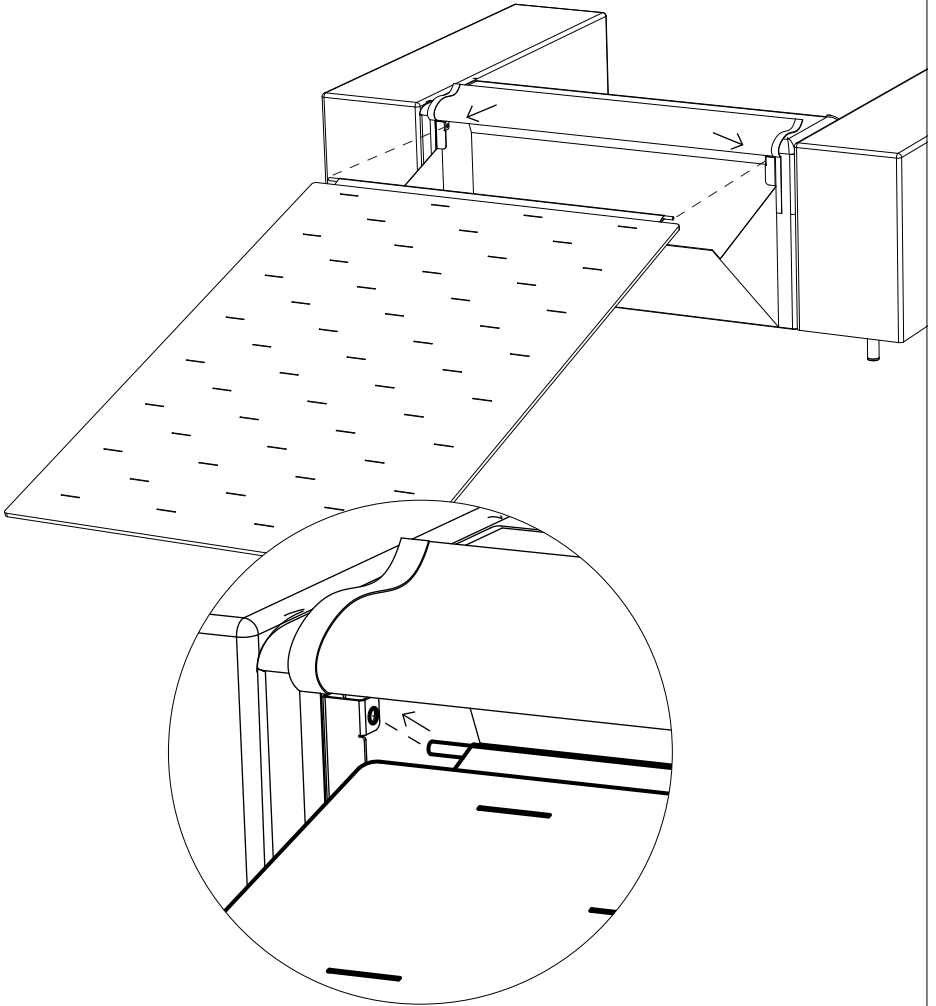

**Attach the fiberglass rod inside the blanket
in the back of the backrest**

3.



Watch the video

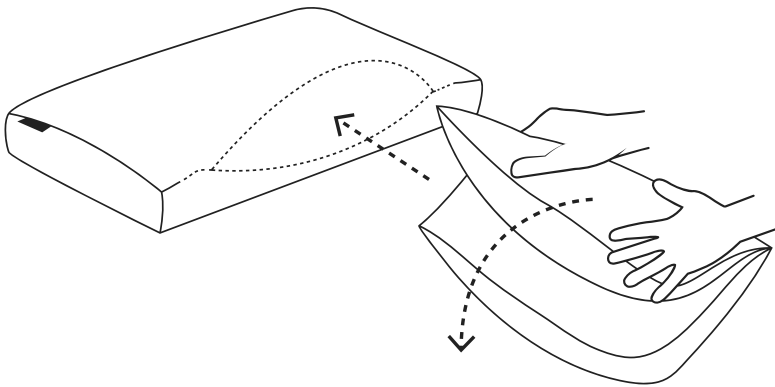

- 1. Fold the cushion when inserting it into the pillowcase**
- 2. Unfold inside the pillowcase**

Footstool

1.

N° 17



15'

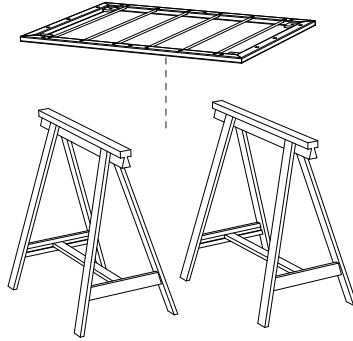

Place the frame on two trestles

2.

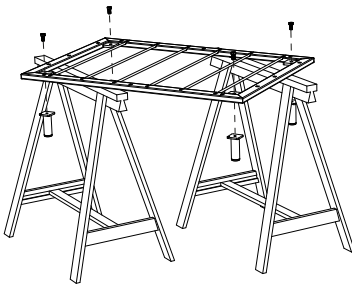
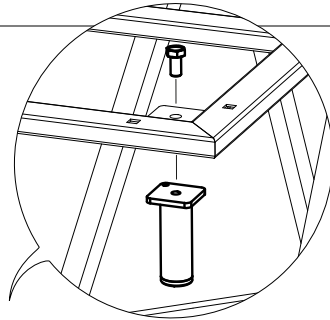

Tighten all bolts!

WAL157

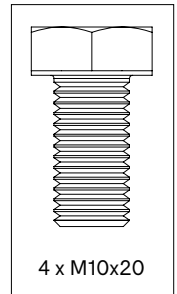

4 x M10x20



3.

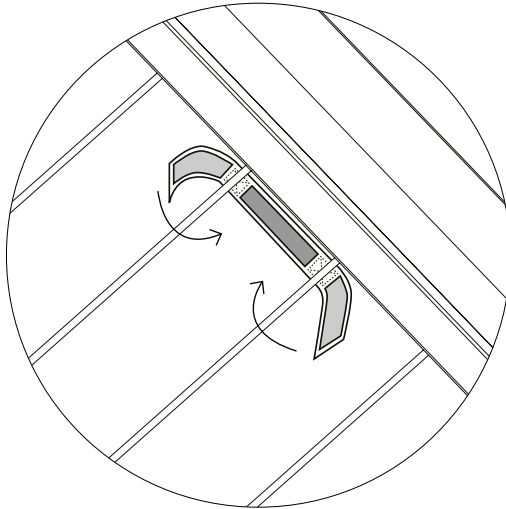
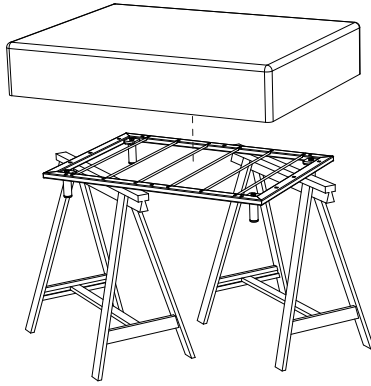

**Fix the seating cushion to the frame attaching the
Velcro straps to the rods**

Remove the trestles

Connection piece

1.

N° 17



15'

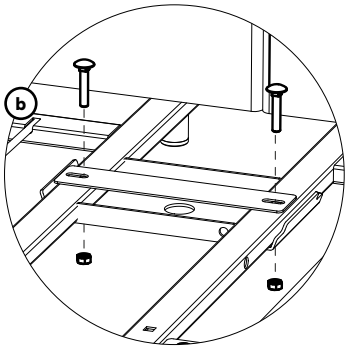
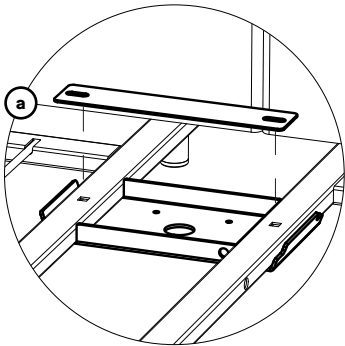
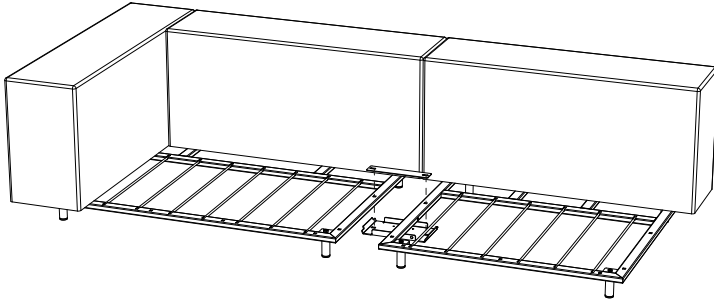

WAL156

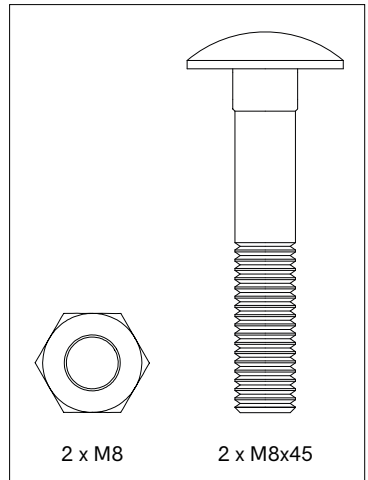

2 x M8

2 x M8x45



Coffee & corner square table

1.

N° 17



5'

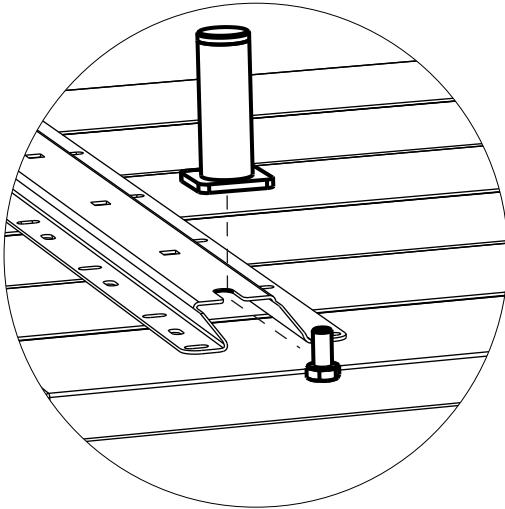
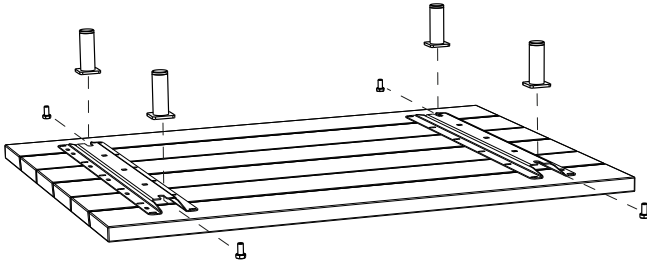

Tighten all bolts!

WAL157

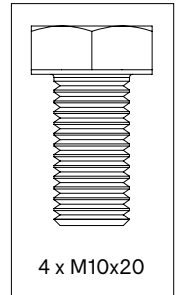

Linking table

1.

N° 17



15'

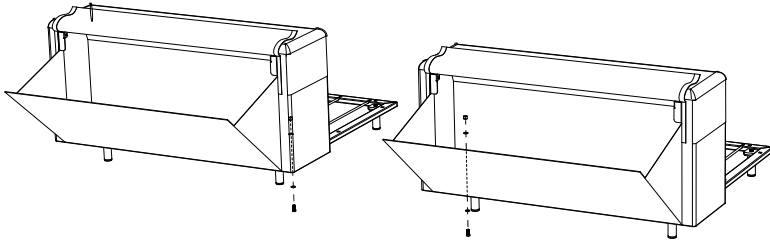

Place the modules +/- 55 cm apart

Remove the the bolts, washers & cap nut from each backrest
(on the side where you want to attach the linking table)

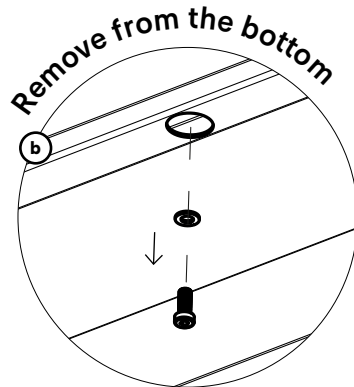
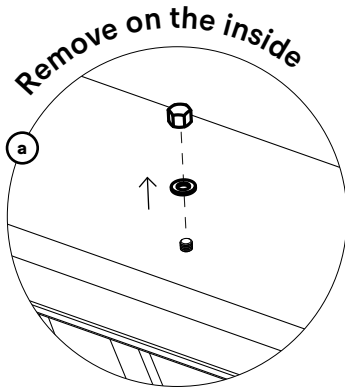

Keep all washers and cap nuts!

2.

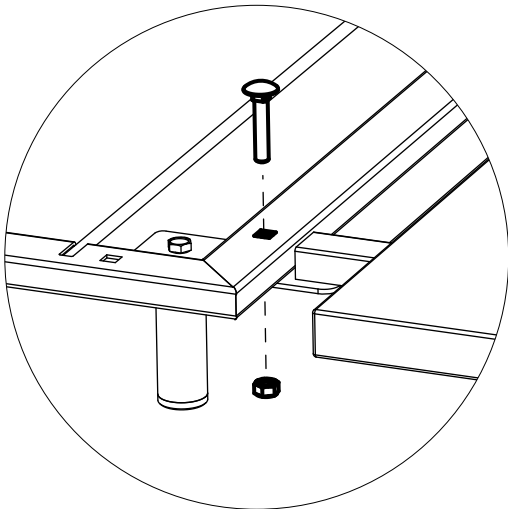
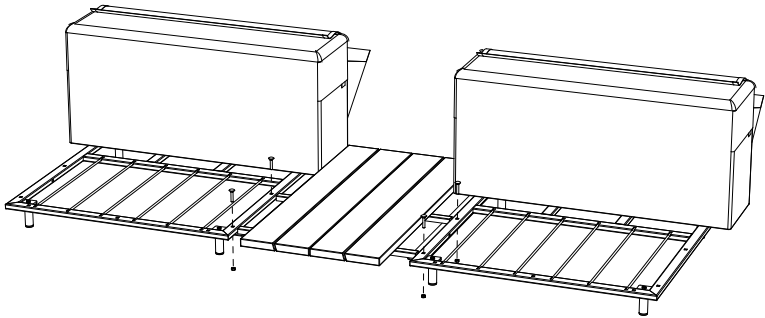
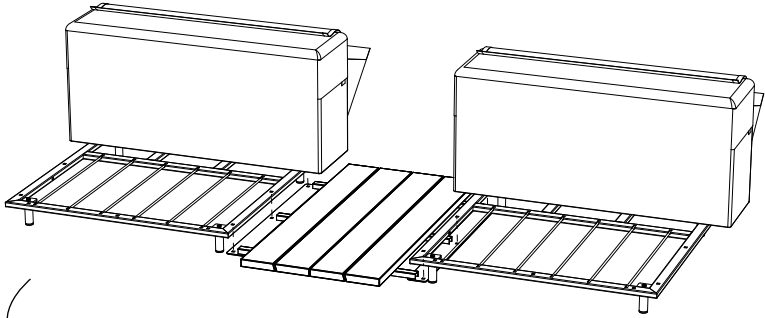

WAL180

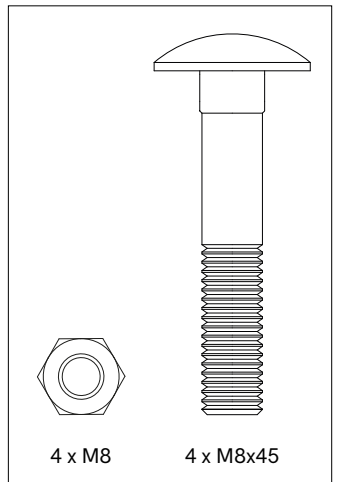

3.

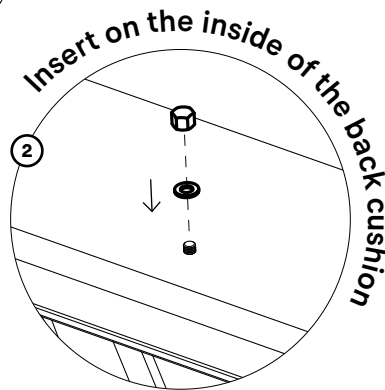
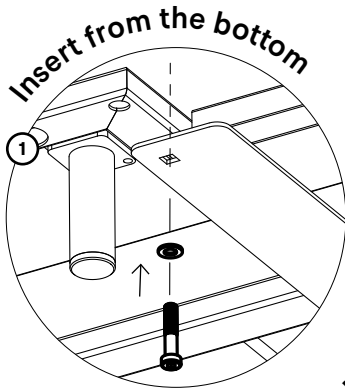
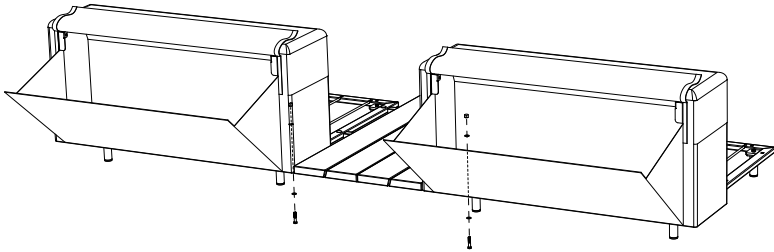

Re-use the washers and cap nuts from the first step

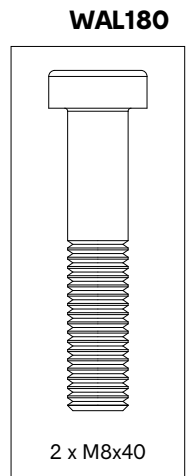

4.

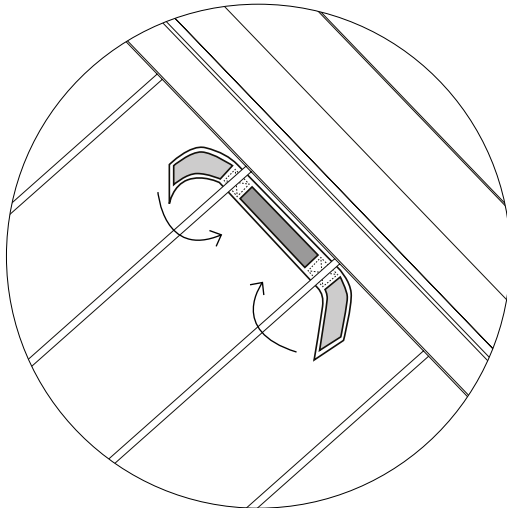
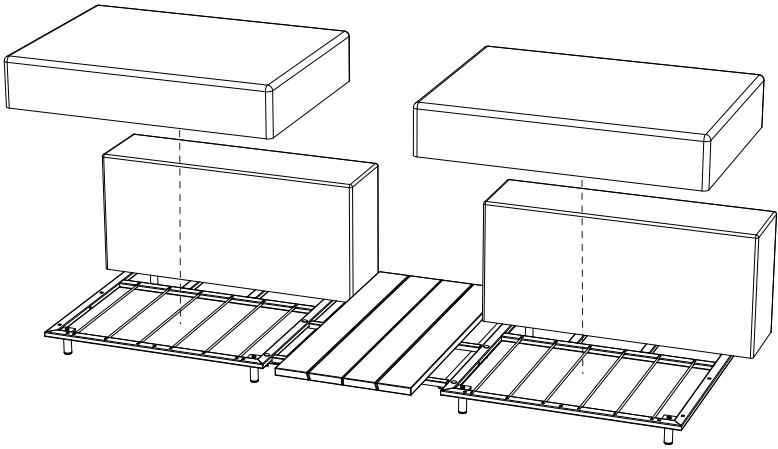

**Fix the seating cushion to the frame attaching the
Velcro straps to the rods**

Warnings

Text instructions

Maintenance

Warnings ↗

Assembly text instructions ↗

Maintenance ↗



Warnings

General

- Do not use any sharp tools to open the packaging.
- We strongly advise against using power tools.
- Tripping hazard, mind your step.
- Do not put out cigarettes on the sofa.
- Not graffiti proof.
- Do not leave children unattended whilst playing on the sofa.
- To avoid danger of suffocation, keep plastic bags away from babies and children.
- Colors can differ over years and from batch to batch.

Product

- We strongly advise storing the blanket & cushions indoors when the Walrus is not used frequently.
- Do not leave iron items such as needles, knives or tools too close to the magnets of the back cushions.
- People with a pacemaker should not come into contact with the magnetic field.
- Keep electrical equipment and data cards away from the magnetic field.
- Keep the magnets away from open flames and heat.
- In order to open and close the storage pouch, the Walrus should be at least 50 cm away from obstacles such as a wall, fence, pool, etc.
- The Walrus is not a toy. Kids and pets don't belong in the storage pouch!
- The Walrus is only compatible with Extremis cushions and blankets.
- Do not stand on the seat and do not lie down on the sofa with your shoes on.
- Keep pets and sharp objects away from the Walrus to avoid damaging the fabric.
- Jeans can leave dye marks on the Walrus tarpaulin, just as they can on other seating fabrics.



- Max. 2 people or 160 kg per module.

Tarpaulin

- We advise cleaning frequently.
- Clean the fabric regularly, don't forget to clean between the cushions, to prevent lasting stains.
- Keep in mind that white is a more sensitive color.
- UV color fastness: 7/8 (ISO 105-B02)
- Flame retarding: Flame speed <100mm/sec - ISO3795 1989.
- Leaves that are not swept off the seat promptly may start fermenting and cause stubborn stains. This is why we highly recommend that you do not put your furniture under a tree.
- Cushions in darker colors can get very hot in the sun. Be aware.

Galvanized steel

- Galvanization will become less shiny when used outdoors.
- Flame retarding - NEN-EN13501-1 A1 - Class A1 products will not contribute to fire in any stage, including fully developed fire. For this reason, they are assumed to be capable of satisfying all requirements of all lower classes as well.
- Possible impurities in the immersion tank can cause black marks during galvanization, which are intrinsic to this industrial finishing technique.
- White marks on this zinc layer are also intrinsic to this procedure and will disappear when the furniture is put outdoors.
- This industrial finishing technique may result in a rougher surface. This is intrinsic to the process.

Fiberglass

- Wear gloves when assembling or dismantling the fiberglass rods. They can cause skin irritations.



Sunbrella

- Not waterproof, store inside!
- Shake or brush off loose dirt immediately.
- UV color fastness: 7/8 (ISO 105-B02).

Wood

- When delivered, the wood is untreated.
- Wood is a natural material and its look is different for every slat, plank and tree.
- Wood will gradually become rougher and start to turn grey as a consequence of exposure to the sun and rain. We recommend oiling the wood once or twice a year. 1x before the Summer and 1x after the Summer as protection for the Winter.
- Cleaning regularly with mild detergent. Never use a high pressure cleaner as this will roughen the wood's smooth surface and irreparably damage the wood's fibress.
- Thorough cleaning with Extremis Wood Cleaner.
- We strongly recommend that you treat your wood with wood oil to protect it from stains - Small cracks and crevices can also appear as part of this process. We strongly advise everyone to treat the furniture with our Wood Protector. It is best to repeat this treatment each year.



Assembly text instructions



Take a look at the drawings, starting from page 13

Club chair 110 (p13)

1. Place the frame on two trestles, with the rods facing upwards so that you can reach the underside more easily.
2. Attach the four feet to each corner of the frame with an M10x20 bolt. Tighten all bolts!
3. Position the backrest in the middle of the back of the frame (the side with no rods). Make sure the storage pouch is facing outwards.
4. Push three M8x20 bolts, each with one M8 spring washer on them, through the underside of the frame so that they come out in the storage pouch of the back cushion and attach them with an M8 cap nut and M8 flat washer. Tighten the bolts!
5. Now attach both armrests to the frame using three M8x20 bolts and M8 spring washers per armrest. Tip: First position the bolt in the front, then the one in the back and finally the center bolt. Tighten all bolts!
6. Finally place the seating cushion on the frame and fix it in place by attaching the Velcro straps to the two rods in the middle.

Club chair 80 (p18)

1. Place the frame on two trestles, with the rods facing upwards so that you can reach the underside more easily.
2. Attach the four feet to each corner of the frame with an M10x20 bolt. Tighten all bolts!



3. Remove the rods on both sides of the frame.
4. Position the backrest in the middle of the back of the frame (the side with no rods). Make sure the storage pouch is facing outwards.
5. Push three M8x20 bolts, each with one M8 spring washer on them, through the underside of the frame so that they come out in the storage pouch of the back cushion and attach them with an M8 cap nut and M8 flat washer. Tighten the bolts!
6. Now attach both armrests to the frame using three M8x20 bolts and M8 spring washers per armrest. Tip: First position the bolt in the front, then the one in the back and finally the center bolt. Tighten all bolts!
7. Finally place the seating cushion on the frame and fix it in place by attaching the Velcro straps to the two rods in the middle.

Corner seat 110/80 (p24/31)

1. Place the frame on two trestles, with the rods facing upwards so that you can reach the underside more easily.
2. Attach the four feet to each corner of the frame with an M10x20 bolt. Tighten all bolts!
3. Remove the rod on the side where you want to fit the armrest.
4. Choose if you want a left or right corner seat. Position the backrest off center on the back of the frame (the side with no rods) as shown on the diagram. Make sure the storage pouch is facing outwards.
5. Push three M8x20 bolts, each with one M8 spring washer on them, through the underside of the frame so that they come out in the storage pouch of the back cushion and attach them with an M8 cap nut and M8 flat washer. Tighten the bolts!
6. Now attach the armrest to the frame using three M8x20 bolts and M8 spring washers. Tip: First position the bolt in the front, then the one in the back and finally the center bolt. Tighten all bolts!
7. Finally place the seating cushion on the frame and fix it in place by attaching the Velcro straps to the two rods in the middle.



Middle seat 110 (p36)

1. Place the frame on two trestles, with the rods facing upwards so that you can reach the underside more easily.
2. Attach the four feet to each corner of the frame with an M10x20 bolt.
Tighten all bolts!
3. Position the backrest in the middle of the back of the frame (the side with no rods). Make sure the storage pouch is facing outwards.
4. Push three M8x20 bolts, each with one M8 spring washer on them, through the underside of the frame so that they come out in the storage pouch of the back cushion and attach them with an M8 cap nut and M8 flat washer. Tighten all bolts!
5. Finally place the seating cushion on the frame and fix it in place by attaching the Velcro straps to the two rods in the middle.

Middle seat 80 (p40)

1. Place the frame on two trestles, with the rods facing upwards so that you can reach the underside more easily.
2. Attach the four feet to each corner of the frame with an M10x20 bolt.
Tighten all bolts!
3. Remove the rod on the side where you want to fit the backrest.
4. Position the backrest in the middle of the back of the frame (the side with no rod). Make sure the storage pouch is facing outwards.
5. Push three M8x20 bolts, each with one M8 spring washer on them, through the underside of the frame so that they come out in the storage pouch of the back cushion and attach them with an M8 cap nut and M8 flat washer. Tighten all bolts!
6. Finally place the seating cushion on the frame and fix it in place by attaching the Velcro straps to the two rods in the middle.

Seat with side table 110/80 (p45/51)

1. Place the frame on two trestles, with the rods facing upwards so that you can reach the underside more easily.



2. Attach the four feet to each corner of the frame with an M10x20 bolt. Tighten all bolts!
3. Remove the rod on the side where you want to fit the side table.
4. Choose if you want the side table on the left or right. Position the backrest off center on the back of the frame (the side with no rods) as shown on the diagram. Make sure the storage pouch is facing outwards.
5. Push three M8x20 bolts, each with one M8 spring washer on them, through the underside of the frame so that they come out in the storage pouch of the back cushion and attach them with an M8 cap nut and M8 flat washer. Tighten the bolts!
6. Now attach the side table to the frame using four M8x12 bolts and M8 spring washers. Tighten all bolts!
7. Finally place the seating cushion on the frame and fix it in place by attaching the Velcro straps to the two rods in the middle.

Corner seat with side table 110 (p57)

1. Place the frame on two trestles, with the rods facing upwards so that you can reach the underside more easily.
2. Attach the four feet to each corner of the frame with an M10x20 bolt. Tighten all bolts!
3. Position the backrest in the middle of the back of the frame (the side with no rods). Make sure the storage pouch is facing outwards.
4. Push three M8x20 bolts, each with one M8 spring washer on them, through the underside of the frame so that they come out in the storage pouch of the back cushion and attach them with an M8 cap nut and M8 flat washer. Tighten the bolts!
5. Choose if you want a left or right corner seat. Attach the armrest to the frame using three M8x20 bolts and M8 spring washers. Tip: First position the bolt in the front, then the one in the back and finally the center bolt. Tighten the bolts!
6. Now attach the side table to the frame using four M8x12 bolts and M8 spring washers. Tighten all bolts!



7. Finally place the seating cushion on the frame and fix it in place by attaching the Velcro straps to the two rods in the middle.

Corner seat with side table 80 (p63)

1. Place the frame on two trestles, with the rods facing upwards so that you can reach the underside more easily.
2. Attach the four feet to each corner of the frame with an M10x20 bolt. Tighten all bolts!
3. Remove the rods on both sides of the frame.
4. Position the backrest in the middle of the back of the frame (the side with no rods). Make sure the storage pouch is facing outwards.
5. Push three M8x20 bolts, each with one M8 spring washer on them, through the underside of the frame so that they come out in the storage pouch of the back cushion and attach them with an M8 cap nut and M8 flat washer. Tighten the bolts!
6. Choose if you want a left or right corner seat. Attach the armrest to the frame using three M8x20 bolts and M8 spring washers. Tip: First position the bolt in the front, then the one in the back and finally the center bolt. Tighten the bolts!
7. Now attach the side table to the frame using four M8x12 bolts and M8 spring washers. Tighten all bolts!
8. Finally place the seating cushion on the frame and fix it in place by attaching the Velcro straps to the two rods in the middle.

Seat with 2 side tables 110 (p70)

1. Place the frame on two trestles, with the rods facing upwards so that you can reach the underside more easily.
2. Attach the four feet to each corner of the frame with an M10x20 bolt. Tighten all bolts!
3. Position the backrest in the middle of the back of the frame (the side with no rods). Make sure the storage pouch is facing outwards.
4. Push three M8x20 bolts, each with one M8 spring washer on them, through the underside of the frame so that they come out in the



storage pouch of the back cushion and attach them with an M8 cap nut and M8 flat washer. Tighten the bolts!

5. Now attach both side tables to the frame using four M8x12 bolts and M8 spring washers per side table. Tighten all bolts!
6. Finally place the seating cushion on the frame and fix it in place by attaching the Velcro straps to the two rods in the middle.

Seat with 2 side tables 80 (p75)

1. Place the frame on two trestles, with the rods facing upwards so that you can reach the underside more easily.
2. Attach the four feet to each corner of the frame with an M10x20 bolt. Tighten all bolts!
3. Remove the rods on both sides of the frame.
4. Position the backrest in the middle of the back of the frame (the side with no rods). Make sure the storage pouch is facing outwards.
5. Push three M8x20 bolts, each with one M8 spring washer on them, through the underside of the frame so that they come out in the storage pouch of the back cushion and attach them with an M8 cap nut and M8 flat washer. Tighten the bolts!
6. Now attach both side tables to the frame using four M8x12 bolts and M8 spring washers per side table. Tighten all bolts!
7. Finally place the seating cushion on the frame and fix it in place by attaching the Velcro straps to the two rods in the middle.

Footstool (p83)

1. Place the frame on two trestles, with the rods facing upwards so that you can reach the underside more easily.
2. Attach the four feet to each corner of the frame with an M10x20 bolt. Tighten all bolts!
3. Finally place the seating cushion on the frame and fix it in place by attaching the Velcro straps to the two rods in the middle.



Connection piece (p85)

1. Place the modules in the correct position in the definitive place where you intend to use the sofa. Place the modules side by side and align them as well as possible.
 - a. Hold the base of the connection piece underneath the two frames, level with the holes intended for attaching the connection piece. Lay the upper plate on top of the frames, also level with the holes.
 - b. Now fix the connection piece using two M8x45 bolts and M8 nuts as shown in the diagram. Tighten the bolts!

Coffee & corner square table (p86)

1. Put the tabletop upside down on a soft surface with the frame facing upwards.
2. Attach the four feet to each corner of the frame with an M10x20 bolt. Tighten all bolts!

Linking table (p87)

1. Place the modules +/- 55 cm apart.
 - a. Remove the cap nut & flat washer on the inside of the storage pouch (on the side where you want to attach the linking table).
 - b. Now also remove the bolt & spring washer from the bottom side of each backrest. Keep all washers and cap nuts!
2. Place the linking table in between the two modules. First attach the linking table to the frames using four M8x45 bolts & M8 nuts.
3. Now push one M8x40 bolt with one M8 spring washer (per backrest), through the underside of the frame so that it comes out in the storage pouch of the back cushion and attach them with the M8 cap nut and M8 flat washer. Tighten the bolts!
4. Finally place the seating cushion on the frame and fix it in place by attaching the Velcro straps to the two rods in the middle.





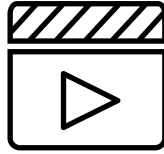

Watch the maintenance videos on our website:

www.extremis.com/maintenance

Tarpaulin

CLEANING SPILLED LIQUIDS IMMEDIATELY

Regularly and after every use

We advise you to clean the sofa regularly to avoid dirt to pile up. Never allow stains to soak into the tarpaulin. Soak up anything likely to cause a stain immediately with a soft, clean cloth or sponge. (Never use the scouring side of the sponge). Never rub too hard and be sure not to use abrasive cleaning products. This can damage the protective coating which will lead to the tarpaulin absorbing dirt more quickly. Do not only treat the dirty spot, but the surrounding area of the tarpaulin as well.

THOROUGH CLEANING

When dirty

Use an Extremis brush and Extremis multi cleaner, a 100% biodegradable detergent, or detergents you also use to clean your kitchen. What if the stain has still not completely disappeared after you have done this? Don't panic. The stain will fade away almost completely in the sunlight.



Galvanized steel

CLEANING

When dirty

Clean with lukewarm water and a brush.

REPAIRING DAMAGED PARTS WITH ZINC SPRAY

When damaged

Hot dip galvanization is the most durable way of protecting metal against rusting. If the zinc coating is damaged, the exposed metal can rust. This can easily be touched up with zinc paint that automatically has the same colour and is readily available in shops. Zinc spray forms a quick drying, self healing and flexible coating that helps stop corrosion.

Fiberglass

CLEANING

Once in a while

The fiberglass rods do not require special maintenance. They can simply be kept dustfree with a slightly damp cloth.

USEFULL ADVICE

When you disassemble the Sticks space divider, bundle the rods with the same side up or down, as the base sometimes leaves marks on the rods. When re-inserting the rods in the base, make sure they are facing the same way as they did before the disassembly.

Sunbrella

SPILLED LIQUIDS

Immediately after use

It is best to treat spilt liquids immediately by placing a sheet of absorbent kitchen paper on them. The water-resistant coating on the Sunbrella



prevents droplets from penetrating the fabric.

REGULAR CLEANING

When dirty

Make a solution to remove stains on your Sunbrella.

MACHINE WASHING

Rarely

It is also possible to put the blankets and cushion covers in a washing machine (30°). Do not dry clean or tumble dry. The fabric can be creased. Ironing will help to recover the waterrepellent coating of the fabric, but only at a cool setting (delicates). As some irons exceed the recommended temperature at the synthetic setting, test a small, inconspicuous area before ironing the entire fabric. DO NOT use a steamer or iron set to the steam setting.

If the cushion has metal brackets, we recommend turning the cover inside out first to avoid damaging the washing machine. In this case, leave the zipper open about 10 cm.

REMOVING STUBBORN STAINS

Only if nothing else helps

More drastic measures needed? Bleach can be used if nothing else helps. Protect the area around your Sunbrella fabric when using a bleach solution – bleach may discolour non-Sunbrella fabrics. Please be aware of the environment when cleaning with bleach. Bleach can have harmful effects on the natural environment around you. We do not advise using bleach if you are surrounded by a body of water or another environment that could be affected. If stains and/or mildew marks are severe, the quantity of bleach may be increased.



Wood

OILING

Twice a year

Before first use and/or after cleaning and sanding, we strongly recommend treating the wood with Extremis Wood Protector to protect it from dirt, moisture and UV rays.

DAY TO DAY CLEANING

Regularly and after every use

Schedule regular maintenance to prolong the life of your garden furniture Regular maintenance ensures that the furniture always looks its best.

Cleaning the wood regularly and immediately after use with a clean, damp cloth ensures that liquids cannot penetrate deep into the wood. A well oiled table is less likely to absorb liquids and thus stays cleaner for longer. To remove stubborn dirt, simply use a hard brush and some water. Be careful not to cause permanent damage to the fibres. For this reason, you should never, ever use a high-pressure washer for cleaning wood.

THOROUGH CLEANING

Twice a year

It is essential to clean the wood thoroughly twice a year. We recommend doing this just before spring and after summer if your furniture is outside all the year round. Pick one of those humid, cloudy days, as it is better for the moisture level in the wood to dry out slowly after cleaning.

SANDING WOOD

Every 2 years

After a few years, your wood will show cracks and perhaps some distortion. This is perfectly normal as wood is a natural and living material. The great advantage of solid wood is that you can sand away



the top layer to make the surface even and smooth again. You should do this every two years using a hand sanding machine. Choose a dry day. Finish off with a 120-grit sandpaper.

REPLACING A WOODEN PART

Hey! You don't need to be an engineer to understand our products. And you don't even need to be great at DIY to replace a part. Do make sure that you can't repair the damage simply by sanding the slat.





Our headquarters:
Couthoflaan 20b
B-8972, Poperinge
info@extremis.com
+ 32 57 346020

extremis.com

Connect with us



All rights reserved. Unless otherwise specified, all designs and photographs contained in this publication are copyright protected and are the property of Extremis. No part of this publication may be copied or distributed without Extremis' prior written consent. The names of the authors of photographs to which we do not hold rights are mentioned here. We have done our utmost to provide a comprehensive list of names. In the event of an alleged breach, please contact the editorial staff. © Extremis

LAB199