

AMAi

Galvanized version

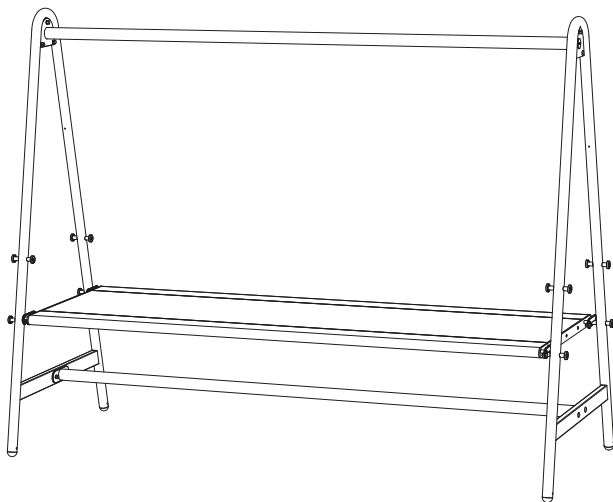

extremis®

**IMPORTANT! RETAIN FOR FUTURE
REFERENCE: READ CAREFULLY.**

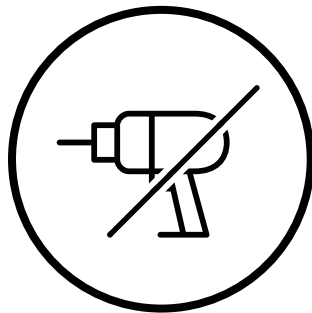

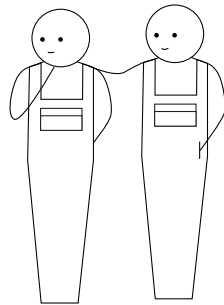
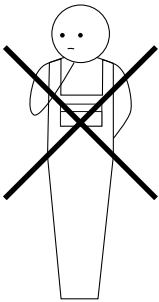
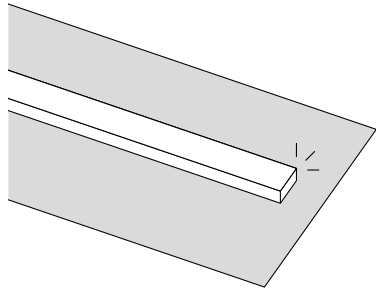
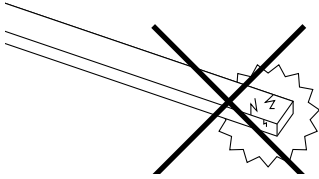

Table of contents ^{1/3}

Mounting kit [↗]

Exploded view [↗]

Assembly standard module [↗]

Assembly extension module [↗]

This is an interactive PDF

You can easily navigate through this manual, allowing you to smoothly jump from one page to the other.

Table of contents ^{2/3}

Add-on table [↗]

Assembly screenholder [↗]

Assembly tabletop fixation [↗]

Assembly leveling feet [↗]

This is an interactive PDF

You can easily navigate through this manual, allowing you to smoothly jump from one page to the other.

Table of contents ^{3/3}

Assembly floor fastening [↗]

**Warnings - Text instructions -
Maintenance [↗]**

This is an interactive PDF

You can easily navigate through this manual, allowing you to smoothly jump from one page to the other.

Mounting kit

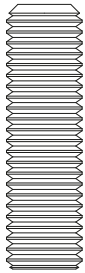

2 x M10x35

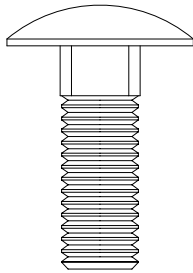

4 x M10x25

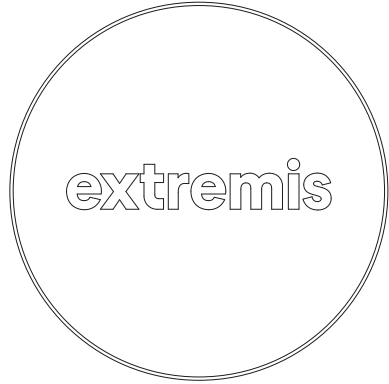

2 x dop

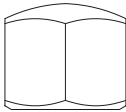

12 x M10

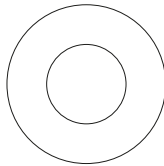

12 x washer M10

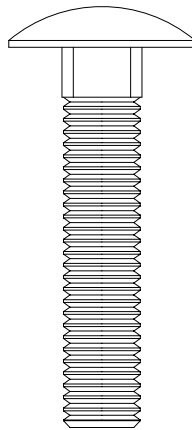

4 x M10x45

Mounting kit **AMA285** to fix A-frames



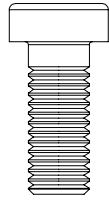

8 x M8x20

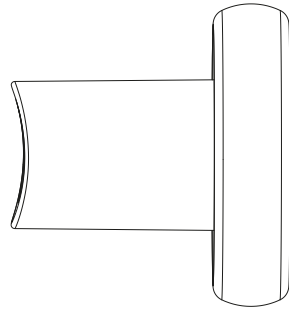

8 x Plastic cap



4 x Connector axis

Mounting kit **AMA201-1** to fix the black dots to the A-frame

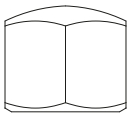

8 x M10

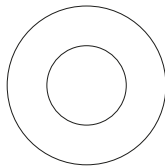

8 x M10

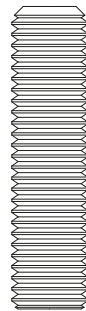

3 x M10x40

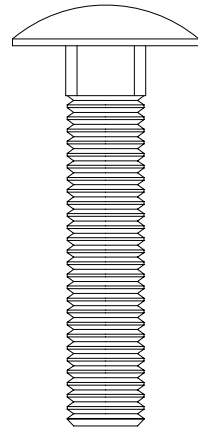

2 x M10x50

Mounting kit **AMA239-1** to fix the extension module





4 x spacer

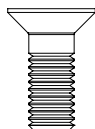

4 x M6x16

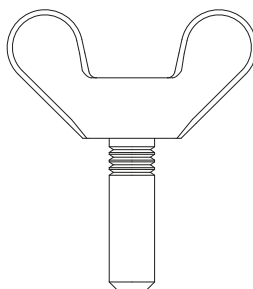

4 x M6x20

Mounting kit **AMA440** to fix the tabletop fixation

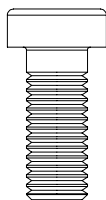

2 x M8x20

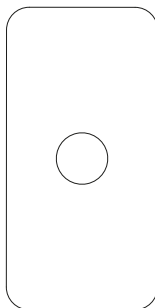

2 x connection plate

Mounting kit **AMA442** to fix the floor fastening feet



4 x Spacer



4 x M4x20

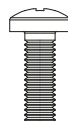

4 x M4x12

Mounting kit **AMA435** to fix the screenholder



Exploded view

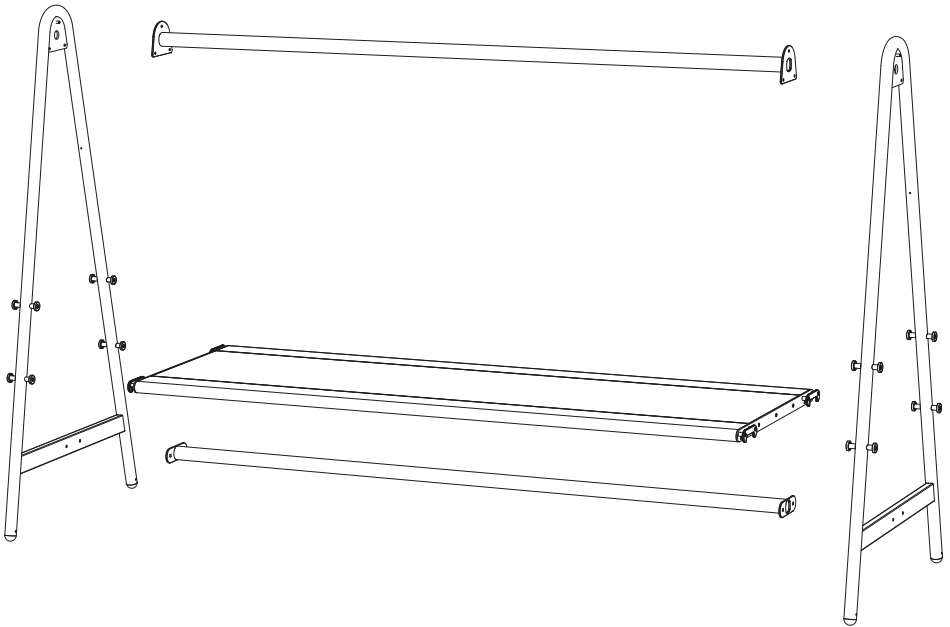

Standard module - Galvanized

1.

N° 5

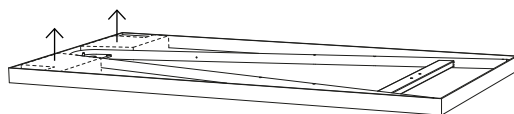

N° 17



20'

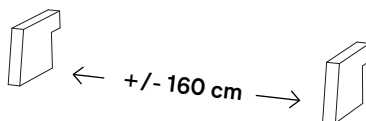

Use the polystyrene blocks in the packaging of the A-frames for the rest of the assembly!

2.

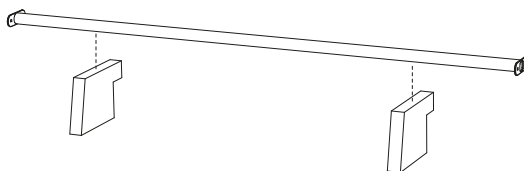

3a.

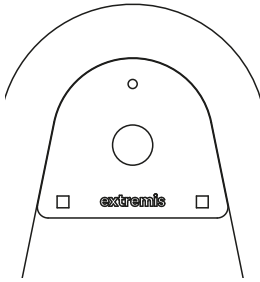

**Logo on the outside
on both sides**

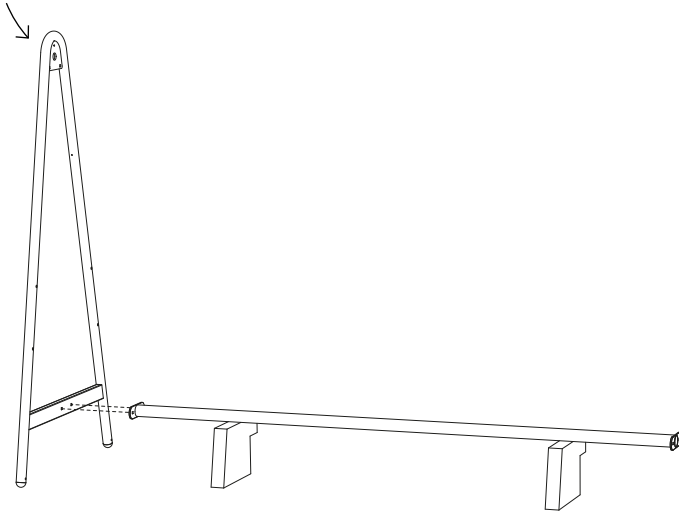

3b.

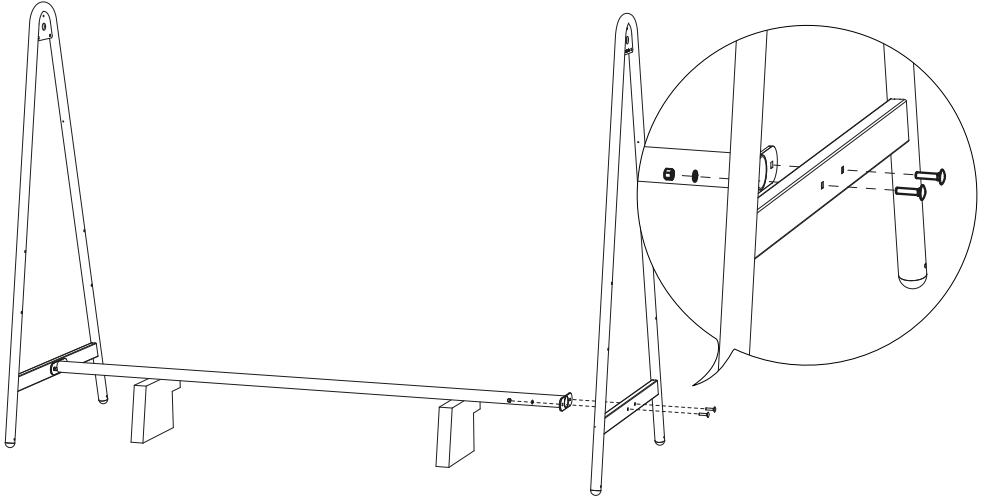

Do this for both A-frames,
do not tighten!

AMA285

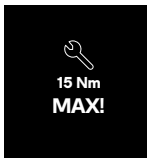

Tighten carefully!
Excessive force may
damage the coating!

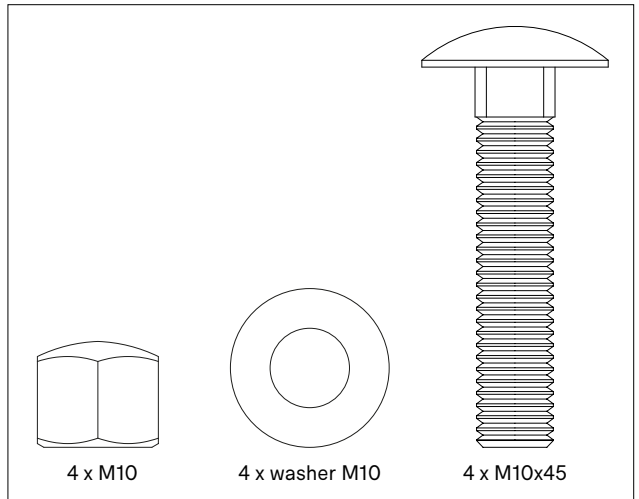

4.

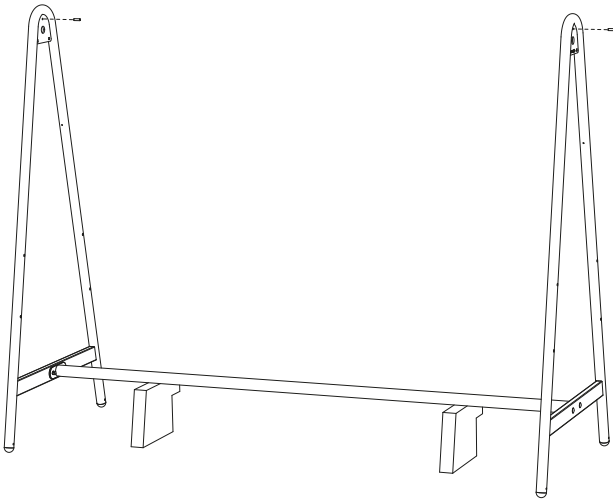
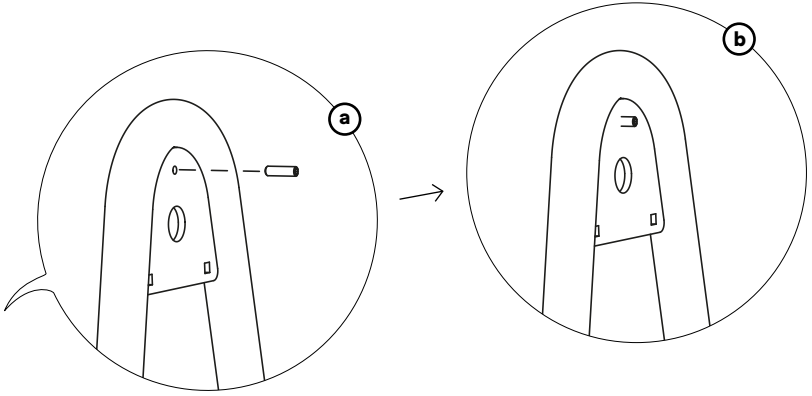

Make sure the set screw is centered to the A-frame. Do this for both A-frames.

AMA285

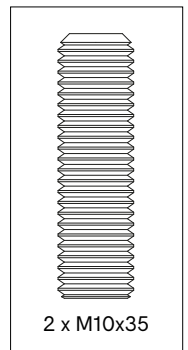

5.

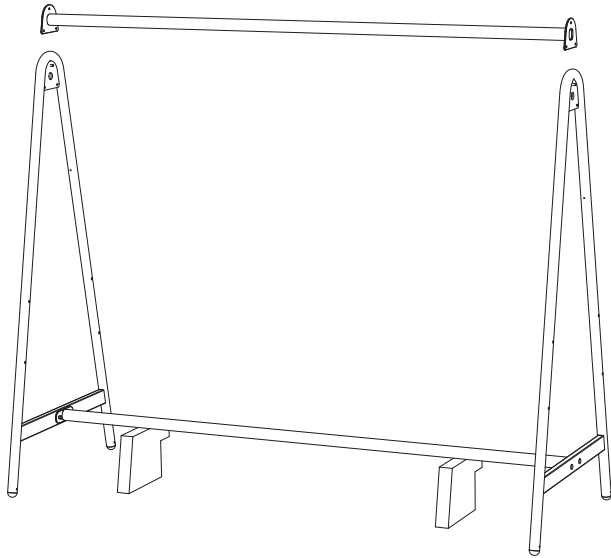
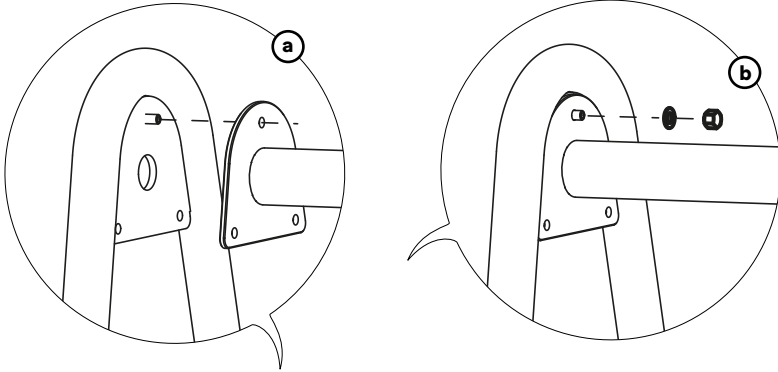

AMA285

Do this for both sides

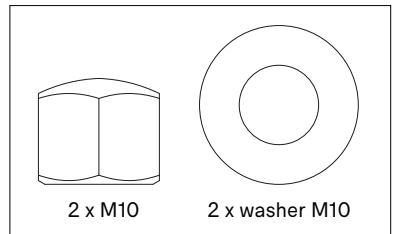

6.

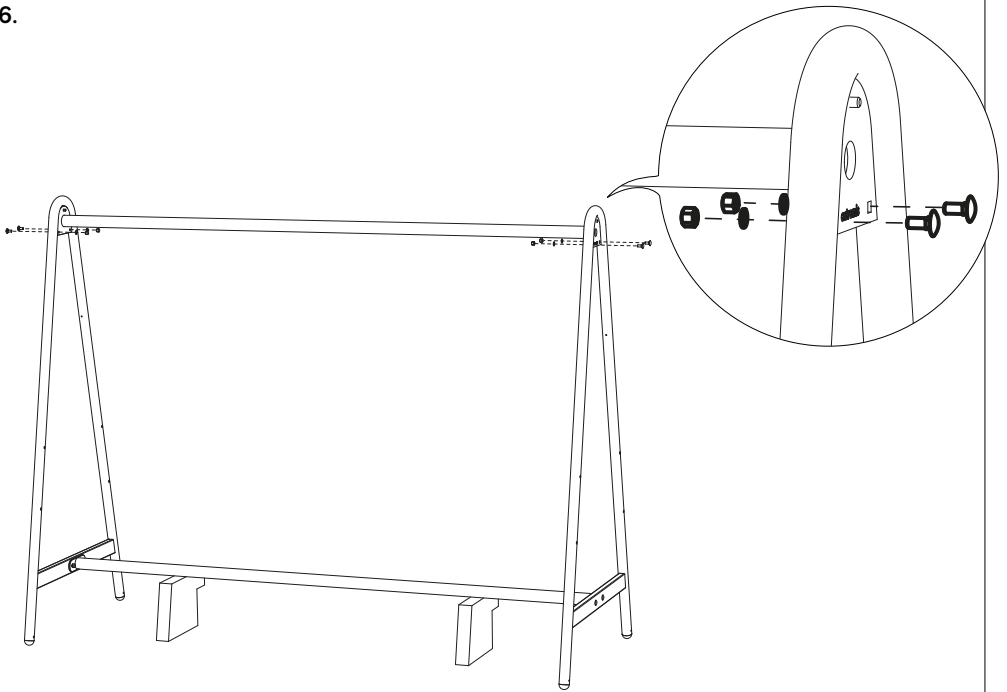

**Do this for both A-frames,
tighten all bolts!**

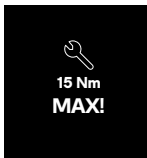

AMA285

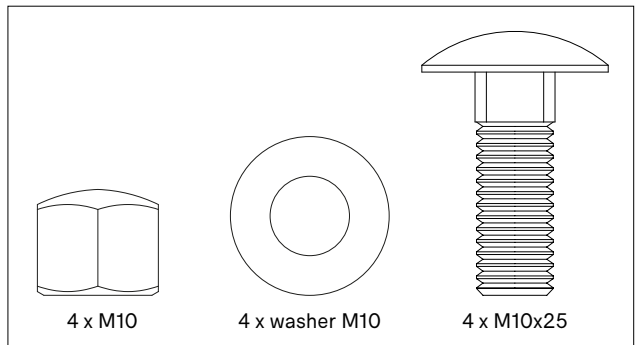

Tighten carefully!
Excessive force may
damage the coating!

7.

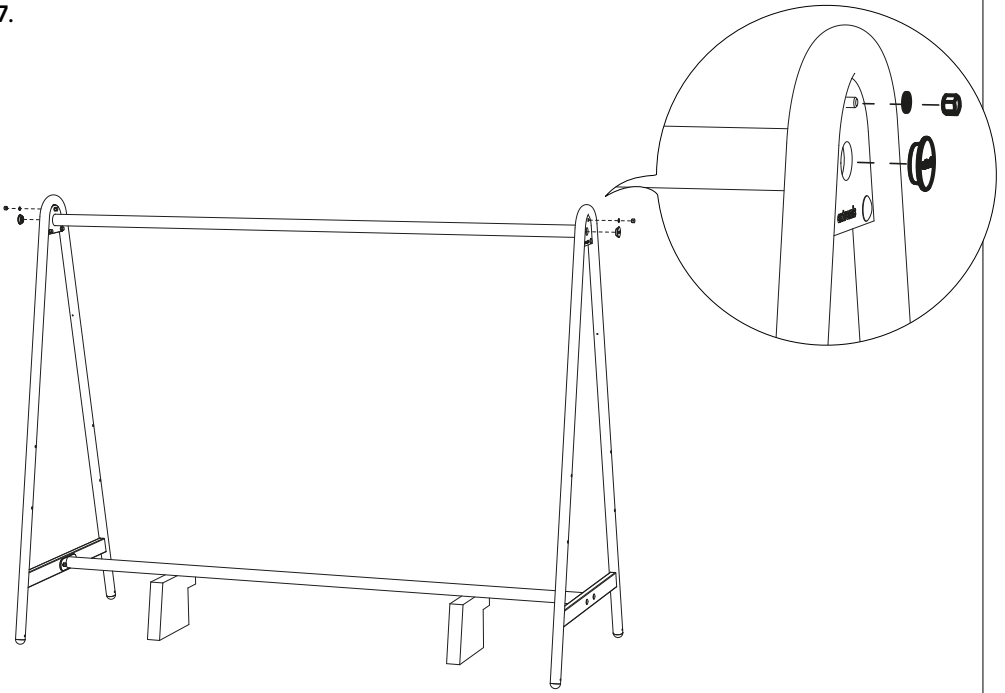

Do this for both A-frames

AMA285

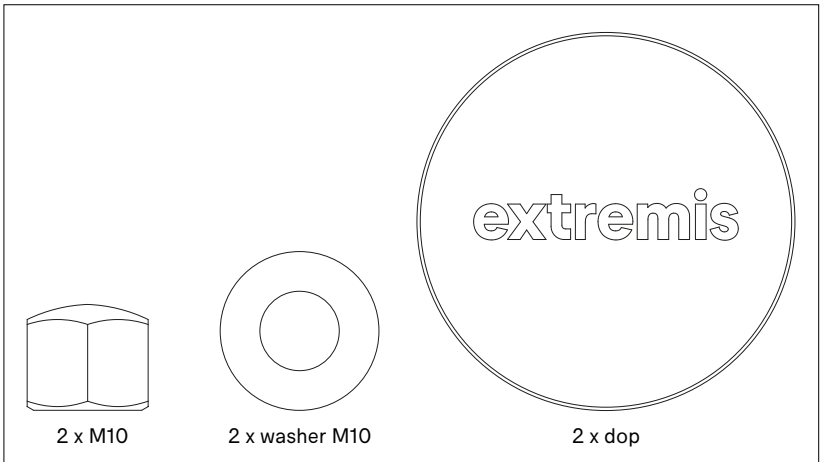

8.

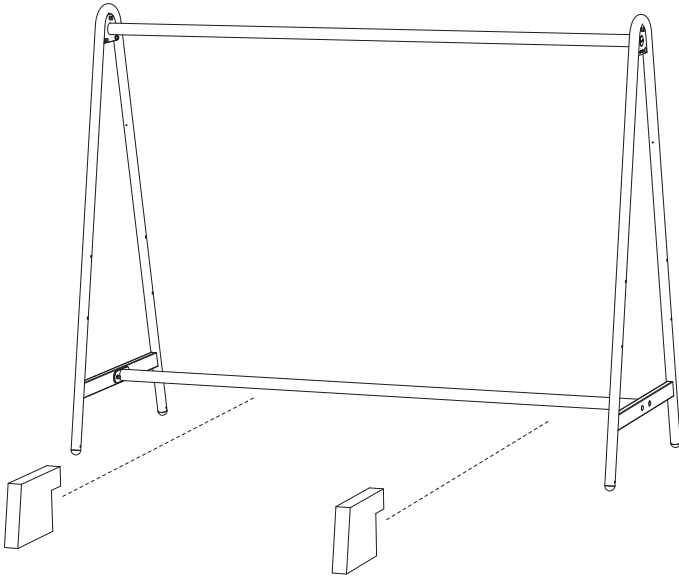

Remove the polystyrene blocks

9.

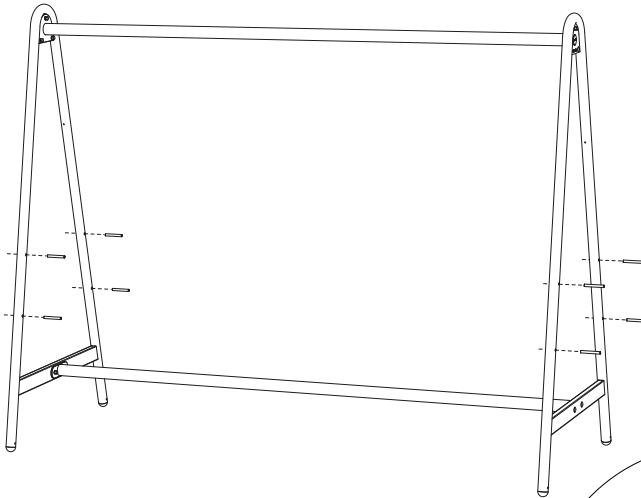

Do this for both A-frames

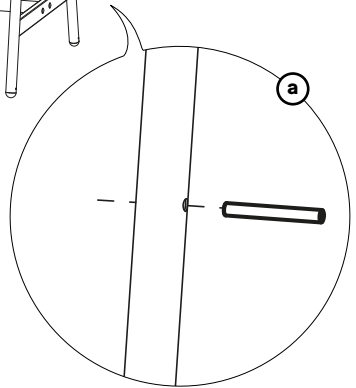
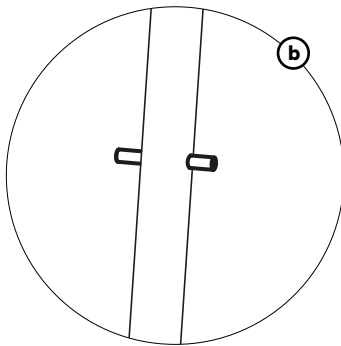

AMA201-1
per A-frame

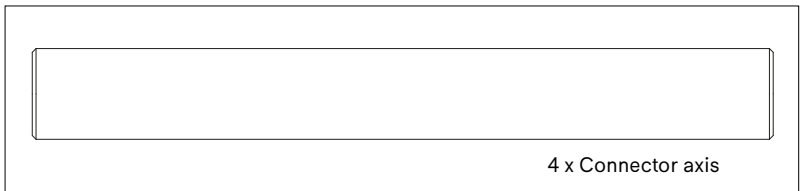

4 x Connector axis

10.

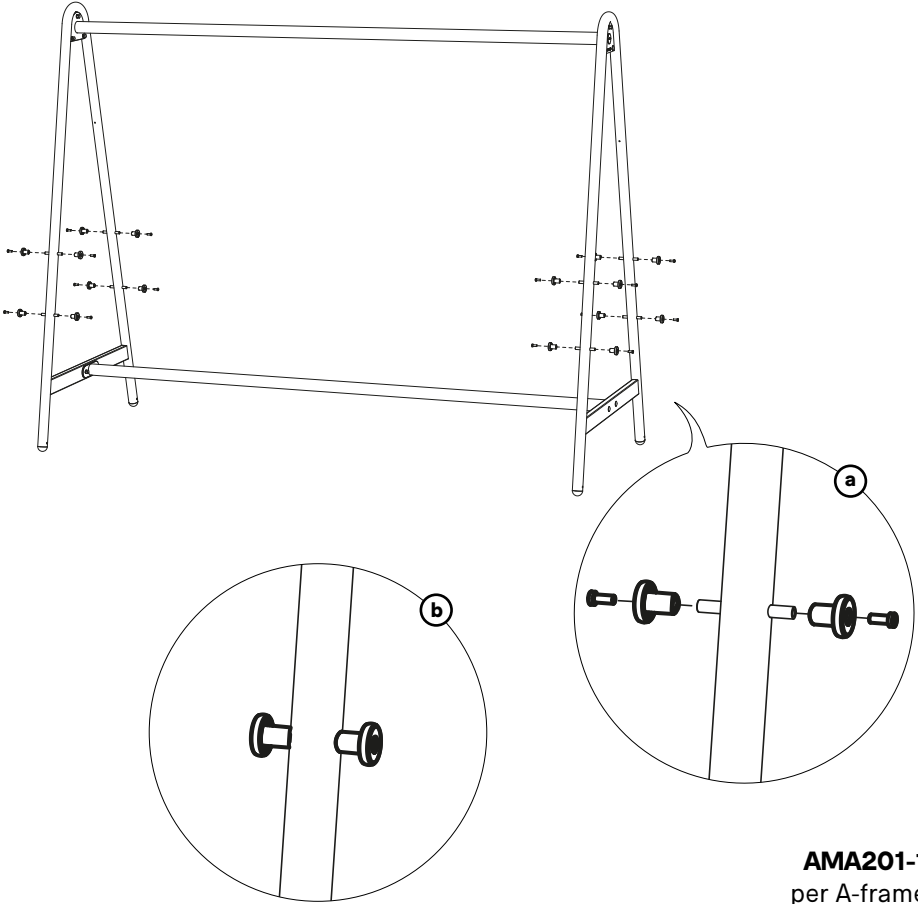

AMA201-1
per A-frame

Do this for both A-frames

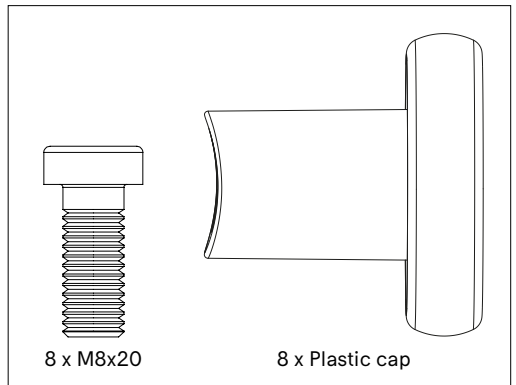

8 x M8x20

8 x Plastic cap

11.

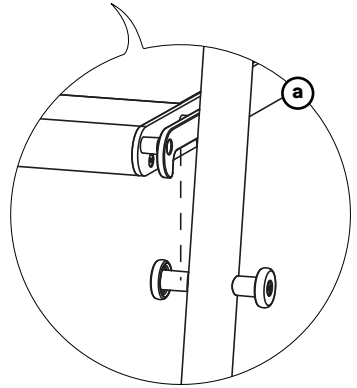
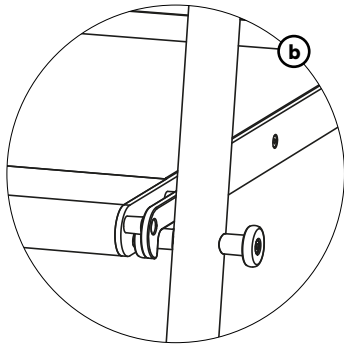
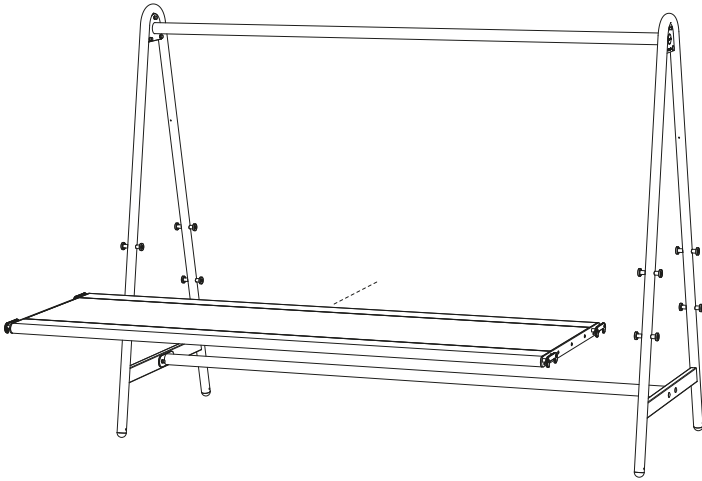

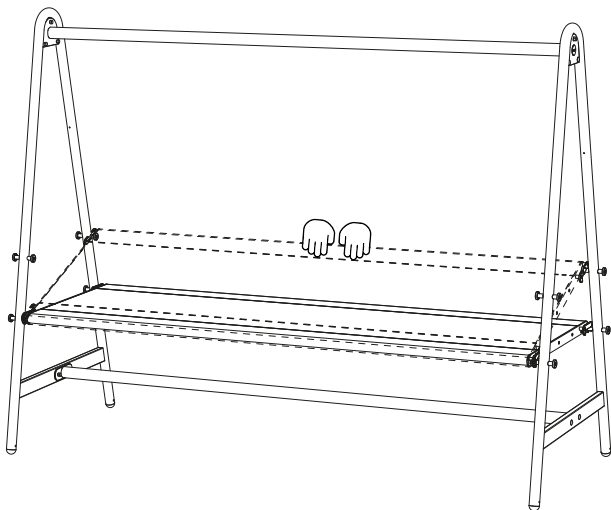

1st side up and pull.
Always make sure to hold the tabletop at its center when moving it up and down!

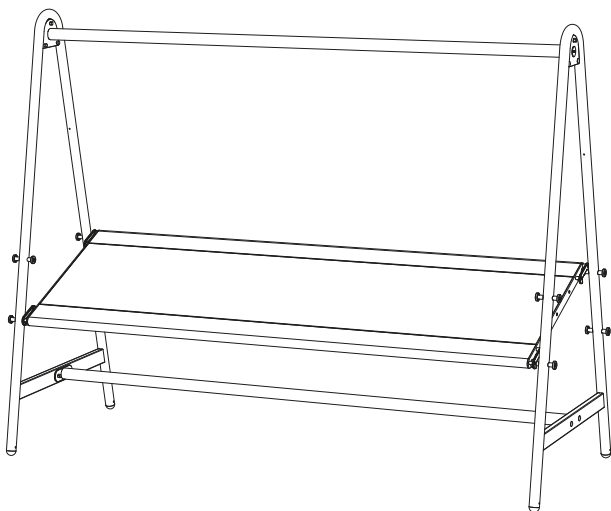

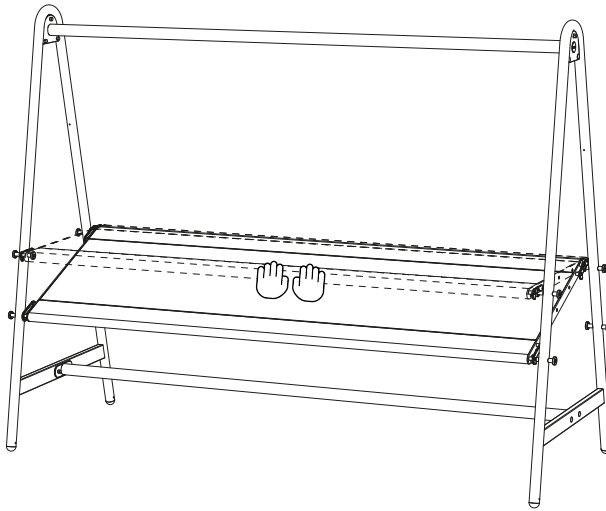

2nd side up and push.
Always make sure to hold the tabletop at its center when moving it up and down!

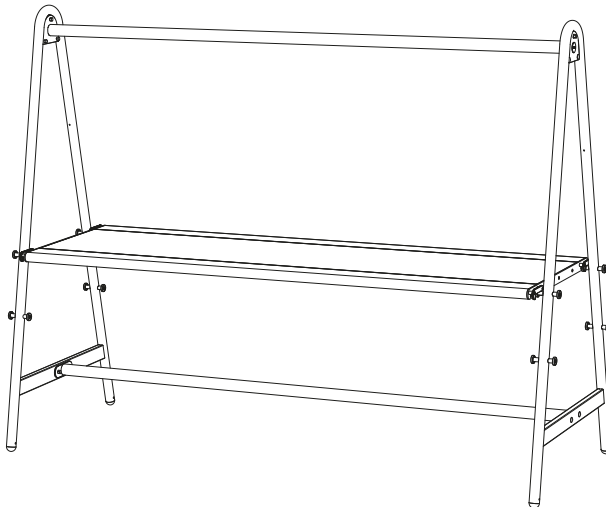

Extension module - Galvanized

1.

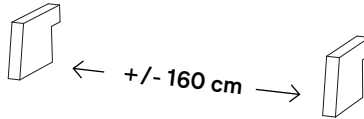
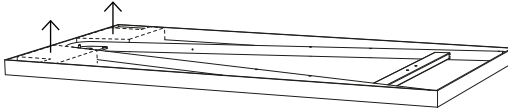

N° 5



N° 17



20'



Use the polystyrene blocks in the packaging of the A-frames for the rest of the assembly!

2.

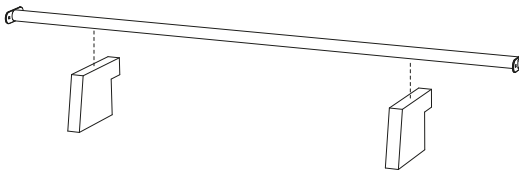

3a.

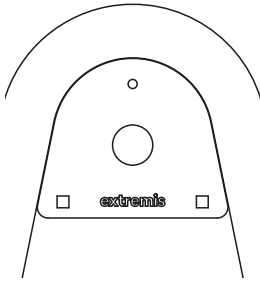

Logo on the outside

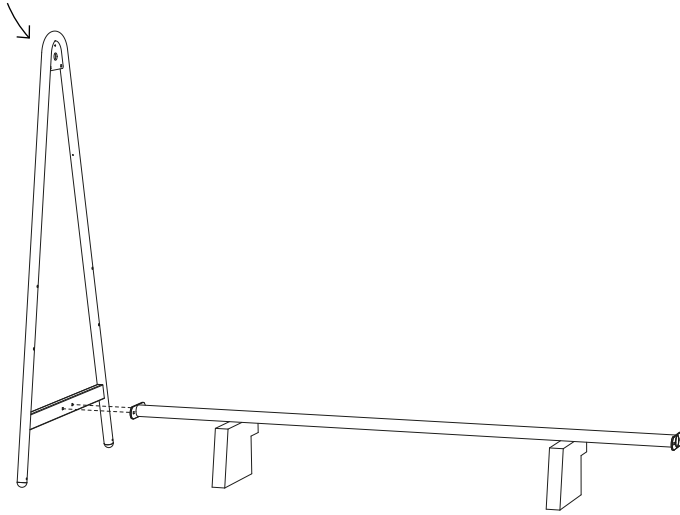

3b.

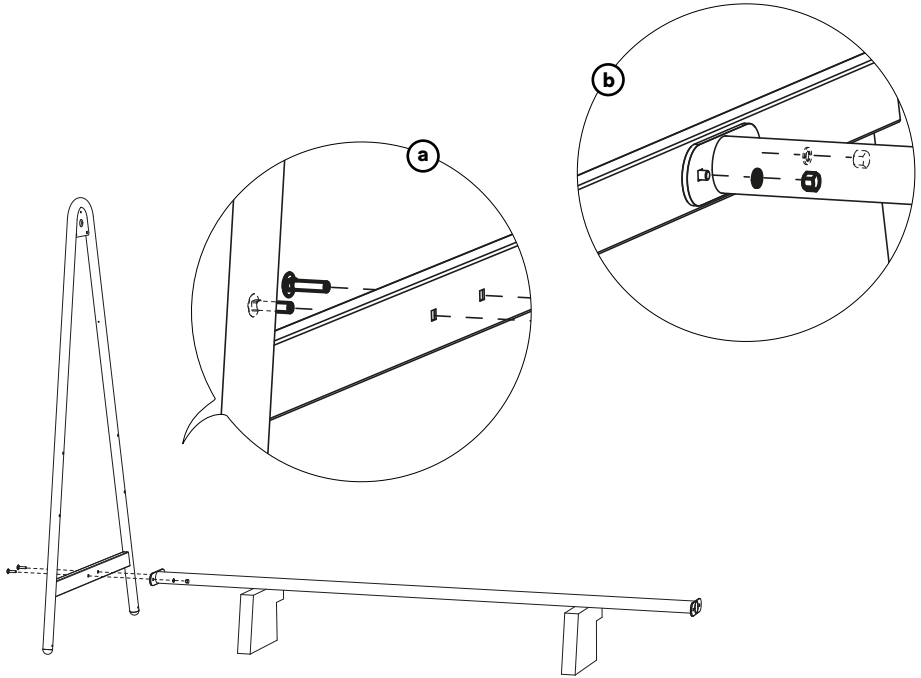

Do not tighten!

AMA285

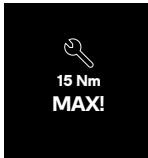

Tighten carefully!
Excessive force may
damage the coating!

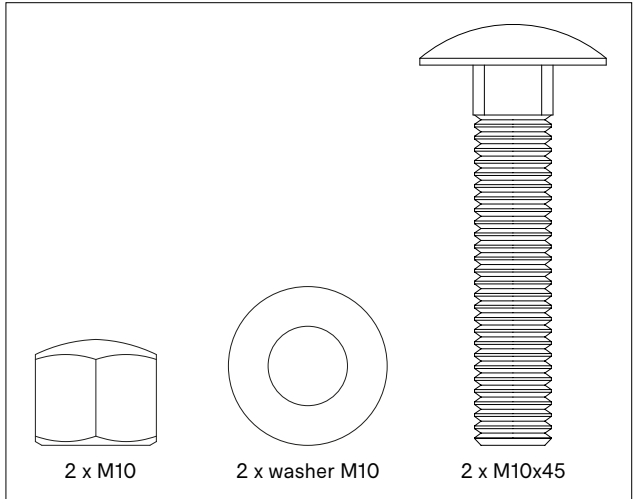

4.

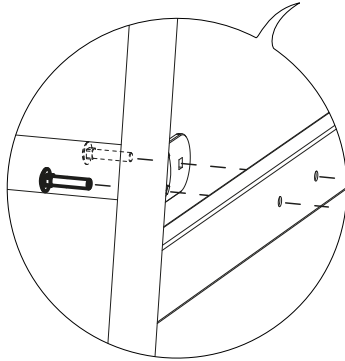
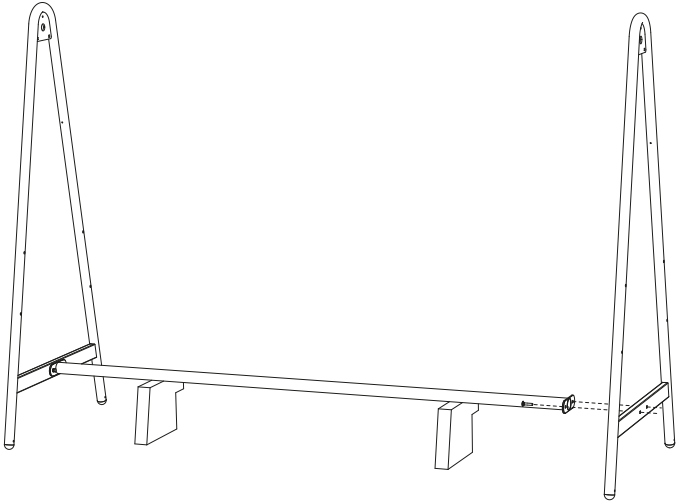

AMA239-1

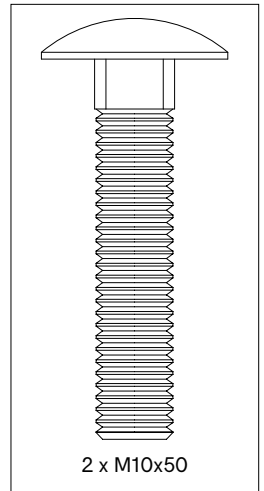

2 x M10x50

5.

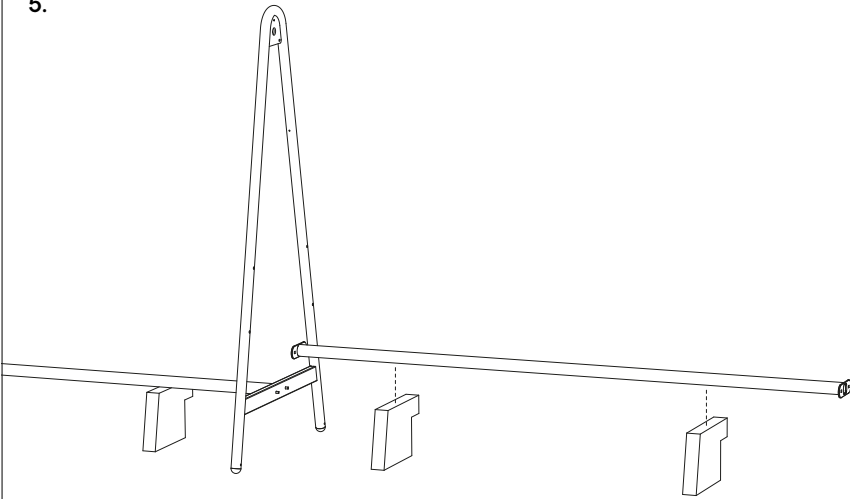

6.

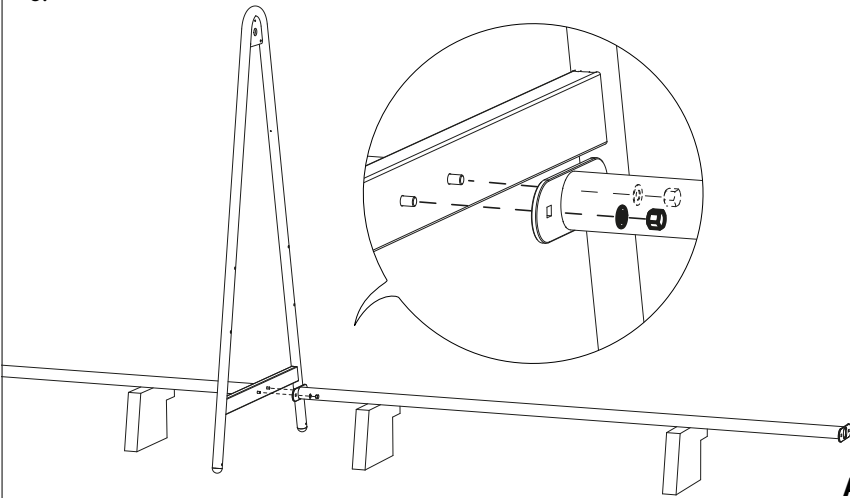

AMA239-1

Do not tighten!

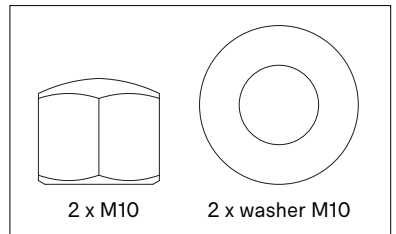

7a.

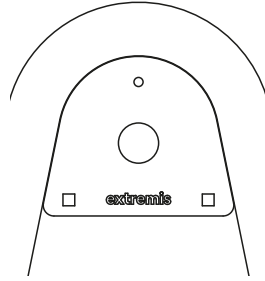

Logo on the outside

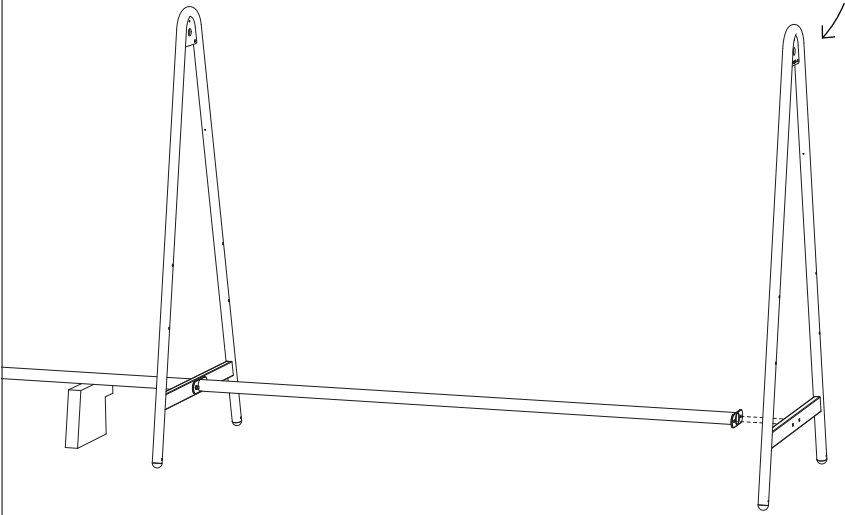

7b.

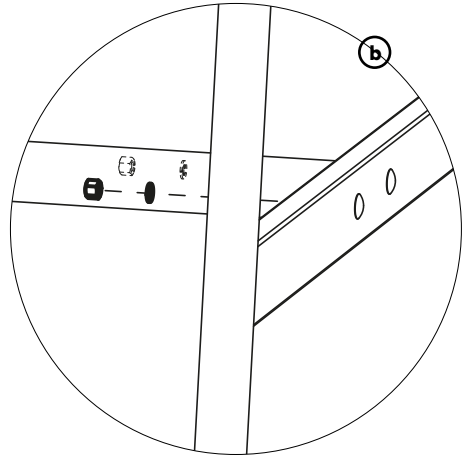
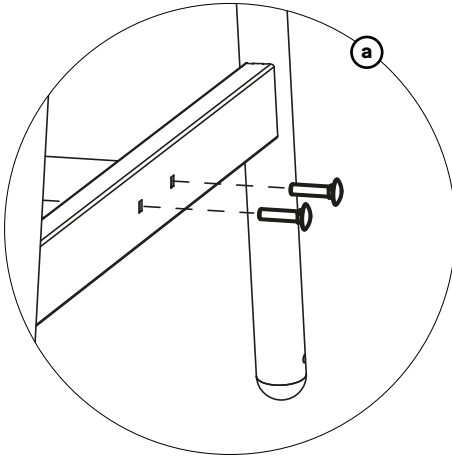

Do this for both sides

AMA285

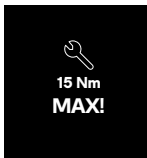

Tighten carefully!
Excessive force may
damage the coating!

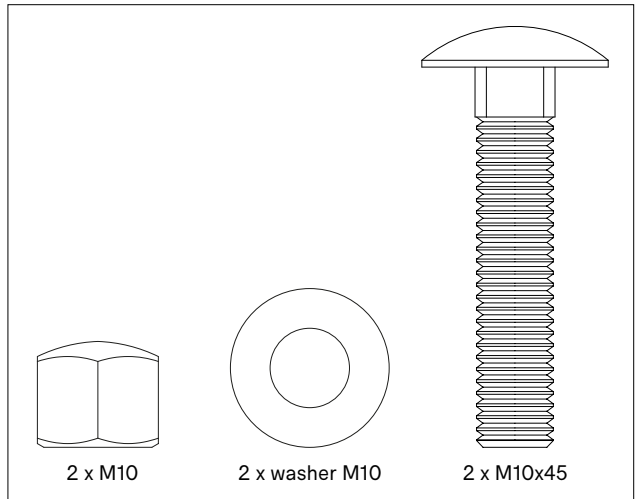

8.

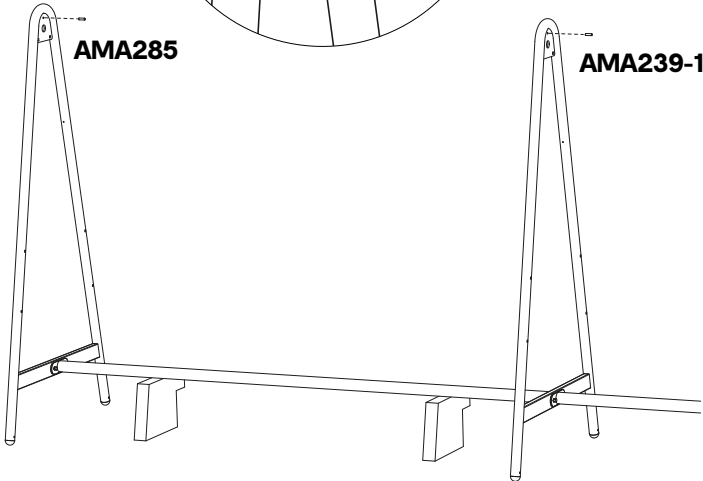
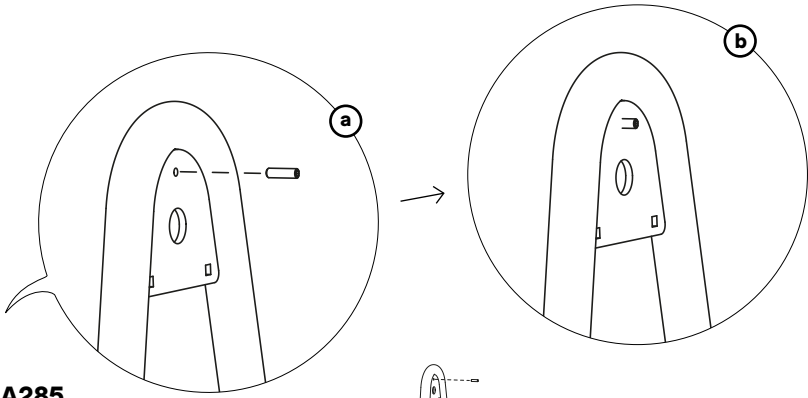

AMA285
per outer
A-frame

AMA239-1
per center
A-frame

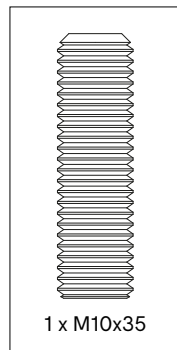

1 x M10x35

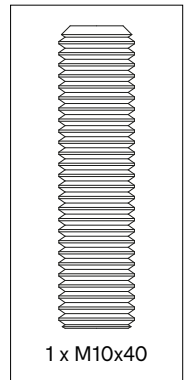

1 x M10x40

Make sure the set screw is centered to the A-frame.

9.

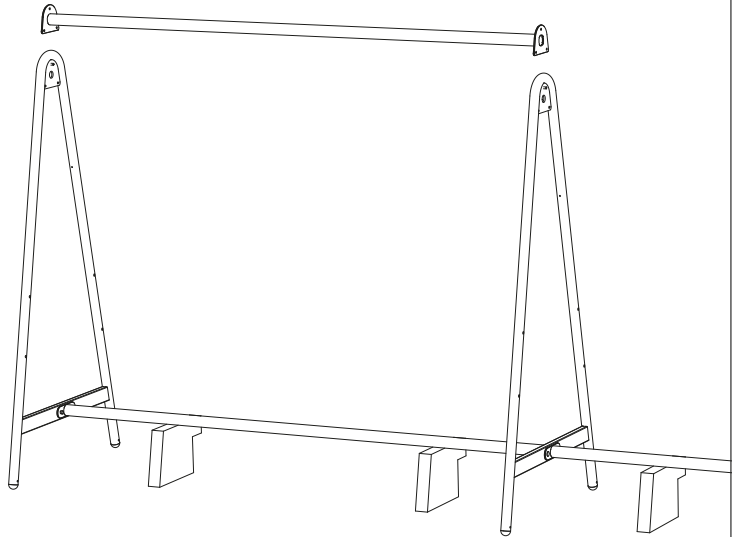
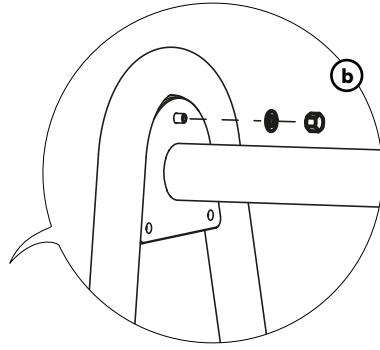
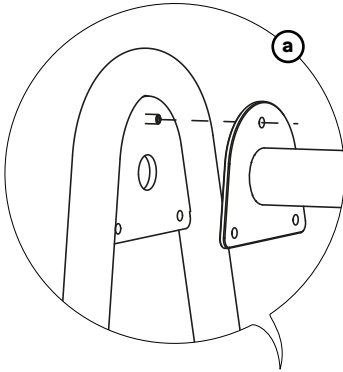

AMA285

Do this for both sides

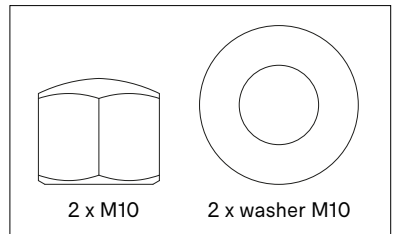

10.

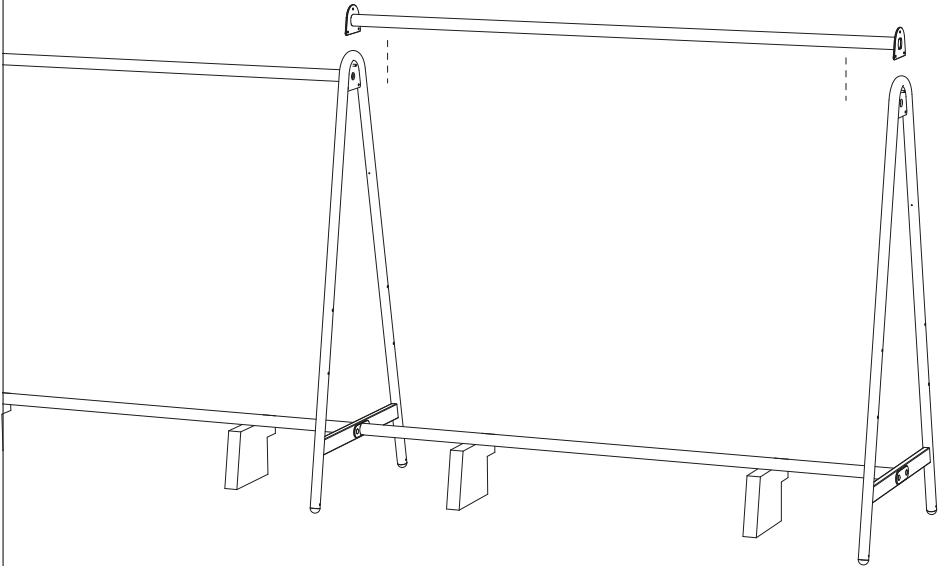
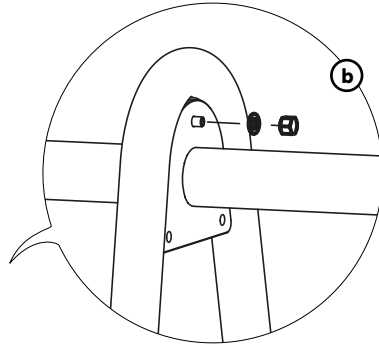
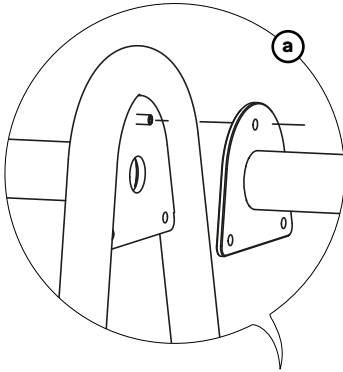

AMA285

Do this for both sides

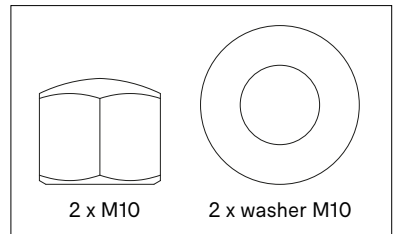

11a.

Do this for both outer A-frames,
tighten all bolts

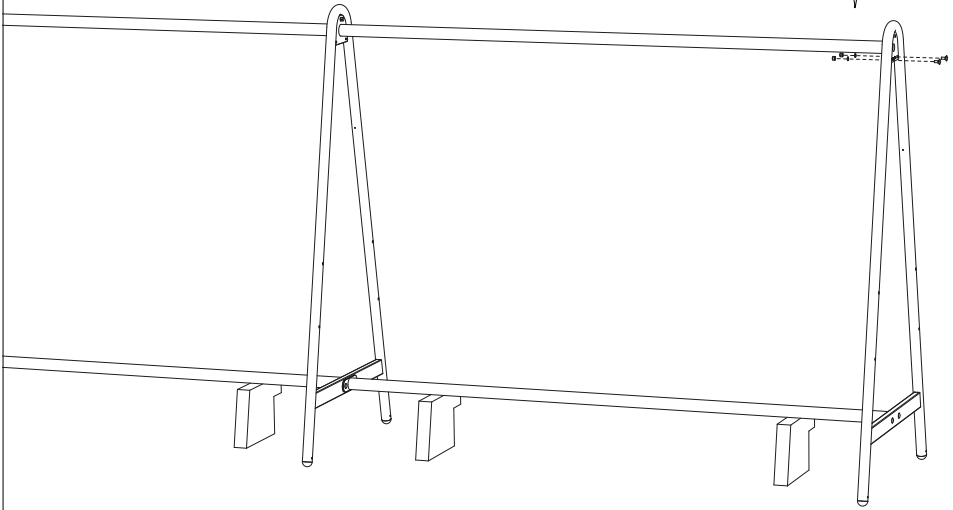
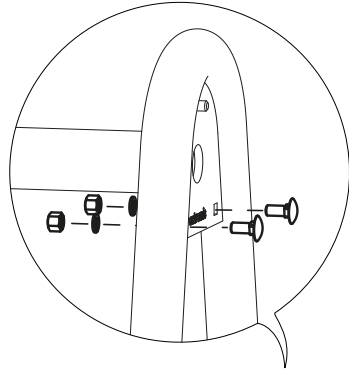

AMA285
per outer
A-frame

15 Nm
MAX!

Tighten carefully!
Excessive force may
damage the coating!

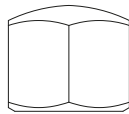

2 x M10

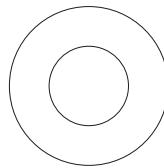

2 x washer M10

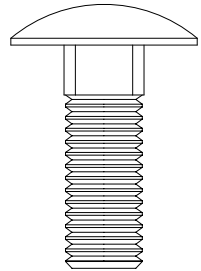

2 x M10x25

11b.

Do this for all
center A-frames

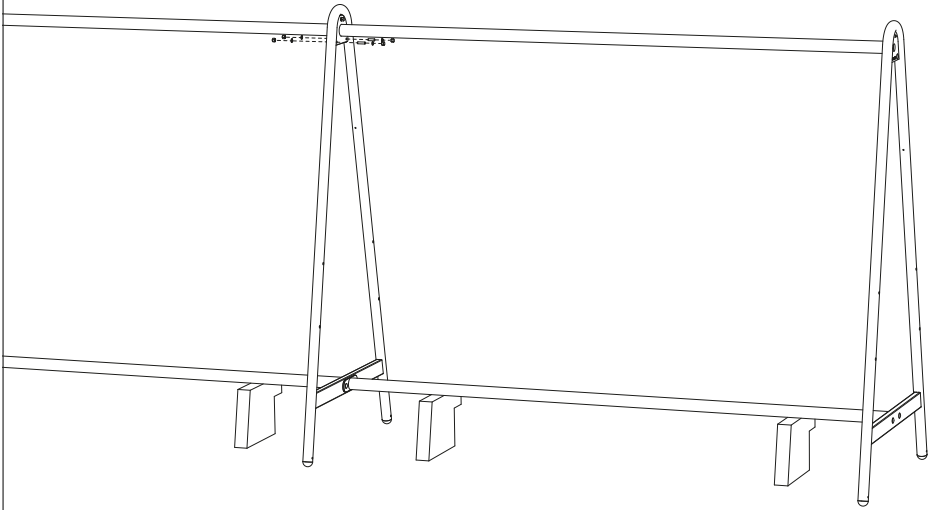
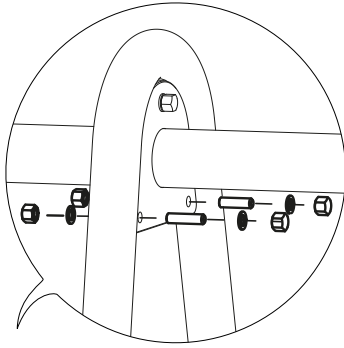

AMA239-1
per center
A-frame

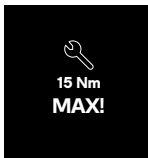

Tighten carefully!
Excessive force may
damage the coating!

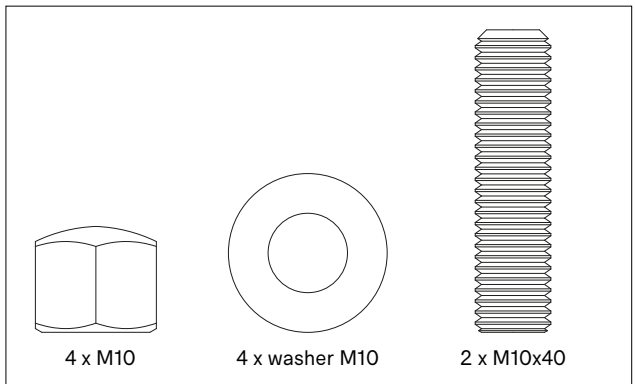

12.

Do this for both outer
A-frames

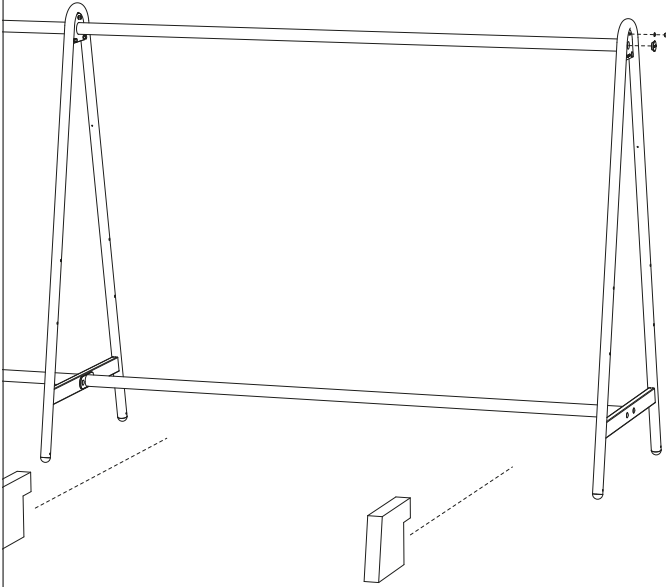
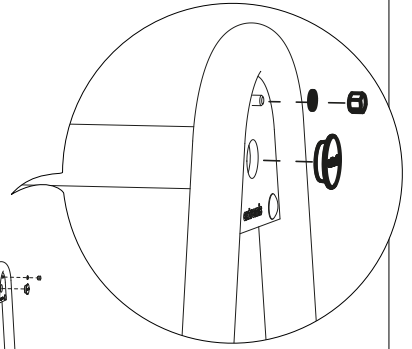

AMA285
per outer
A-frame

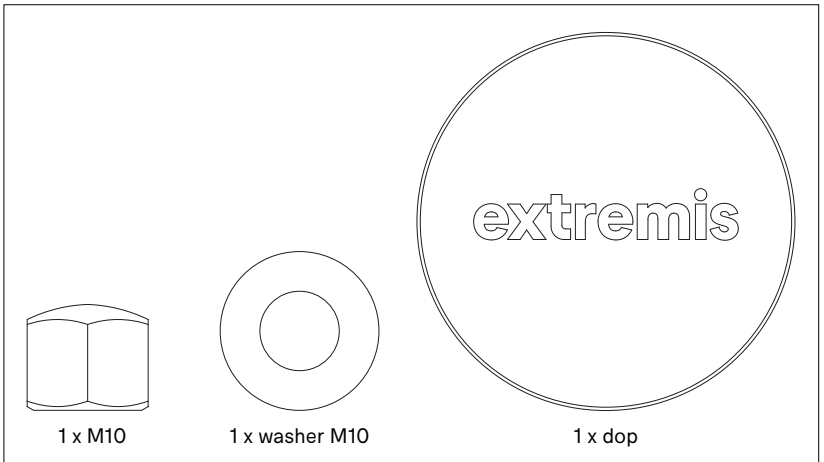

13.

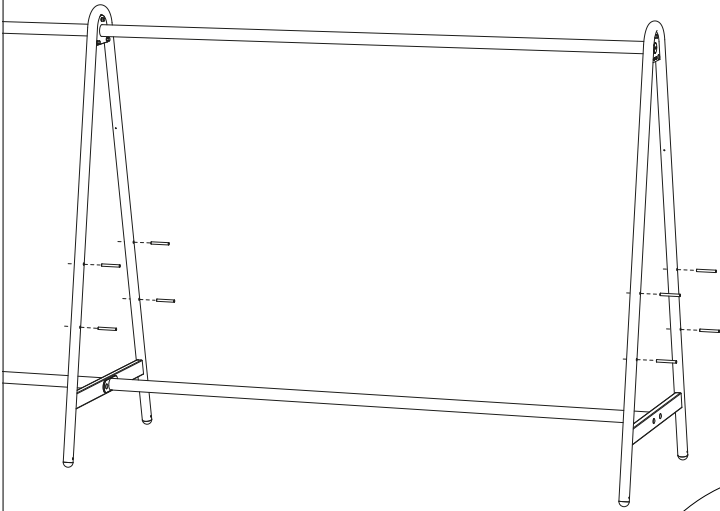

Do this for all A-frames

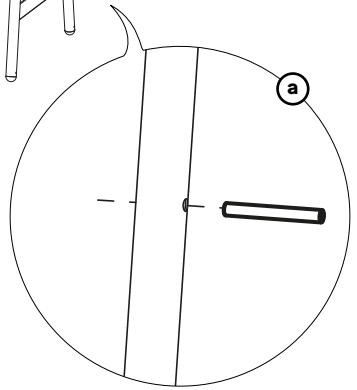
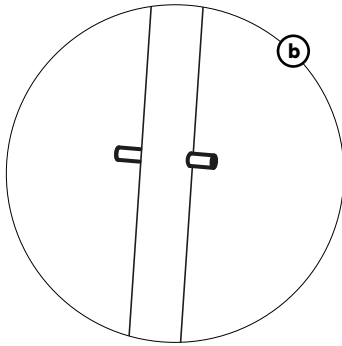

AMA201-1
per A-frame

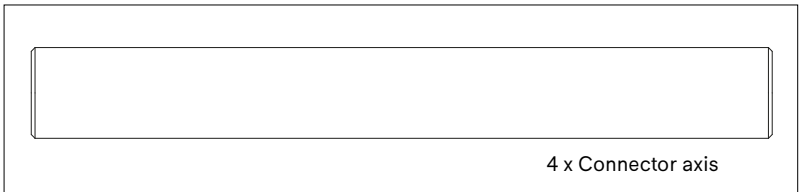

4 x Connector axis

14.

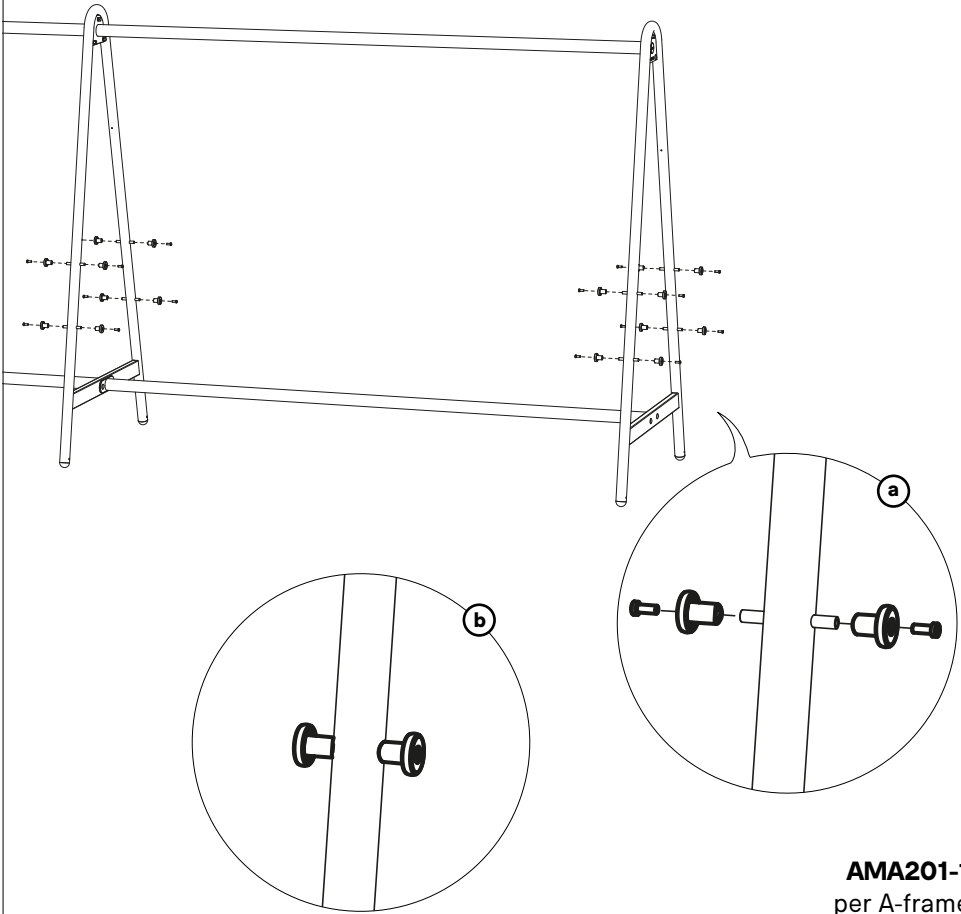

AMA201-1
per A-frame

Do this for all A-frames

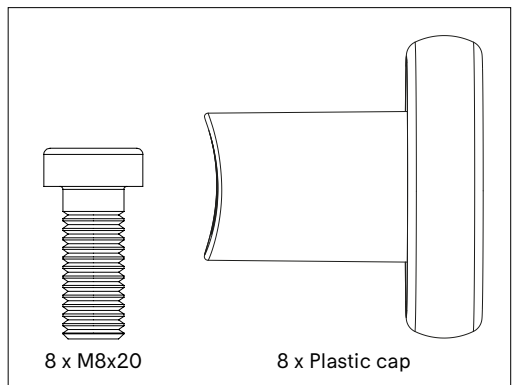

15.

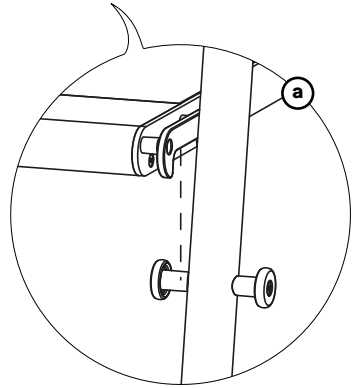
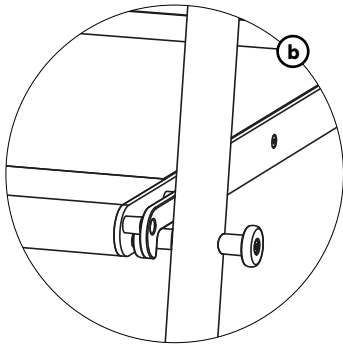
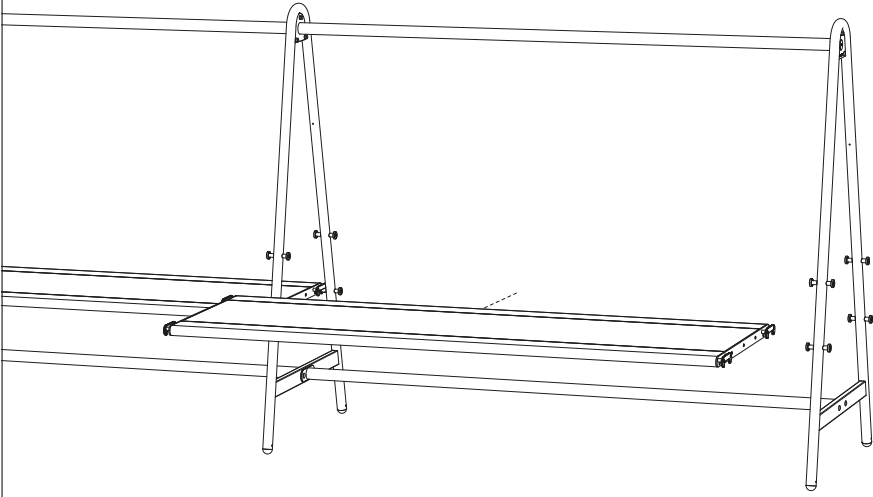

Add-on table

1.

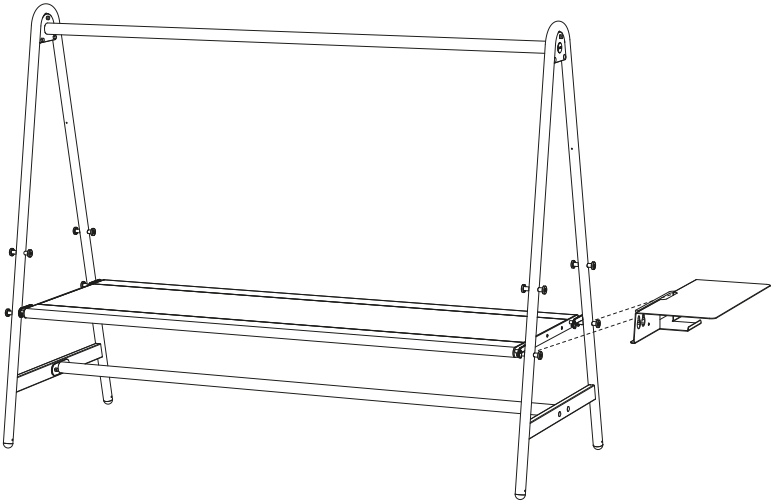

**Lowest position:
use outer holes**

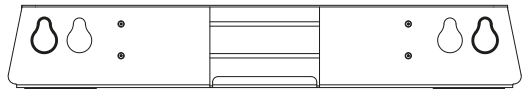
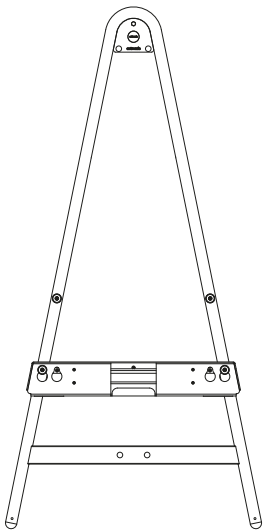

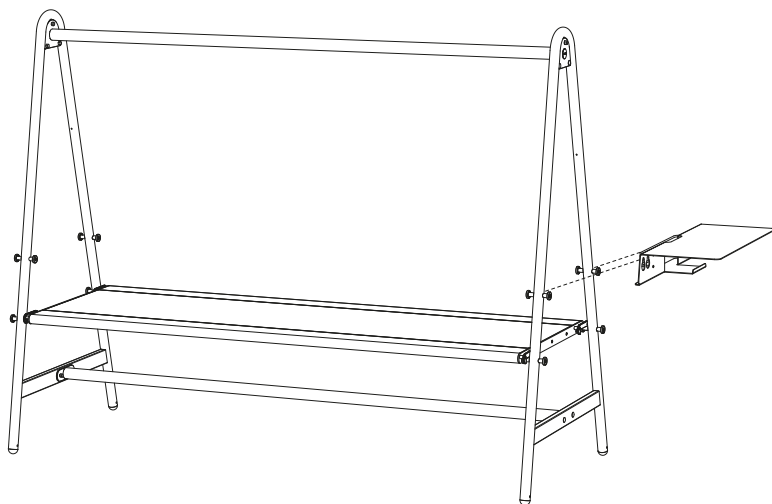

**Highest position:
use inner holes**

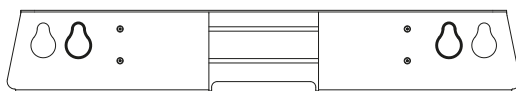
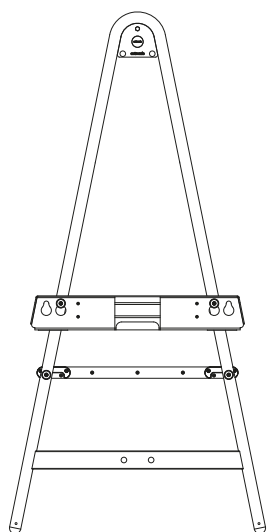

Screenholder

1.

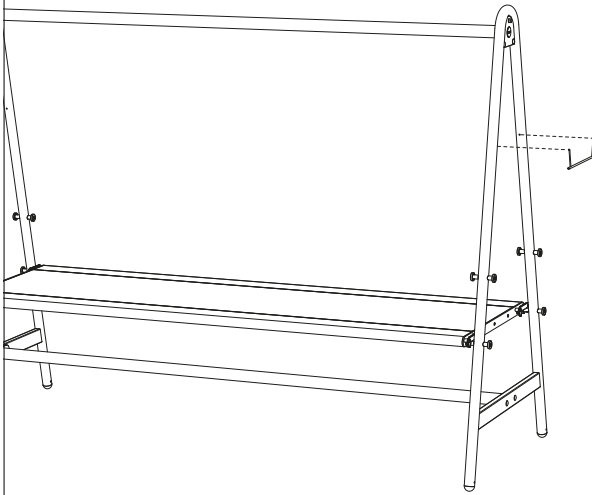

5'

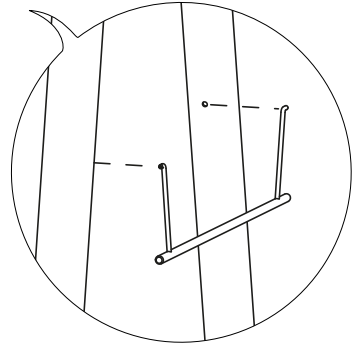

2.

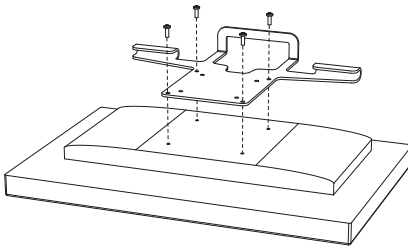

AMA435

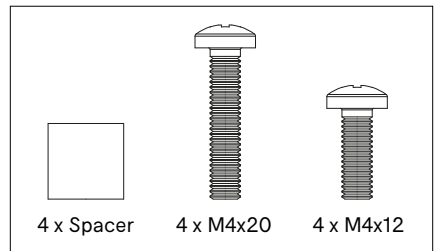

3.

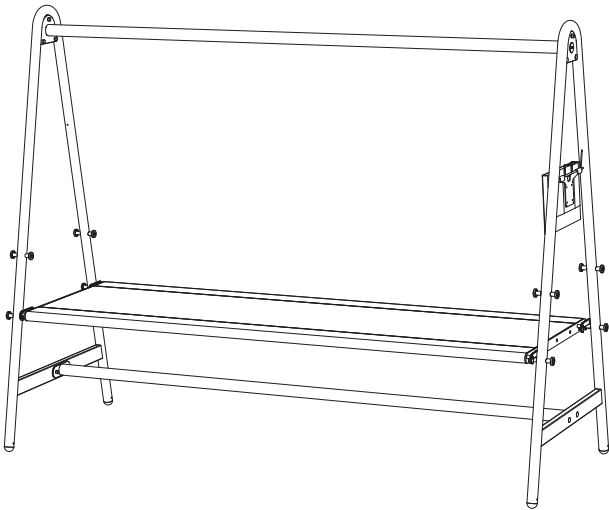
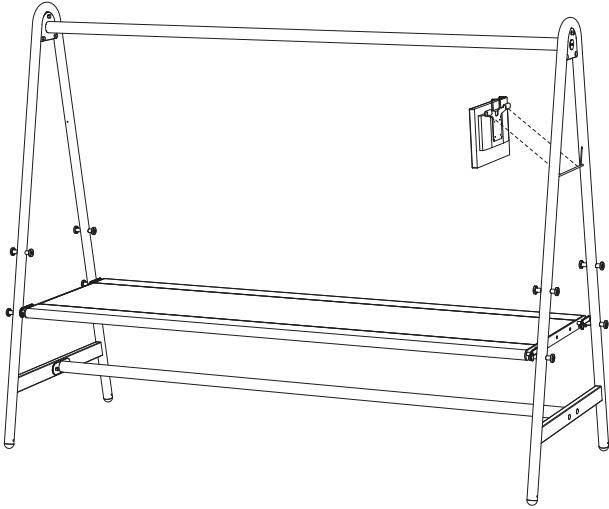

Tabletop fixation

1.

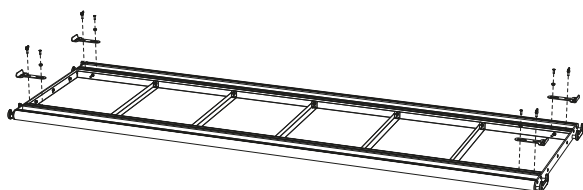

N° 5



N° 17



20'

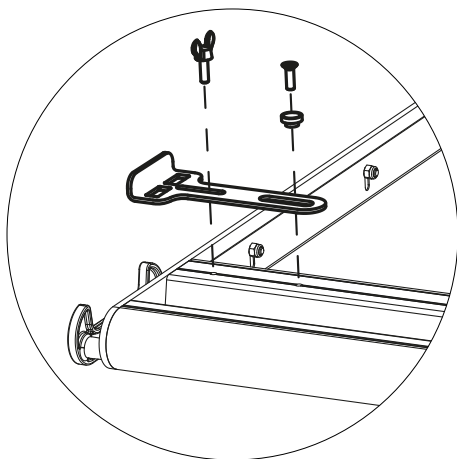

**Tighten the bolt with spacer.
Do not tighten the wing screw!**

AMA440

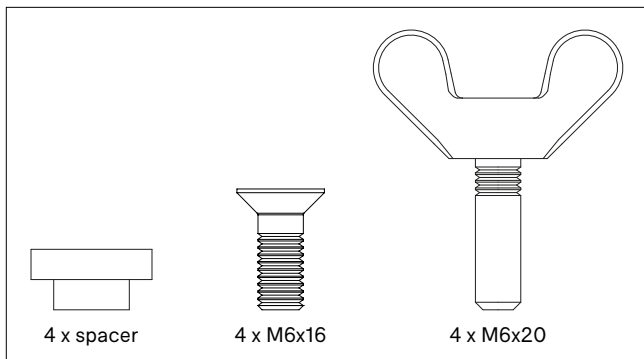

2.

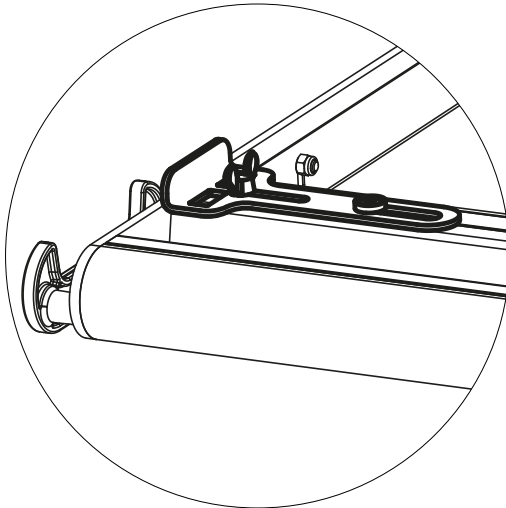
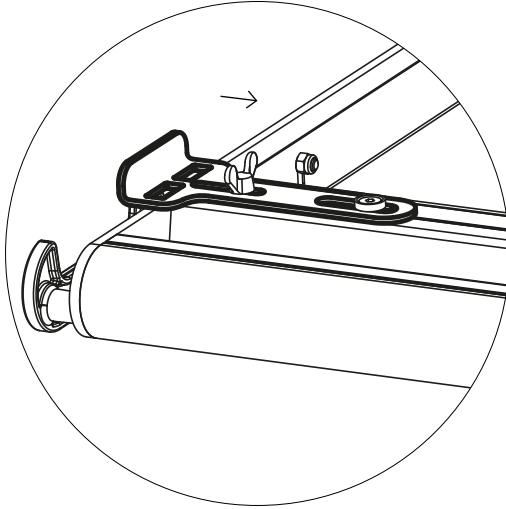

3.

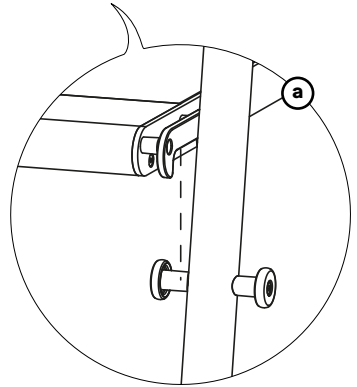
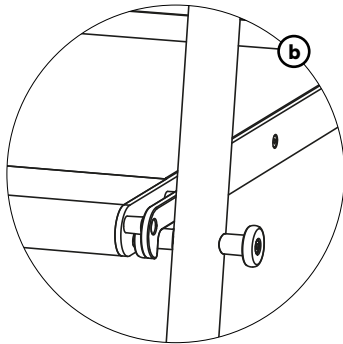
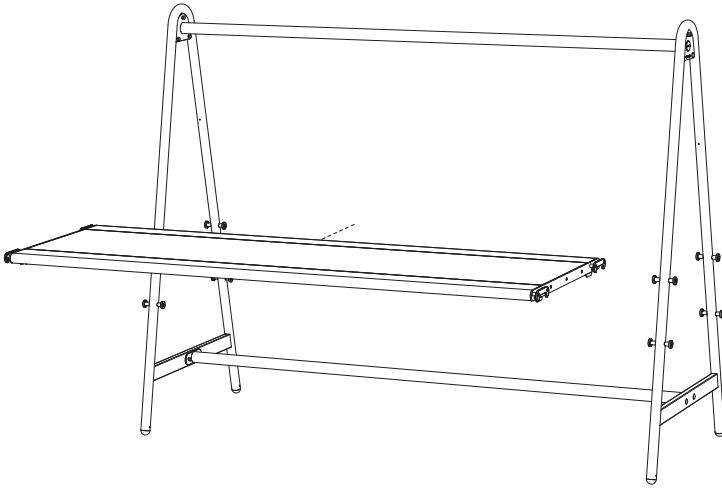

**Can only be combined when the tabletop
is in the highest position**

4.

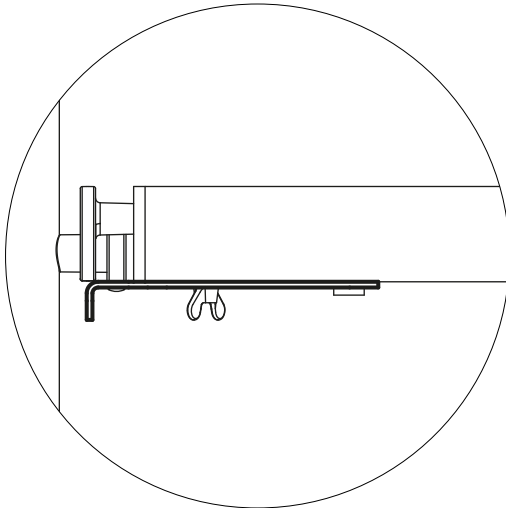
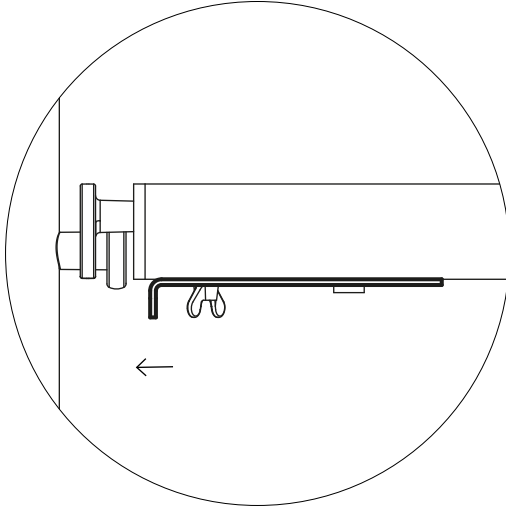

Tighten all wing screws

Leveling feet

1.

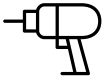
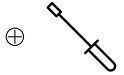
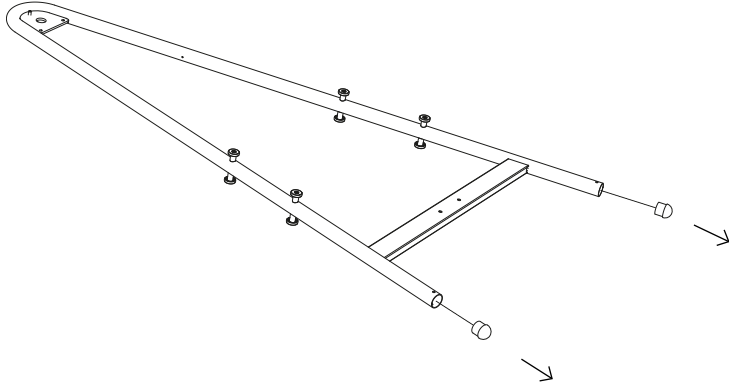

N° 17



10'

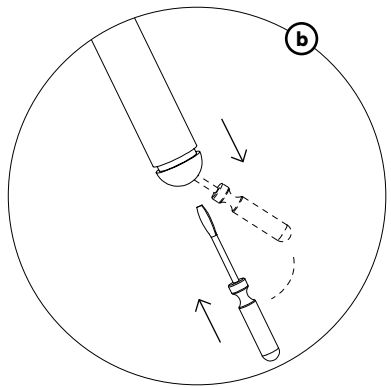
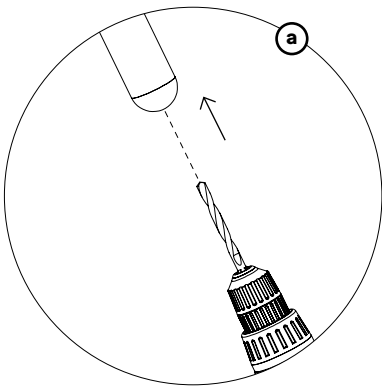

Remove the standard plastic caps

2.

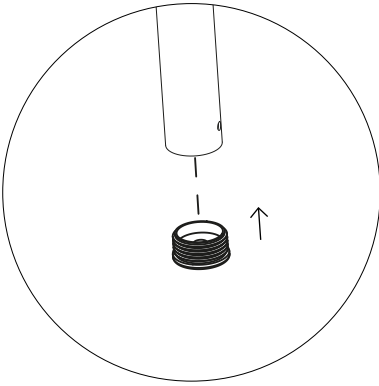

3.

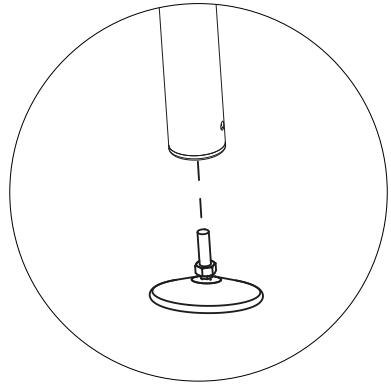

4a.

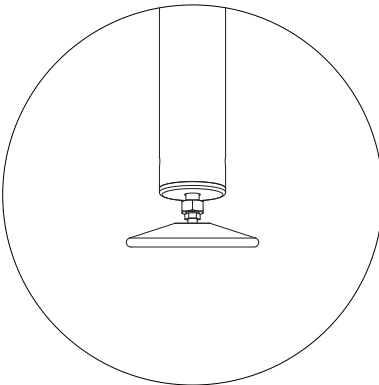

Level the feet until they touch the floor

4b.

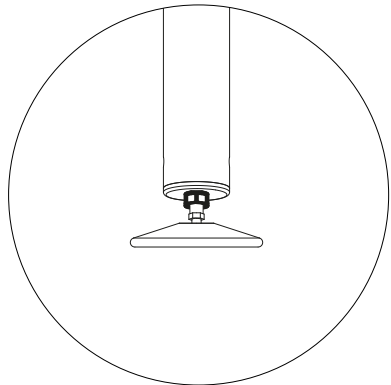

Fix the nut

Floor fastening

1.

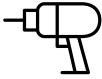
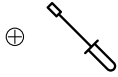
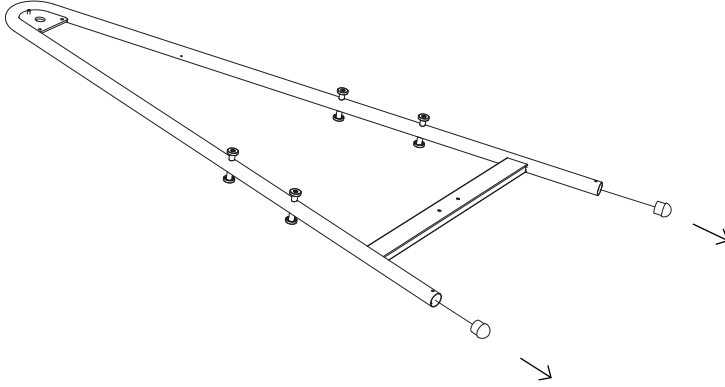

N° 13



10'

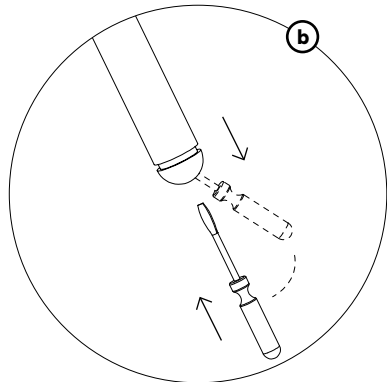
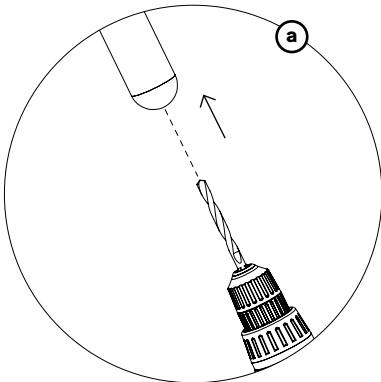

Remove the standard plastic caps

2.

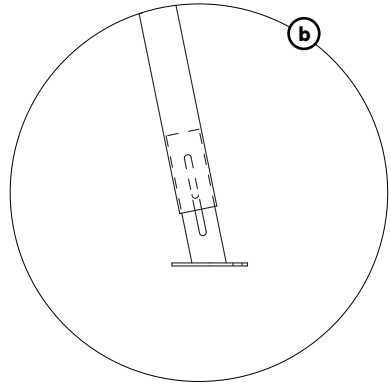
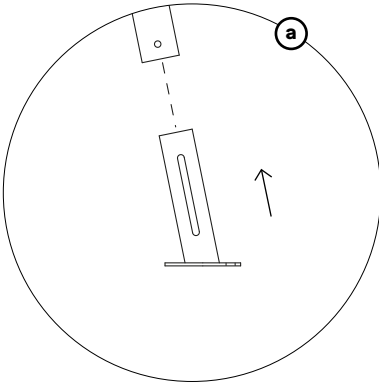

3.

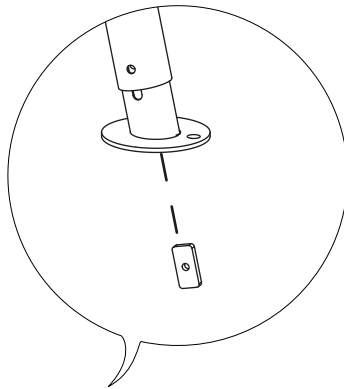
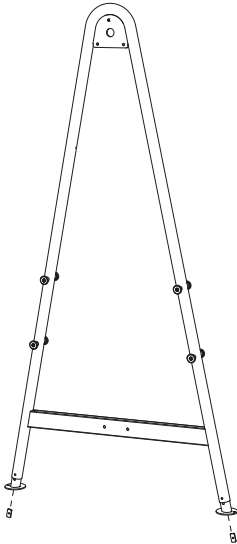

AMA442
per A-frame

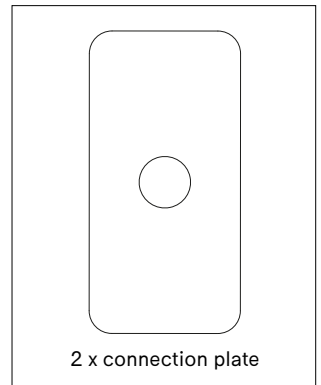

4.

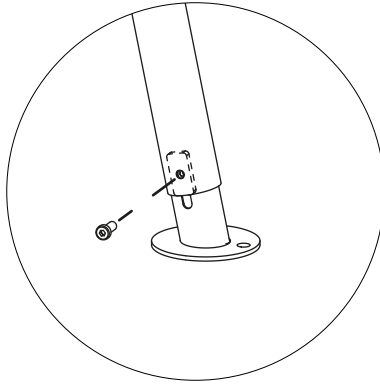

AMA442
per A-frame

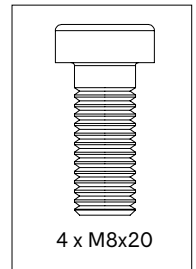

Do not tighten!

5.

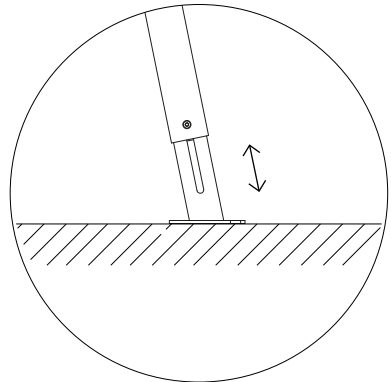
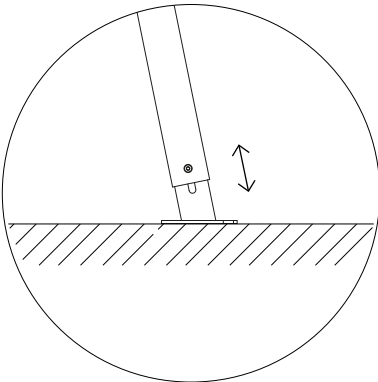

Put on the desired height & tighten the bolt

6.

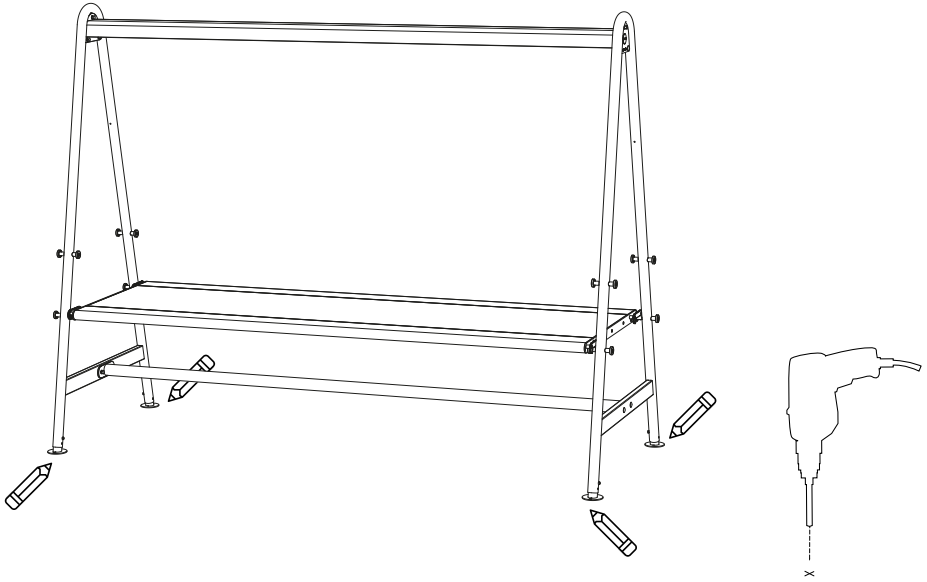

7.

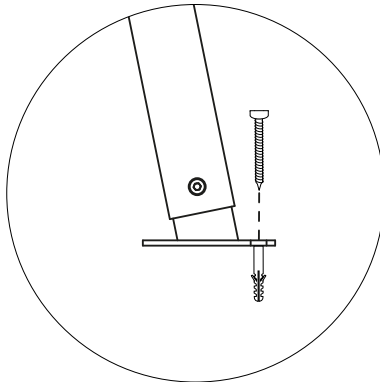

**Use the fasteners that are most
suitable for the surface**

Warnings

Text instructions

Maintenance

Warnings ↗

Assembly text instructions ↗

Maintenance ↗



Warnings

General

- Do not use any sharp tools to open the packaging.
- We strongly advise against using power tools.
- Tripping hazard, mind your step.
- Do not put out cigarettes on the bench.
- Not graffiti proof.
- Do not leave children unattended whilst playing on the bench.
- To avoid danger of suffocation, keep plastic bags away from babies and children.
- Colors can differ over years and from batch to batch.

Product

- Do not stand or jump on the table.
- Always make sure to hold the tabletop at its center when moving it up and down.
- Do not drag the table, but carry it with minimum 2 people.
- Anchoring the product has to be done by qualified people.
- For anchoring: use suitable bolts or screws from a specialized store depending on the material your terrace is made of.

Galvanized steel

- Galvanization will become less shiny when used outdoors.
- Flame retarding - NEN-EN13501-1 A1 - Class A1 products will not contribute to fire in any stage, including fully developed fire. For this reason, they are assumed to be capable of satisfying all requirements of all lower classes as well.
- Possible impurities in the immersion tank can cause black marks during galvanization, which are intrinsic to this industrial finishing technique.
- White marks on this zinc layer are also intrinsic to this procedure and



will disappear when the furniture is put outdoors.

- This industrial finishing technique may result in a rougher surface. This is intrinsic to the process.

Powder coating

- White powder coating requires more maintenance.
- Do not use abrasive scouring powders or scourers as they will scratch the surface.
- Color can fade to some extent when exposed to UV.
- Flame retarding - NEN-EN13501-1 A2-s1 - Satisfying the same criteria as Class B for the SBI-test according to EN13823. In addition, under conditions of a fully developed fire these products will not significantly contribute to the fire load and fire growth.
- Dark colors can get very hot in sunny weather.

Wood

- When delivered, the wood is untreated.
- Wood is a natural material and its look is different for every slat, plank and tree.
- Wood will gradually become rougher and start to turn grey as a consequence of exposure to the sun and rain. We recommend oiling the wood once or twice a year. 1x before the Summer and 1x after the Summer as protection for the Winter.
- Cleaning regularly with mild detergent. Never use a high pressure cleaner as this will roughen the wood's smooth surface and irreparably damage the wood's fibres.
- Thorough cleaning with Extremis Wood Cleaner.
- We strongly recommend that you treat your wood with wood oil to protect it from stains - Small cracks and crevices can also appear as part of this process. We strongly advise everyone to treat the furniture with our Wood Protector. It is best to repeat this treatment each year.

Soft desktop



- For indoor use only.
- Spilt liquids such as coffee, tea, alcohol, etc. must be removed immediately.
- Remove ink stains with turpentine or white spirit. Repair any dull spots that may emerge with a Forbo Polish and polish with a worn green scouring pad.

Oak veneer

- For indoor use only.
- Spilt liquids such as coffee, tea, alcohol, etc. and even water should be removed immediately.
- Do not use abrasive cleaning agents or aggressive solvents.
- Do not use wax polish.
- Light will affect the colour of the veneer.
- Temperature and humidity can cause the veneer to shrink or expand.
- Never place hot objects directly on the veneer.



Assembly text instructions



Take a look at the drawings, starting from page 11

Standard module (p11)

1. Open the boxes of the A-frames and take out the polystyrene blocks. Place two polystyrene blocks on the ground in the place where you want to assemble the AMAi. Make sure that the blocks are about 160 cm apart.
2. Place the footrest on the 2 polystyrene blocks.
3. **a.** Fit the first A-frame onto one end of the footrest, with the Extremis logo facing the outer side.
b. Assemble the A-frame using 2 M10x45 carriage bolts, 2 M10 cap nuts and spring washers. Now fit the second A-frame to the other end of the footrest, again with the Extremis logo facing the outer side, but do not fully tighten the bolts yet.
4. Now attach a set screw M10x35 in both A-frames as shown in the drawing. Make sure the set screw is centered to the A-frame.
5. Position the top tube between the two A-frames.
a. Slide the top tube over the adjusting screws so that it is correctly located.
b. First screw an M10 cap nut and spring washer onto the adjusting screw on both sides to hold the top tube in place.
6. Now attach the top tube on the two A-frames, each using two M10x25 carriage bolts, M10 cap nuts and washers. Now tighten all the bolts!
7. Screw an M10 cap nut and spring washer onto the outside of each of



the two adjusting screws, as well as a rubber cap with Extremis logo in the large holes as shown in the drawing.

8. Remove the expanded polystyrene blocks.
9. **a.** Insert the connector axis through the four holes on each A-frame.
b. Make sure they are properly centered.
10. Fit a black plastic cap onto each end of the pins and secure it with an M8x20 screw. Make sure that the plastic caps fit correctly on the A-frame and tighten all the screws.
11. You can now position the tabletop between the two A-frames on the preferred caps.

Extension module (p24)

1. Open the boxes of the A-frames and take out the polystyrene blocks. Place two polystyrene blocks on the ground in the place where you want to assemble the AMAi. Make sure that the blocks are about 160 cm apart.
2. Place the footrest on the 2 polystyrene blocks.
3. **a.** Fit the first A-frame onto one end of the footrest, with the Extremis logo facing the outer side.
b. Use 2 M10x45 carriage bolts, 2 M10 cap nuts and spring washers, but do not fully tighten the bolts yet.
4. Now attach the second A-frame to the other end of the footrest by inserting M10x50 carriage bolts through the holes in the footrest and the A-frame.
5. Now place two polystyrene blocks on the ground again and put the second footrest on top.
6. Slide the footrest over the two protruding carriage bolts on the A-frame and secure with 2 M10 cap nuts and spring washers, but do not fully tighten the bolts yet.
7. **a.** Now attach the third A-frame to the other end of the second footrest, with the Extremis logo facing the outer side.
b. Assemble the outer A-frame using 2 M10x45 carriage bolts, 2 M10 cap nuts and spring washers, but do not fully tighten the bolts yet.



8. Now attach a set screw M10x35 in the outer A-frames and one set screw M10x40 in the middle A-frame(s) as shown in the drawing. Make sure the set screw is centered to the A-frame.
9. Position the top tube between the two A-frames.
 - a. Slide the top tube over the adjusting screws so that it is correctly located.
 - b. First screw an M10 cap nut and spring washer onto the adjusting screw on both sides to hold the top tube in place.
10. Repeat the procedure for the second top tube.
11.
 - a. Now attach the top tube to the outer A-frames, each using two M10x25 carriage bolts, M10 cap nuts and washers. Tighten all bolts.
 - b. Also attach the top tube to the center frame(s), using two set screws M10x40, 4 M10 cap nuts and spring washers. Tighten all bolts.
12. Screw an M10 cap nut and spring washer onto the outside of each of the two adjusting screws, as well as a rubber cap with Extremis logo in the large holes as shown in the drawing. Remove the expanded polystyrene blocks.
13.
 - a. Insert the connector axis through the four holes on each A-frame.
 - b. Make sure they are properly centered.
14. Fit a black plastic cap onto each end of the pins and secure it with an M8x20 screw. Make sure that the plastic caps fit correctly on the A-frame and tighten all the screws.
15. You can now position the tabletop between the two A-frames on the preferred caps.

Add-on table (p40)

1. Hang the add-on table on the two black plastic caps on the A-frame where you want to use it. You can choose the desired height by using either the upper or lower pair of caps.

Screenholder (p42)

1. Fit the wire hanger to the desired A-frame by inserting it into the holes.



2. Fix the plate to the screen using the screws and spacers provided.
3. You can now hang the screen over the wire hanger.

Tabletop fixation (p44)

1. Place the tabletop upside down on a flat, clean surface and attach the two tabletop fixation plates to the two corners of the tabletop using one wing screw and one M6x16 countersunk screw with spacer on each. Make sure that the lip of the plate is on the outside and points away from the tabletop. Tighten the countersunk bolt firmly, but leave the wing screw loose so that the plate can still slide back and forth.
2. Slide the plates all the way in so that they do not protrude from the tabletop.
3. Turn the tabletop over and mount it in the highest position!
4. Slide the two plates outwards so that the two plastic caps of the A-frame sit properly in the recess of the plate and then tighten all the wing screws.

Leveling feet (p48)

1. Remove the standard plastic caps from the A-frames.
 - a. Drill a hole in the plastic cap.
 - b. Then pull out the plastic cap using a screwdriver as shown in the drawing.
2. Fit the new flat-ended caps with internal thread into the A-frames.
3. Screw the adjustable feet into these caps.
4.
 - a. Screw out the adjustable feet until they touch the ground everywhere.
 - b. Then fix them by tightening the nut.

Floor fastening (p50)

1. Remove the standard plastic caps from the A-frames.
 - a. Drill a hole in the plastic cap.



- b.** Then pull out the plastic cap using a screwdriver as shown in the drawing.
2. **a.** Now fit the stainless steel floor fastening feet into the A-frames.
b. Make sure that the disc at the bottom is kept parallel to the floor and that the hole lines up with the hole in the A-frame.
3. Now insert a connection plate inside the floor fastening foot.
4. Fix the bolts M8x20 through the hole of the A-frame and the floor fastening foot to the connection plate as shown in the drawing. Do not tighten the bolt!
5. Put your AMAi on the desired height & tighten all bolts on the floor fastening feet.
6. Mark the locations on the floor where the anchors are to be fitted and drill at the points indicated.
7. Use the fasteners that are most suitable for the surface on which the AMAi is to stand.



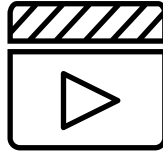

Watch the maintenance videos on our website:

www.extremis.com/maintenance

Galvanized steel

CLEANING

When dirty

Clean with lukewarm water and a brush.

REPARING DAMAGED PARTS WITH ZINC SPRAY

When damaged

Hot dip galvanization is the most durable way of protecting metal against rusting. If the zinc coating is damaged, the exposed metal can rust. This can easily be touched up with zinc paint that automatically has the same colour and is readily available in shops. Zinc spray forms a quick drying, self healing and flexible coating that helps stop corrosion.

Powder coating

CLEANING

Regularly

Use Extremis Multicleaner, a 100% biodegradable detergent or common kitchen cleaning products. Avoid using aggressive products. These surfaces are best cleaned with a neutral cleaning product diluted in water.



REPAIRING DAMAGED POWDER COATING

When damaged

The impact of sharp objects can damage the coating. Scratches or dents can be touched up with our paint pens. However this only camouflages the scratches without removing them.

Wood

DAY TO DAY CLEANING

Clean regularly and after every use

Wood doesn't need much maintenance, but the better you treat it, the longer it will last. Cleaning the wood regularly and immediately after use with a damp cloth will prevent fluids from penetrating deep into the wood. An oiled table will absorb liquids less quickly, keeping it clean for longer. To remove stubborn remains of dirt, simply use a stiff brush and some water. Be careful not to permanently damage the fibres. For this reason, never ever use a high-pressure cleaner to clean wood.

CLEANING

Once or twice a year

Depending on the weather conditions, wood needs a descent polish at least once a year. We would recommend to do this before Spring and before Winter, if your furniture is outside the whole year round. Pick one of those humid, cloudy days, as it is better for the moisture level in the wood to dry out slowly after cleaning. For a thorough cleaning, we can recommend our Extremis Wood Cleaner. This is a bio-degradable cleansing shampoo for wooden furniture. The product removes grey discolouration, green deposits and dirt. Should any cracks appear, you can simply sand them down by hand using 120 grit sandpaper.

OILING

Once a year

You are free to protect your wood from UV, inclement weather and



stains. Needless to say we strongly recommend to do this once a year. Extremis Wood Protector is a 100% natural product based on linseed oil. It is colorless, but the wood will be darker after this treatment. Remove all residues of old applications.

MACHINE SANDING

Only every 2 to 4 years

After a few years, there will be little cracks and maybe some warping in your wood. This is completely normal, because wood is a natural, living material. Solid wood has the great benefit that you can sand away the top layer to make the surface smooth and flat again. You can do this every two to four years with a hand-held sander. Do it on a dry day. Use 120-grit sandpaper for this.

REPLACING A WOODEN PART

Hey! You don't need to be an engineer to understand our products. And you don't even need to be great at DIY to replace a part. Do make sure that you can't repair the damage simply by sanding the slat.

Soft desktop

CLEANING

Regularly

Remove dust and fingerprints using a microfibre cloth. Remove small stains using a cleaning cloth and spray cleaner/indoor surface cleaner.

Clean badly soiled panels wet all over. Use a cleaning cloth and water containing indoor surface cleaner to wet the surface. Then dry with a well-rinsed and wrung-out cloth.

REMOVING STAINS

Only if nothing else helps

Remove stains as soon as they occur! Remove coffee, tea, alcohol imme-



diately before the substances begin to act on the table top. Take precautions by using coasters.

Oak veneer

CLEANING

Regularly

Dust regularly using a lightly dampened cloth in the direction of the wood grain, never across the grain. Wipe dry with a soft cloth immediately afterwards. Do not use too much water and, above all, do not leave any residual water. Do not use abrasive cleaning agents or aggressive solvents!

In case of spillage of soft drinks, beer, coffee, tea, wine, etc. and even water

Soak up the liquid immediately with a damp cloth and dry the area with a dry cloth or chamois leather. Use a soft cloth and particularly not paper towels. These can scratch the surface. Shrinkage or staining caused by moisture are therefore not covered by the guarantee.





Our headquarters:
Couthoflaan 20b
B-8972, Poperinge
info@extremis.com
+ 32 57 346020

extremis.com

Connect with us



All rights reserved. Unless otherwise specified, all designs and photographs contained in this publication are copyright protected and are the property of Extremis. No part of this publication may be copied or distributed without Extremis' prior written consent. The names of the authors of photographs to which we do not hold rights are mentioned here. We have done our utmost to provide a comprehensive list of names. In the event of an alleged breach, please contact the editorial staff. © Extremis

LAB149-1